

857-218-22-30 M39029/58-360 Type Size 22 Socket Contact with size 30 crimp barrel accommodation



HOW TO ORDER			
Sample Part No.	857-218	-22	-30
Product	857-218-22-30 = Socket Contact		
Contact Size	22		
Wire Size, AWG	30		

SPECIAL PURPOSE

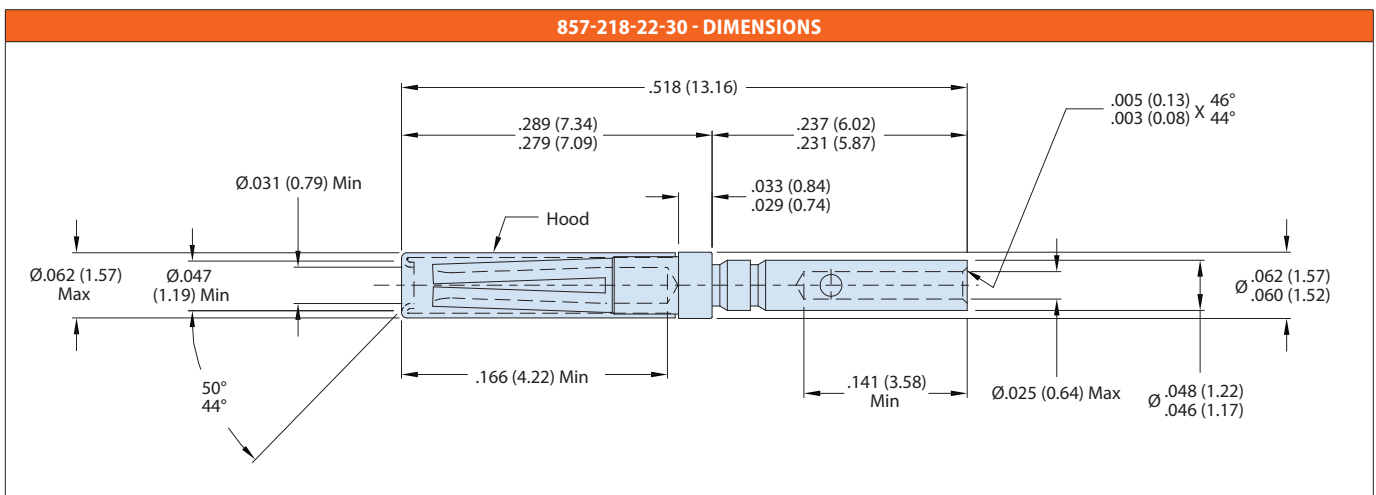

TABLE I - CRIMP TOOL SELECTOR			
Wire	26	28	30
Selector	5	4	3

MATERIAL / FINISH

- Contact body - copper alloy / gold plated per ASTM B 488, Type II, Code C, .000050 min thick over nickel per SAE AMS-QQ-N-290, Class 2, .000030 to .000150 thick.
- Hood - 305 CRES, passivated

NOTES

- Crimp tool data:
 - A) Crimp Frame - M22520/2-01 (Glenair p/n 809-015);
 - B) Positioner - M22520/2-09 (Glenair p/n 859-018)
 - C) Crimp tool selector: See Table I
 - D) Insertion/extraction tool - M81969/14-01 (Glenair p/n 859-020)
- Contact barrel accommodates 26 to 30 AWG