

# Series 66 Protective Covers

for MIL-DTL-83723 Series III Connectors

## 667-526, 667-528 ProSeal™ Flip Lid Receptacle Cover

**83723/III Receptacle Cover**

**ProSeal™ Flip-and-Spin Lid**



**ProSeal™ Flip Lid**



**Spring-loaded, waterproof.** ProSeal™ cover fits MIL-DTL-83723 Series III and EN2997 receptacle connectors. CCover mounts onto standard connector jam nut or square flange mounting holes. Two lid styles are available: *Flip Lid* and *Flip-and-Spin Lid*. Unthreaded flip lid has torsion spring and gimballed cover for dust-tight and water-tight sealing (IP67 rating). Flip-and-spin lid has threaded cover. Snap lid onto connector face, then hand-tighten ¼ turn for IP68 ingress protection plus IPX6 high pressure water spray. -40 to +120 °C.

**PART NUMBER**

			<b>667-526</b>	<b>C</b>	<b>18</b>	<b>T1</b>	<b>W</b>	<b>-59</b>	
<b>Base P/N</b>	<b>667-526</b>	<b>Flip-and-Spin Lid</b>							
		<i>M83723 Series III Threaded</i>							
	<b>667-528</b>	<b>Flip Lid</b>							
		<i>M83723 Series III Threaded and Bayonet</i>							
<b>Bracket Finish</b>	<b>C</b>	Black Anodize							
	<b>M</b>	Electroless Nickel							
	<b>MT</b>	Nickel-PTFE							
	<b>NF</b>	Cadmium, Olive Drab							
	<b>ZR</b>	Black Zinc-Nickel							
	<b>TZ</b>	Tin-Zinc							
<b>Shell Size</b>	<b>08</b>	<b>10</b>	<b>12</b>	<b>14</b>	<b>16</b>	<b>18</b>	<b>20</b>	<b>22</b>	<b>24</b>
<b>Panel Thickness</b>	<b>T0</b>	Front Mount ( <i>not applicable to jam nut mount</i> )							
	<b>T1</b>	.062 (1.6) +/- .030 (0.8)							
	<b>T2</b>	.125 (3.2) +/- .030 (0.8)							
<b>Mounting Type</b>	<b>J</b>	Jam Nut ( <i>fig. 1</i> )							
	<b>W</b>	Square Flange ( <i>fig. 2</i> )							
<b>Modification Code</b>	<i>Mod-59 is not available for P/N 667-526</i>								
	<b>-59</b>	Silver-Filled Silicone EMI Gasket							

**MATERIALS AND FINISHES**

Lid, lever arm, gimbal: thermoplastic, black  
 Bracket: aluminum, plated per finish code  
 Spring, pin, rivet: SST/passivate  
 Sleeve: Delrin  
 Gasket: silicone  
 Conductive gasket: silver-filled silicone

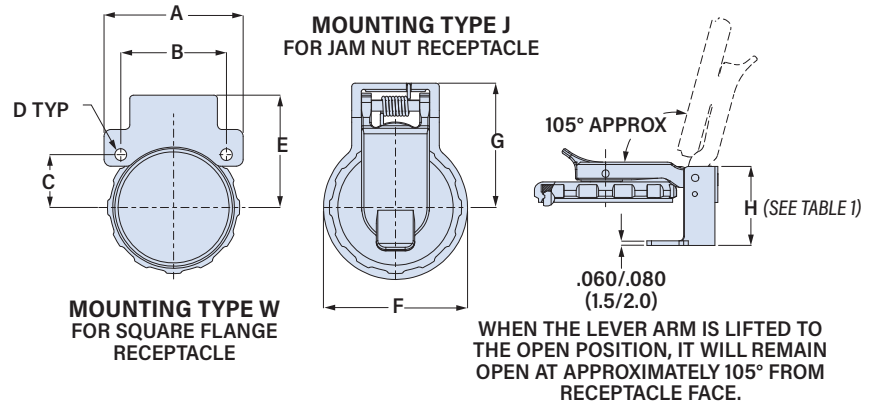
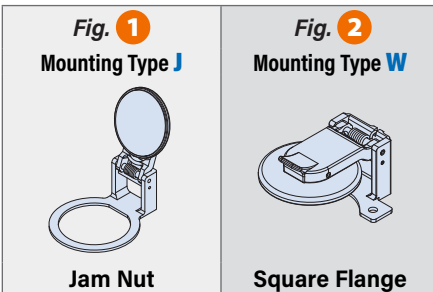

**TABLE 1 H DIMENSION**

Panel Thickness Code	Shell Size	H Max Bracket Height		Type J Jam Nut In.	Type W Square Flange In.	Shell Size	A Max		B		C		D		E Max		F		G Max	
		In.	mm.				In.	mm.	In.	mm.	In.	mm.	In.	mm.	In.	mm.	In.	mm.	In.	mm.
<b>T0</b>	Front Mount	08-18	N/A	N/A	.983	25.0														
		20-28	N/A	N/A	1.068	27.1														
<b>T1</b>	.062 ± .030 (1.6 ± 0.8)	08-18	.975	24.8	.921	23.4	1.062	27.0	.531	13.5	.120	3.0	1.149	29.2	1.625	41.3	1.149	29.2		
		20-28	1.060	26.9	1.006	25.6	1.156	29.4	.812	20.6	.406	10.3	1.031	26.2	1.299	33.0	.966	24.5		
<b>T2</b>	.125 ± .030 (3.2 ± 0.8)	08-18	.913	23.2	.859	21.8	1.250	31.8	.625	15.9	.120	3.0	1.429	36.3	2.000	50.8	1.429	36.3		
		20-28	.998	25.3	.944	24.0	1.375	34.9	.688	17.5	.147	3.7	1.491	37.9	2.150	54.6	1.491	37.9		
							1.562	39.7	.781	19.8	.147	3.7	1.708	43.4	2.500	63.5	1.678	42.6		