

Miscellaneous Accessories

Jam Nuts, Splice Rings, Dummy Contacts, Grommet Nuts, Bushings

809-035 Jam Nut, 687-207 Splice Ring

809-035 HEX JAM NUT FOR SERIES 80 MIGHTY MOUSE RECEPTACLES



809-035 jam nuts fit Series 80 Mighty Mouse receptacles. Available in aluminum or stainless steel, these jam nuts have optional safety wire holes. Add "W" to end of part number for safety wire holes.

TABLE 1 MATL/ FINISH

Aluminum	
M	Electroless Nickel
MT	Nickel-PTFE
NF	Olive Drab Cadmium
ZR	Black Zinc-Nickel
TZ	Tin-Zinc
Stainless Steel	
Z1	Passivate

A Thread	Part Number * = Material/Finish Code (Table 1)	B Hex		øC	
		± .015 (0.4) in	± .015 (0.4) mm	± .015 (0.4) in	± .015 (0.4) mm
.2500-32 UNEF-2B	809-035*01	.375	9.5	.403	10.2
.3125-28 UN-2B	809-035*02	.438	11.1	.475	12.1
.3125-32 UNEF-2B	809-035*03	.438	11.1	.475	12.1
.3750-28 UN-2B	809-035*04	.500	12.7	.547	13.9
.4375-28 UNEF-2B	809-035*05	.563	14.3	.620	15.7
.5000-32 UN-2B	809-035*23	.625	15.9	.690	17.5
.5625-24 UNEF-2B	809-035*06	.688	17.5	.755	19.2
.5625-28 UN-2B	809-035*16	.688	17.5	.755	19.2
.5625-32 UN-2B	809-035*07	.688	17.5	.755	19.2
.6250-20 UN-2B	809-035*24	.688	17.5	.755	19.2
.6250-28 UN-2B	809-035*08	.750	19.1	.830	21.1
.6875-28 UN-2B	809-035*09	.813	20.7	.898	22.8
.7500-28 UN-2B	809-035*10	.875	22.2	.970	24.6
.8125-28 UN-2B	809-035*17	.938	23.8	1.030	26.2
.8750-28 UN-2B	809-035*11	1.000	25.4	1.078	27.4
.9375-20 UNEF-2B	809-035*12	1.063	27.0	1.187	30.1
.9375-28 UN-2B	809-035*13	1.063	27.0	1.187	30.1
1.0000-28 UN-2B	809-035*18	1.125	28.6	1.200	30.5
1.0625-20 UN-2B	809-035*14	1.188	30.2	1.264	32.1
1.1250-28 UN-2B	809-035*15	1.250	31.8	1.325	33.7
1.1875-28 UN-2B	809-035*19	1.313	33.4	1.415	35.9
1.2500-28 UN-2B	809-035*20	1.375	34.9	1.490	37.8
1.3750-28 UN-2B	809-035*22	1.500	38.1	1.625	41.3
1.5000-28 UN-2B	809-035*21	1.625	41.3	1.750	44.5

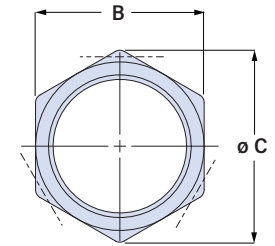
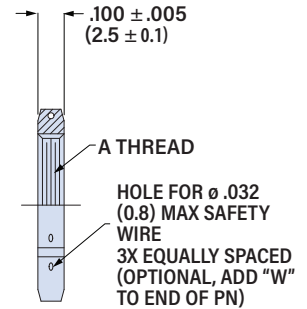

687-207 SPLICE RING



687-207 composite splice ring joins wire bundle shield braid with adapter braid sock. Splice ring consists of two identical snap-together halves. Install splice ring over wire bundle, then overlap braids and secure with Band-Master ATS® banding strap, purchased separately. Black thermoplastic.

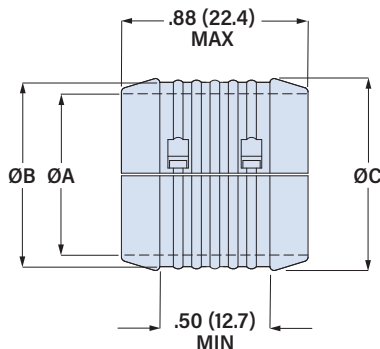

Splice Ring Part Number	øA		øB		øC		Band Part Number	
	± .03 (0.8) in	± .03 (0.8) mm	± .03 (0.8) in	± .03 (0.8) mm	± .03 (0.8) in	± .03 (0.8) mm	Flat	Pre-Coiled
687-207X004	.25	6.4	.36	9.1	.40	10.2	601-005	601-006
687-207X006	.38	9.7	.49	12.4	.53	13.5	601-005	601-006
687-207X008	.50	12.7	.61	15.5	.65	16.5	601-005	601-006
687-207X010	.63	16.0	.74	18.8	.78	19.8	601-005	601-006
687-207X012	.75	19.1	.86	21.8	.90	22.9	601-005	601-006
687-207X014	.88	22.4	.99	25.1	1.03	26.2	601-040	601-041
687-207X016	1.00	25.4	1.10	27.9	1.15	29.2	601-040	601-041
687-207X018	1.13	28.7	1.24	31.5	1.28	32.5	601-040	601-041
687-207X020	1.25	31.8	1.36	34.5	1.40	35.6	601-040	601-041
687-207X022	1.38	35.1	1.49	37.8	1.53	38.9	601-040	601-041
687-207X024	1.50	38.1	1.61	40.9	1.65	41.9	601-040	601-041
687-207X026	1.63	41.4	1.74	44.2	1.78	45.2	601-040	601-041
687-207X028	1.75	44.5	1.86	47.2	1.90	48.3	601-049	601-050
687-207X030	1.88	47.8	2.00	50.8	2.03	51.6	601-049	601-050
687-207X032	2.00	50.8	2.13	54.1	2.16	54.9	601-049	601-050