

871V007 • Style II

Al Alloy Swing-Arm Flex Clamp, Banding Adapter

FOR SERIES 806 MIL-AERO CONNECTORS



Adapter Code **V**

This accessory fits Glenair Series 806 Mil-Aero connectors

871V007 *Swing-Arm Flex Clamp* has aluminum coupling nut and body with high strength thermoplastic flex arms. Fits Glenair Series 806 Mil-Aeroconnectors. Style II accommodates larger cable entry sizes than standard Swing-Arm clamps. Adjustable arms pivot to 0°, 45° or 90° positions. includes EMI banding adapter with optional "T" slots for pigtailed individual shields. Terminate shield braid to adapter with optional Band-Master ATS® pre-coiled banding strap. Coupling nut has anti-decoupling mechanism for audible detented coupling and prevents backoff under high vibration.

PART NUMBER

		871V007	BM	16	S	J
Base P/N	871V007					
Finish Symbol	<i>See Table II</i>					
Shell Size	09 10 11 12 13 14 16 18 20 22 24					
Shield Termination Slot	<i>Omit if not required</i> S					
Precoiled Band Option	<i>Omit if not required</i> J Micro Slim band					

SWING-ARM FLEX CLAMPS

TABLE II
CLAMP BODY, COUPLING NUT,
SADDLES, DROP-IN BANDING
ADAPTER, THREAD BUSHING
MATERIAL / FINISH

Aluminum	
M	Electroless Nickel
NF	Cadmium Olive Drab Over Electroless Nickel
MT	Nickel-PTFE
TZ	Tin-Zinc
ZR	Zinc Nickel/Black Over Electroless Nickel, Matte Finish

871V007 • Style II Al Alloy Swing-Arm Flex Clamp, Banding Adapter

SWING-ARM FLEX CLAMPS

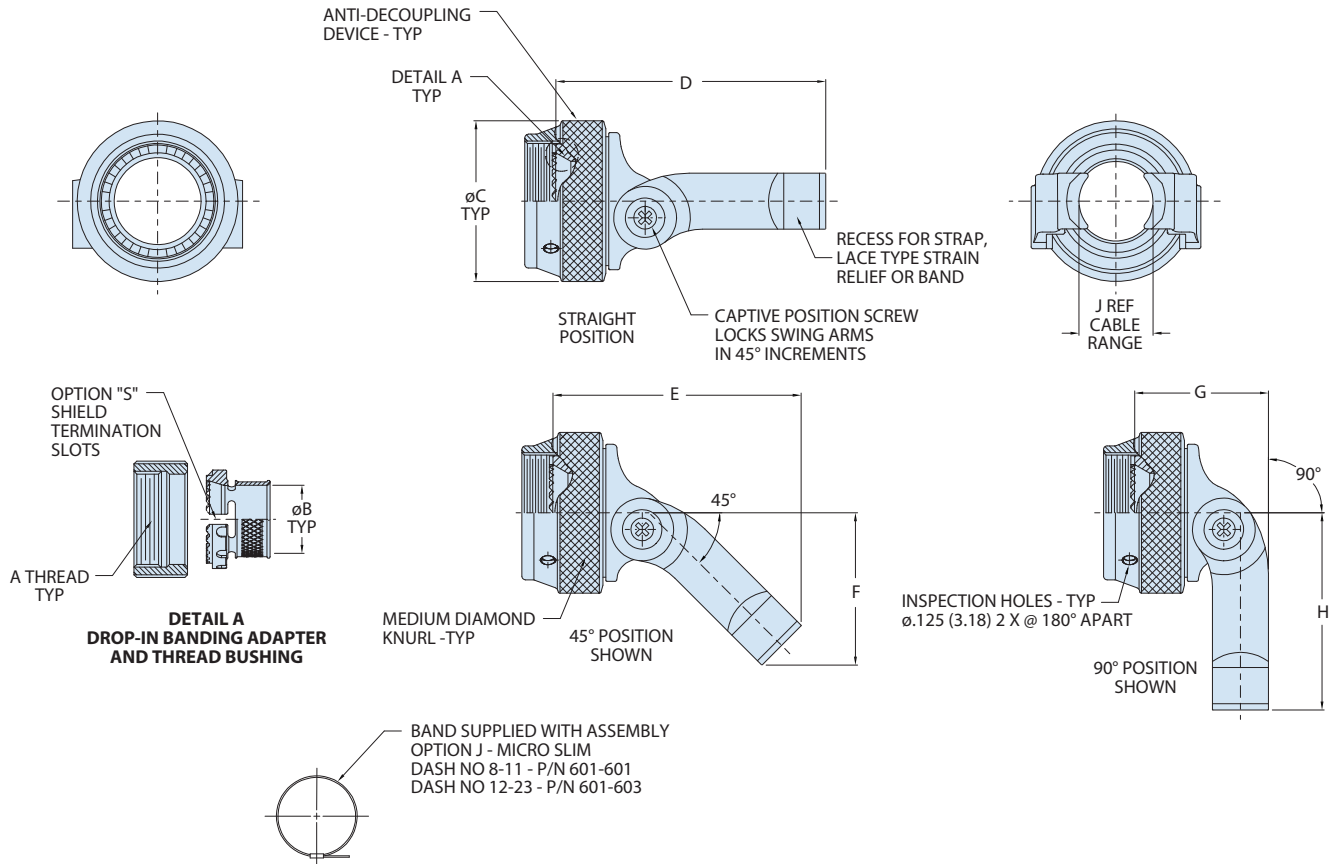

Shell Size	A Thread ISO Metric	ØB Min	ØC Max	D Max	E Max	F Max	G Max	H Max	J Ref Recommended Cable Range	
									Max	Min
09	M12 x 1.0-6H	0.305 (7.75)	0.938 (23.83)	1.90 (48.26)	1.67 (42.42)	0.89 (22.61)	1.06 (26.92)	1.15 (29.21)	0.455 (11.56)	0.121 (3.07)
10	M14 x 1.0-6H	0.404 (10.26)	1.125 (28.58)	2.18 (55.37)	1.98 (50.29)	1.10 (27.94)	1.15 (29.21)	1.44 (36.58)	0.598 (15.19)	0.157 (3.99)
11	M15 x 1.0-6H	0.404 (10.26)	1.125 (28.58)	2.18 (55.37)	1.98 (50.29)	1.10 (27.94)	1.15 (29.21)	1.44 (36.58)	0.598 (15.19)	0.157 (3.99)
12	M17 x 1.0-6H	0.526 (13.36)	1.250 (31.75)	2.18 (55.37)	1.98 (50.29)	1.16 (29.46)	1.15 (29.21)	1.50 (38.10)	0.710 (18.03)	0.210 (5.33)
14	M19 x 1.0-6H	0.565 (14.35)	1.250 (31.75)	2.18 (55.37)	1.98 (50.29)	1.16 (29.46)	1.15 (29.21)	1.50 (38.10)	0.710 (18.03)	0.210 (5.33)
16	M22 x 1.0-6H	0.658 (16.71)	1.375 (34.93)	2.39 (60.71)	2.23 (56.64)	1.28 (32.51)	1.31 (33.27)	1.68 (42.67)	0.839 (21.31)	0.246 (6.25)
18	M25 x 1.0-6H	0.777 (19.74)	1.500 (38.10)	2.39 (60.71)	2.23 (56.64)	1.35 (34.29)	1.31 (33.27)	1.81 (45.97)	0.934 (23.72)	0.277 (7.04)
20	M28 x 1.0-6H	0.877 (22.28)	1.625 (41.28)	2.85 (72.39)	2.64 (67.06)	1.63 (41.40)	1.47 (37.34)	2.12 (53.85)	1.068 (27.13)	0.313 (7.95)
22	M31 x 1.0-6H	0.999 (25.37)	1.750 (44.45)	2.85 (72.39)	2.64 (67.06)	1.67 (42.42)	1.47 (37.34)	2.16 (54.86)	1.197 (30.40)	0.349 (8.86)
24	M34 x 1.0-6H	1.127 (28.63)	1.875 (47.63)	3.06 (77.72)	2.85 (72.39)	1.84 (46.74)	1.56 (39.62)	2.41 (61.21)	1.323 (33.60)	0.380 (9.65)