

A

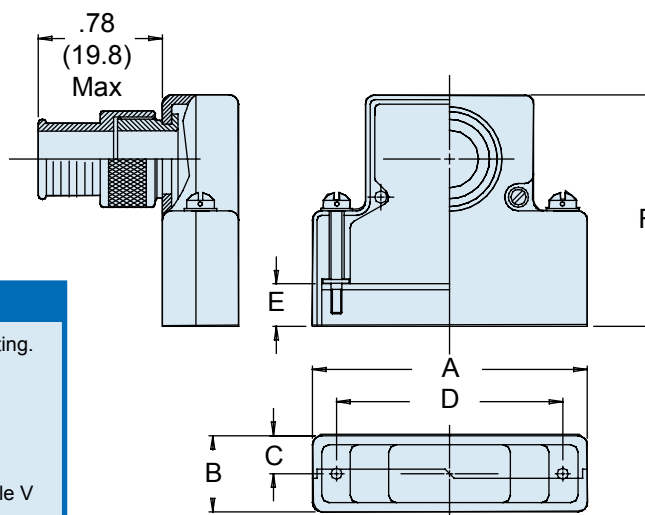
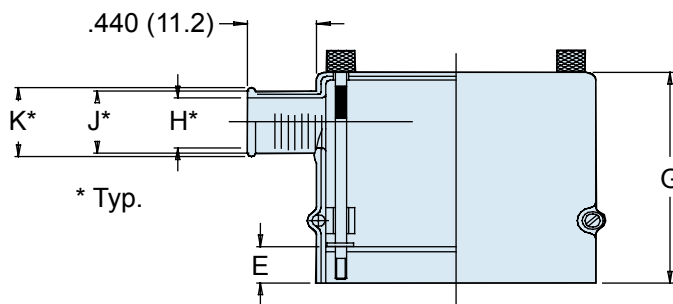
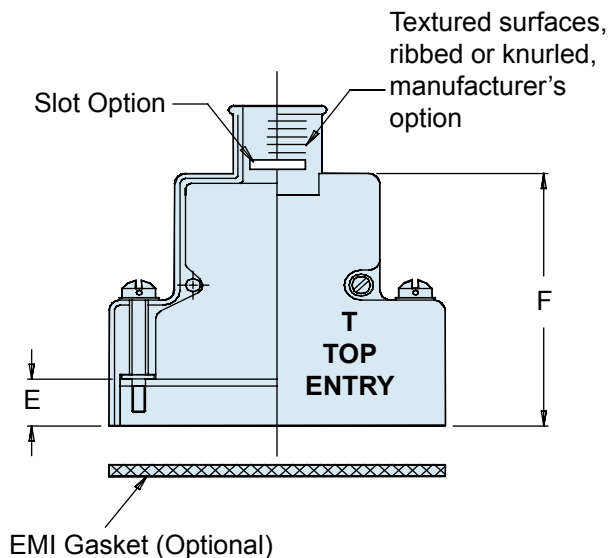
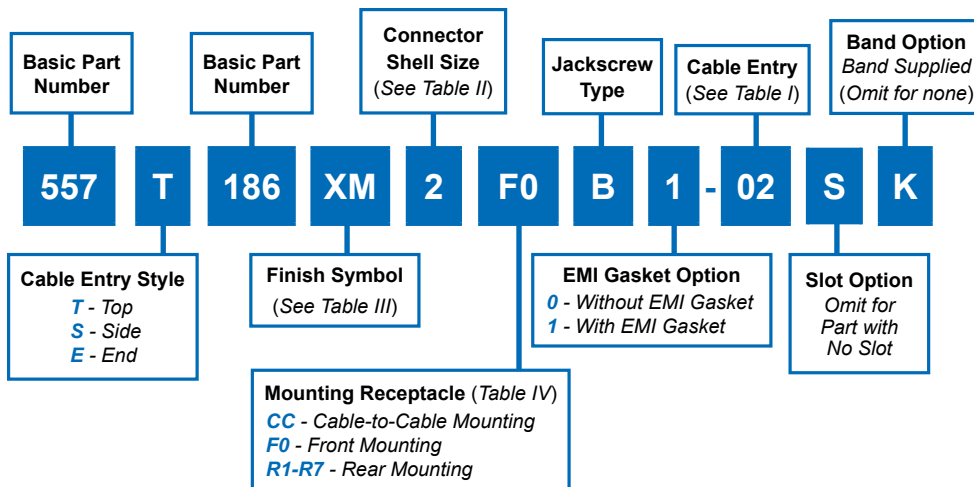

**APPLICATION NOTES**

1. Assembly identified with manufacturer's name and P/N, space permitting.
2. Maximum entry applicable to Style T and E, Shell Size 01.  
Entry S Max -04, Styles E & T Max -05.
3. Optional slot provided for strain relief, see Table I.
4. Material/Finish:  
Adapter, Backshell - High grade engineering thermoplastic, see Table V  
Hardware - Cres Passivate  
Gasket - Metex/N.A.  
Washer - Nylon/N.A.
5. Metric dimensions (mm) in parentheses.

**557-186**  
**Composite RFI/EMI Banding Backshell**  
**for MIL-DTL-24308 D-Subminiature Connectors**



Symbol	Finish Description
XM	2000 Hour Corrosion Resistant Electroless Nickel
XW	2000 Hour Corrosion Resistant Cadmium/Olive Drab over Electroless Nickel
XB	No Plating—Black Base Material Non-Conductive

Dash No.	H Dia	J Dia	K Dia	X
01	.125 (3.2)	.250 (6.4)	.312 (7.9)	N/A
02	.250 (6.4)	.375 (9.5)	.438 (11.1)	.062 (1.6)
03	.312 (7.9)	.438 (11.1)	.500 (12.7)	.094 (2.4)
04	.375 (9.5)	.500 (12.7)	.562 (14.3)	.156 (4.0)
05	.438 (11.1)	.562 (14.3)	.625 (15.9)	.188 (4.8)
06	.500 (12.7)	.625 (15.9)	.688 (17.5)	.219 (5.6)
07	.562 (14.3)	.688 (17.5)	.750 (19.1)	.250 (6.4)
08	.625 (15.9)	.750 (19.1)	.812 (20.6)	.250 (6.4)
09	.750 (19.1)	.875 (22.2)	.937 (23.8)	.312 (7.9)
10	.875 (22.2)	1.000 (25.4)	1.062 (27.0)	.375 (9.5)
11	1.000 (25.4)	1.125 (28.6)	1.188 (30.2)	.375 (9.5)

Shell Size	A	B Max	C	D ±.005 (.1)	E	F	G	Max Entry (See Note 2)
1	1.378 (35.0)	.624 (15.8)	.312 (7.9)	.984 (25.0)	.340 (8.6)	1.625 (41.3)	1.750 (44.5)	04/05
2	1.691 (43.0)	.624 (15.8)	.312 (7.9)	1.312 (33.3)	.340 (8.6)	1.625 (41.3)	1.750 (44.5)	05
3	2.250 (57.2)	.624 (15.8)	.312 (7.9)	1.852 (47.0)	.343 (8.7)	1.844 (46.8)	2.000 (50.8)	05
4	2.879 (73.1)	.624 (15.8)	.312 (7.9)	2.500 (63.5)	.343 (8.7)	1.844 (46.8)	2.000 (50.8)	05
5	2.785 (70.7)	.735 (18.7)	.375 (9.5)	2.406 (61.1)	.343 (8.7)	1.844 (46.8)	2.000 (50.8)	07

Dash No.	Panel Thickness	E	F		G	
			Sizes 1 & 2	Sizes 3 - 5	Sizes 1 & 2	Sizes 3 - 5
R1	.031 (.8)	.247 (6.3)	1.525 (38.7)	1.745 (44.3)	1.656 (42.1)	1.904 (48.4)
R2	.047 (1.2)	.231 (5.9)	1.509 (38.3)	1.728 (43.9)	1.640 (41.7)	1.888 (48.0)
R3	.062 (1.6)	.216 (5.5)	1.500 (38.1)	1.720 (43.7)	1.625 (41.3)	1.873 (47.6)
R4	.093 (2.4)	.185 (4.7)	1.470 (37.3)	1.690 (42.9)	1.594 (40.5)	1.842 (46.8)
R5	.104 (2.6)	.174 (4.4)	1.451 (36.9)	1.671 (42.4)	1.583 (40.2)	1.831 (46.5)
R6	.125 (3.2)	.153 (3.9)	1.430 (36.3)	1.650 (41.9)	1.563 (39.7)	1.811 (46.0)
R7	.156 (4.0)	.125 (3.2)	1.400 (35.6)	1.620 (41.1)	1.532 (38.9)	1.780 (45.2)

Shell Size	A	B Max	C	D ±.005 (0.1)	F	E +.030 (0.8)-.000	Max Entry (See Note 2)
1	1.363 (34.6)	.624 (15.8)	.322 (8.2)	.984 (25.0)	1.455 (37.0)	.170 (4.3)	05
2	1.691 (43.0)	.624 (15.8)	.322 (8.2)	1.312 (33.3)	1.455 (37.0)	.170 (4.3)	05
3	2.250 (57.2)	.624 (15.8)	.322 (8.2)	1.852 (47.0)	1.673 (42.5)	.172 (4.4)	05
4	2.879 (73.1)	.624 (15.8)	.322 (8.2)	2.500 (63.5)	1.673 (42.5)	.172 (4.4)	05
5	2.785 (70.7)	.735 (18.7)	.375 (9.5)	2.406 (61.1)	1.673 (42.5)	.172 (4.4)	07