

712S269 Composite Shrink Boot Conduit Fitting For Glenair Series 74 Helical Convuluted Tubing

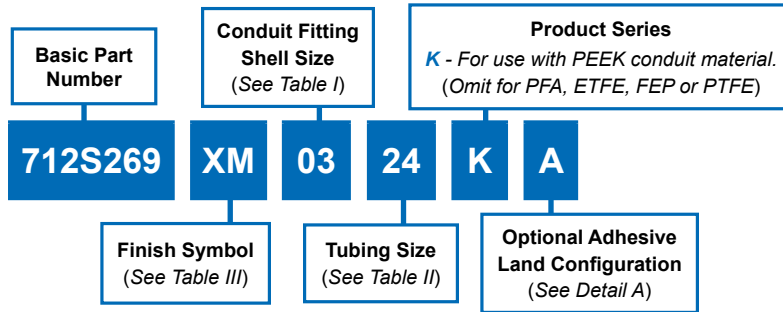

DETAIL A
Optional Adhesive Land Configuration
(See Part Number)

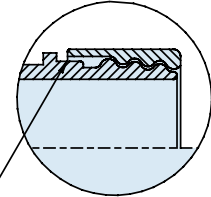

Land area to accommodate adhesive

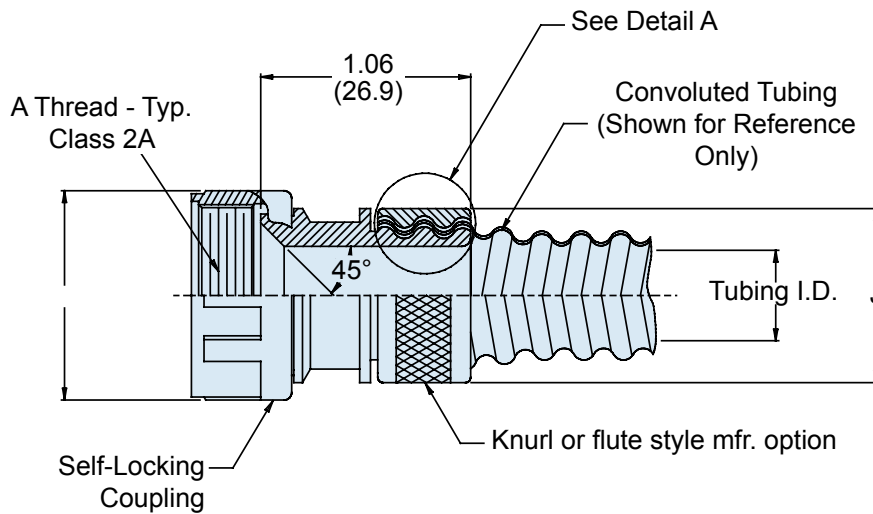

TABLE III	
Symbol	Finish Description
XB	No Plating - Black Color (Non-Conductive Finish)
XM	2000 Hour Corrosion Resistant Electroless Nickel
XMT	2000 Hour Corrosion Resistant Ni-PTFE, Nickel-Fluorocarbon Polymer. 1000 Hour Grey™
XO	No Plating - Brown Color (Non-Conductive Finish)
XW	2000 Hour Corrosion Resistant Cadmium/Olive Drab over Electroless Nickel

TABLE II: TUBING SIZE

Tubing Size	Conduit I.D.	J Dia Max
06	.188 (4.8)	.790 (20.1)
09	.281 (7.1)	.985 (25.0)
10	.312 (7.9)	.985 (25.0)
12	.375 (9.5)	1.035 (26.3)
14	.437 (11.1)	1.100 (27.9)
16	.500 (12.7)	1.160 (29.5)
20	.625 (15.9)	1.285 (32.6)
24	.750 (19.1)	1.480 (37.6)
28	.875 (22.2)	1.670 (42.4)
32	1.000 (25.4)	1.720 (43.7)
40	1.250 (31.8)	2.100 (53.3)
48	1.500 (38.1)	2.420 (61.5)
56	1.750 (44.5)	2.660 (67.6)
64	2.000 (50.8)	2.910 (73.9)

TABLE I: CONDUIT FITTING SHELL SIZE

Shell Size	A Thread Unified	Max Conduit Size Table 2	Weight in Pounds Max.
01	.750 - 20	16	.032
02	1.000 - 20	24	.043
03	1.312 - 18	32	.057
04	1.500 - 18	40	.070
05	2.000 - 18	64	.094
06	.500 - 20	09	.030
07	.625 - 24	12	.031

APPLICATION NOTES

1. Metric dimensions (mm) are in parentheses and are for reference only.
2. Convuluted tubing to be ordered separately. See Type A.
3. Mates to 710-318, -319, -320 and -321 transitions
4. Coupling nut supplied unplated.
5. For permanent termination use 3M Scotch Weld after installing tubing. See detail A.