

601-205 Calibration Key and 601-211 Standard and 601-212 Micro Banding Tool Tension Gauges

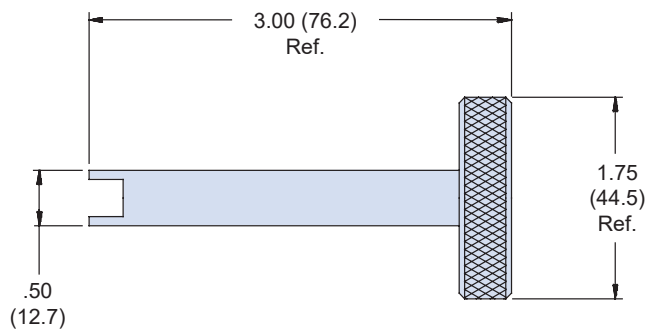

601-205 Calibration Key (Replaces 600-055)

The **601-205 Calibration Key** is designed for use with 600-058, 600-061, 601-211 and 601-212 manual banding tools. Material is black anodized aluminum alloy. One full turn clockwise will advance the tension range approximately 1.0 - 2.5 lbs, a counter-clockwise turn will decrease tension by the same amount.

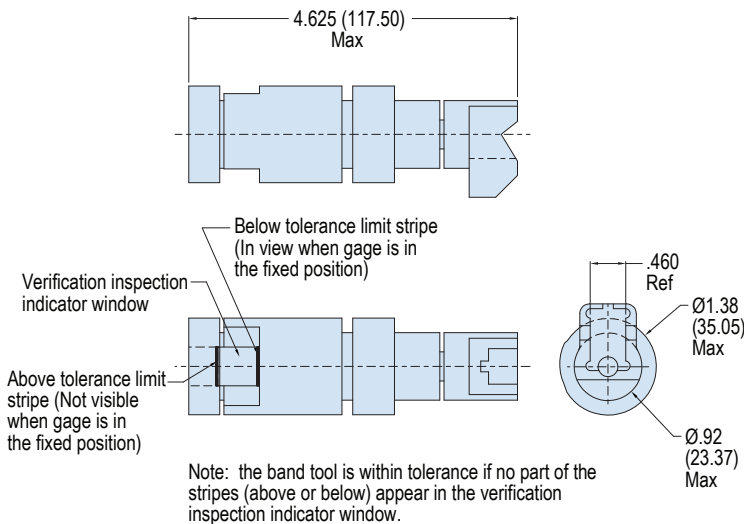

601-211 Tension Gauge (Replaces 600-072-1)

The **601-211 (M81306/1C) Tension Gauge** is used to check and calibrate the manual tool to values noted on calibration sticker. Constructed of hardened steel.

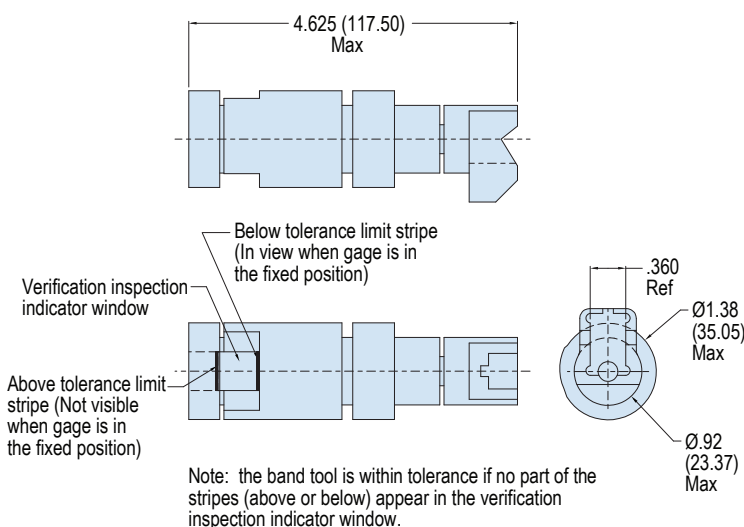

601-212 Tension Gauge (Replaces 600-086-1)

The **601-212 (M81306/1D) Tension Gauge** is used to check and calibrate the manual tool to values noted on calibration sticker. Constructed of hardened steel.



Metric Dimensions (mm) are indicated in parentheses.