

SUPERNINE MIL-DTL-38999 SERIES III TYPE ARINC 801 Optical Termini and Connectors

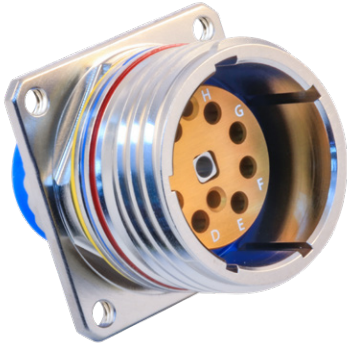

180-159 Wall Mount, (T7) Threaded Insert Holes (CM) Metric Clinch Nuts

ARINC 801



Tight-tolerance MIL-DTL-38999 Series III type Wall Mount Receptacles, Threaded Holes or Metric Clinch Nuts. Compatible with Size 16 snap-in, rear-release ARINC 801 genderless termini (Glenair series 181-076). Precision-machined insert ensures optimum optical fiber alignment and low dB data loss performance. Triple-start stub ACME threads for fast mating and robust anti-decoupling. The ARINC 801 fiber optic system leverages D38999 mechanical and environmental design elements including mating interface, accessory attachment interface, ratcheting coupling nut, polarization keyways, O-ring seals, panel cutouts, and more. Connector shell materials include aluminum alloy, composite thermoplastic, stainless steel, and marine bronze. Keyed polarization for mis-mate protection. Available insert arrangements support from two to 32 singlemode and multimode termini.

MATERIAL/FINISH NOTES

- Inserts for composite connector:
Composite or Al Alloy – MFR's Option
- Seals: Fluorosilicone
- Hardware:
Stainless steel / passivate

HOW TO ORDER

Sample Part Number	180-159	NF	T7	-17-8	N
Fiber Optic connector	ARINC 801, MIL-DTL-38999 Series III Type				
Material/Finish Code	See Material and Finish table				
Connector Style, Receptacles	T7 = Wall Mount Receptacle with Threaded Holes CM = Wall Mount Receptacle with Metric Clinch Nuts				
Shell Size - Insert Arrangement	See Shell Size / Contact Arrangements table				
Alternate Key Position	per MIL-DTL-38999 Series III. A, B, C, D, E, N = Normal, omit for universal key				

SHELL SIZE / CONTACT ARRANGEMENTS (FACE OF RECEPTACLE INSERT)

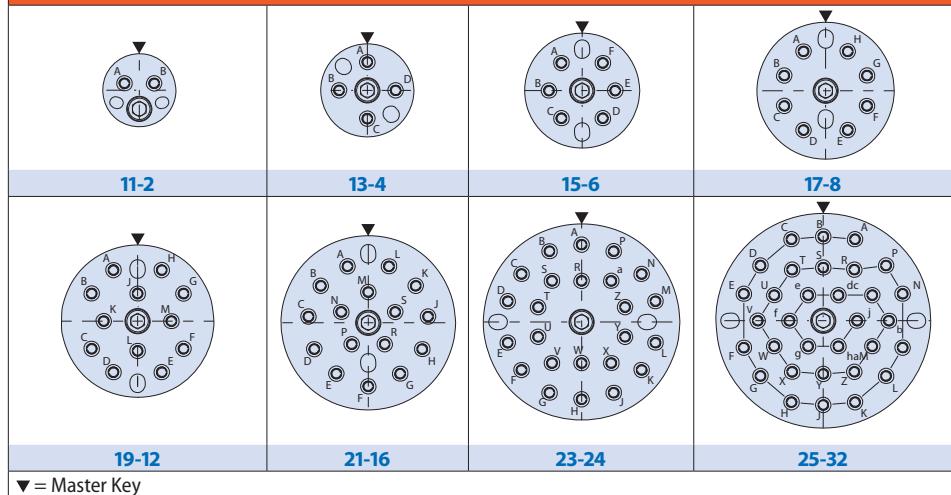

MATERIAL AND FINISH

Code	Material	Finish Description
ME	Aluminum	Electroless Nickel
MT		Nickel-PTFE, Gray
NF		Cadmium, Olive Drab
TZ		Tin-Zinc, Bronze-Gold
ZN		Zinc-Nickel, Olive Drab
ZR	Zinc-Nickel, Black (RoHS)	
XM	Composite	Electroless Nickel
XMT		Nickel - PTFE, Grey
XW		Cadmium, Olive Drab
XZN		Zinc-Nickel, Black
MS	Stainless Steel	Electroless Nickel
ZL		Electro-Deposited Nickel
ZI		Passivate
AB	Marine Bronze	De-Grease / No Plating

NOTES

- Universal connectors are intended for use in testing facilities only and should be highly evaluated before consideration in another environment.
- Receptacle connector with universal key polarization contains all key way polarizations (A, B, C, D, E, N) which may have overlap in adjacent minor key ways.
- Plug connector with universal polarization contains master key only.
- Blue color band indicates rear release retention system.
- For dummy terminus, see Glenair 181-128.
- Insert/extraction tool: 809-131 (M81969/14-03).

SUPERNINE MIL-DTL-38999 SERIES III TYPE ARINC 801 Optical Termini and Connectors



180-159 Wall Mount, (T7) Threaded Insert Holes (CM) Metric Clinch Nuts

ARINC 801

WALL MOUNT WITH THREADED HOLES - DIMENSIONS

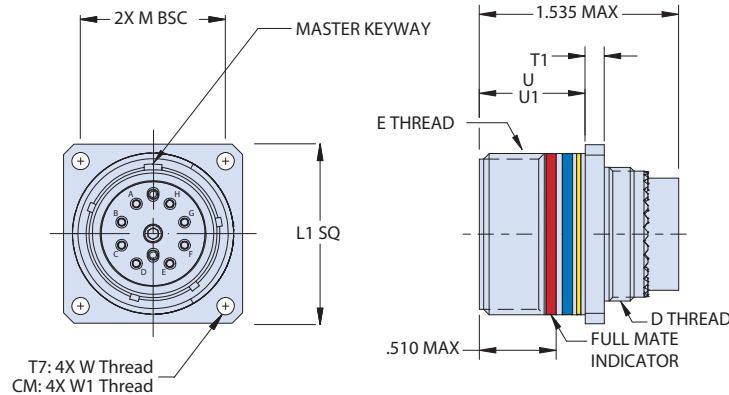

Shell Code	Shell Size	E Thread	L1 SQ	M Bsc	T1	U	U1 (Composite)	D Thread	W Threaded Insert	W1 Clinch Nut
B	11	.7500-1P-.3L-TS-2A	1.132 (28.75) 1.092 (27.74)	.812 (20.62)	.144 (3.66) .083 (2.11)	.820 (20.83) .771 (19.58)	.823 (20.90) .768 (19.51)	M15 X 1.0-6g 0.100R	.112-40 UNC-2B	M3 X 0.5
C	13	.8750-1P-.3L-TS-2A	1.226 (31.14) 1.186 (30.12)	.906 (23.01)				M18 X 1.0-6g 0.100R		
D	15	1.0000-1P-.3L-TS-2A	1.289 (32.74) 1.249 (31.72)	.969 (24.61)				M22 X 1.0-6g 0.100R		
E	17	1.1875-1P-.3L-TS-2A	1.382 (35.10) 1.342 (34.09)	1.062 (26.97)				M25 X 1.0-6g 0.100R		
F	19	1.2500-1P-.3L-TS-2A	1.476 (37.49) 1.436 (36.47)	1.156 (29.36)				M28 X 1.0-6g 0.100R		
G	21	1.3750-1P-.3L-TS-2A	1.582 (40.18) 1.542 (39.17)	1.250 (31.75)				M31 X 1.0-6g 0.100R		
H	23	1.5000-1P-.3L-TS-2A	1.739 (44.17) 1.699 (43.15)	1.375 (34.92)	.171 (4.34) .083 (2.11)	.790 (20.07) .741 (18.82)	.791 (20.09) .736 (18.69)	M34 X 1.0-6g 0.100R	.138-32 UNC-2B	M4 X 0.7
J	25	1.6250-1P-.3L-TS-2A	1.884 (47.85) 1.824 (46.33)	1.500 (38.10)				M37 X 1.0-6g 0.100R		

WALL-MOUNT RECEPTACLE CUTOUT

Shell Code	Shell Size	Ø BB Min	Ø CC Min	Ø DD Holes	EE1 Bsc
B	11	.796 (20.22)	.625 (15.88)	.133 (3.38) .123 (3.12)	.812 (20.62)
C	13	.922 (23.42)	.750 (19.05)		.906 (23.01)
D	15	1.047 (26.59)	.906 (23.01)		.969 (24.61)
E	17	1.219 (30.96)	1.016 (25.81)		1.062 (26.97)
F	19	1.297 (32.94)	1.141 (28.98)		1.156 (29.36)
G	21	1.422 (36.12)	1.266 (32.16)		1.250 (31.75)
H	23	1.547 (39.29)	1.375 (34.92)	.159 (4.04) .149 (3.78)	1.375 (34.92)
J	25	1.672 (42.47)	1.484 (37.69)	.155 (3.94) .145 (3.68)	1.500 (38.10)