

180-147 Square Flange Mount Receptacle, 4-channel MIL-DTL-83526 type

RUGGED FIELD / EXPANDED BEAM

HOW TO ORDER	
Sample Part Number	180-147 ZR -N 1 F 1
Basic Number	Hermaphroditic GFOCA square flange receptacle, 4 channel
Material/Finish	See Material and Finish Table
Alignment Sleeve Style	N = None. Consult factory for additional options
Insert Cap Key	1, 2, 3, 4 (See Insert Cap Key Table)
Dust Cover Style	F = Female H = Hermaphroditic N = None
Seal Material	See Seal Material Table

MATERIAL AND FINISH

- Misc. hardware: Stainless steel/passivate
- Insert Cap: Al Alloy / anodize
- Lanyard: Stainless steel/coated

NOTES

- Connector assembly is designed IAW the interface requirements of MIL-DTL-83526/17 (Draft).

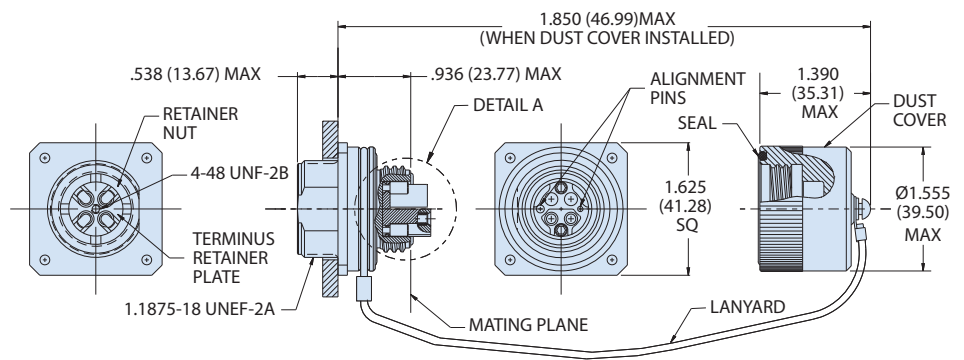

MATERIAL AND FINISH		
Code	Material	Finish Description
G2	Aluminum Alloy	Hard Anodize, Gray
ZN		Zinc-Nickel, Olive Drab
ZR		Zinc-Nickel, Black (RoHS)
Z1	Stainless	Passivate
ZL	Steel	Electrodeposited Nickel

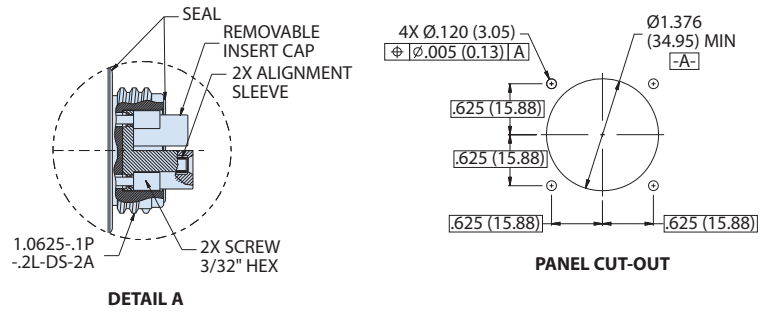

SEAL MATERIAL	
No.	Seal Material(s)
1	Fluorosilicone with Fluorosilicone panel seal
2	Fluorosilicone with conductive fluorosilicone panel seal
3	EPDM with EPDM panel seal
4	EPDM with conductive EPDM panel seal

INSERT CAP KEY CONFIGURATIONS				
Dash No:	1	2	3	4
Config.	Key 1	Key 2	Key 3	Key U (universal)