

**180-150 Square Flange Mount Receptacle with Accessory Threads, 4-channel, MIL-DTL-83526 type**

RUGGED FIELD / EXPANDED BEAM

HOW TO ORDER						
<b>Sample Part Number</b>	<b>180-150</b>	<b>ZR</b>	<b>-N</b>	<b>1</b>	<b>F</b>	<b>1</b>
<b>Basic Number</b>	Hermaphroditic GFOCA square flange mount receptacle with accessory threads					
<b>Material/Finish</b>	See Material and Finish Table					
<b>Alignment Sleeve Style</b>	N = None. Consult factory for additional options					
<b>Insert Cap Key</b>	1, 2, 3, 4 (See Insert Cap Key Table)					
<b>Dust Cover Style</b>	F = Female H = Hermaphroditic N = None					
<b>Seal Material</b>	See Seal Material Table					

**MATERIAL AND FINISH**

- Internal hardware: Al alloy/ anodize
- Misc. hardware: Stainless steel/ passivate
- Lanyard: Stainless steel/coated

**NOTES**

- Connector assembly is designed IAW the interface requirements of MIL-PRF-83526/17 (Draft).
- Accessory threads per shell size 19, D38999 Series III connector.

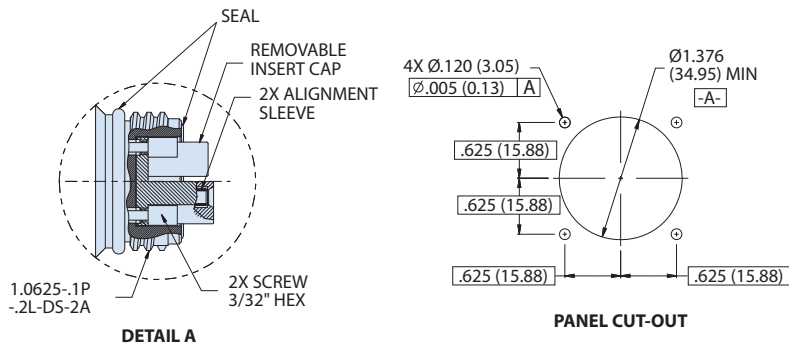
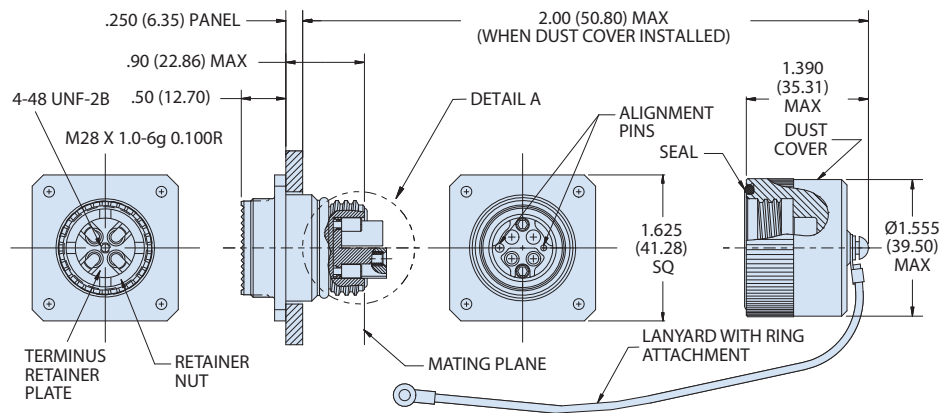

MATERIAL AND FINISH		
Code	Material	Finish Description
G2	Aluminum Alloy	Hard Anodize, Gray
ZN		Zinc-Nickel, Olive Drab
ZR		Zinc-Nickel, Black (RoHS)
Z1	Stainless Steel	Passivate
ZL		Electrodeposited Nickel

SEAL MATERIAL	
No.	Seal Material(s)
1	Fluorosilicone with Fluorosilicone panel seal
2	Fluorosilicone with conductive fluorosilicone panel seal
3	EPDM with EPDM panel seal
4	EPDM with conductive EPDM panel seal

INSERT CAP KEY CONFIGURATIONS				
Dash No:	1	2	3	4
Config.	Key 1	Key 2	Key 3	Key U (universal)