

180-188 Internal Mount Square Flange Receptacle with Accessory Threads, 4-channel, MIL-DTL-83526 type

RUGGED FIELD / EXPANDED BEAM

| HOW TO ORDER | |
|-------------------------------|---|
| Sample Part Number | 180-188 ZR -N 1 F 1 |
| Basic Number | Hermaphroditic GFOCA internal mount square flange receptacle with accessory threads |
| Material/Finish | See Material and Finish Table |
| Alignment Sleeve Style | N = None. Consult factory for additional options |
| Insert Cap Key | 1, 2, 3, 4 (See Insert Cap Key Table) |
| Dust Cover Style | F = Female N = None |
| Seal Material | See Seal Material Table |

MATERIAL AND FINISH

- Internal hardware: Al alloy/ anodize
- Misc. hardware: Stainless steel/passivate
- Lanyard: Stainless steel/coated

NOTES

- Connector assembly is designed IAW the interface requirements of MIL-PRF-83526/17 (Draft).
- Accessory threads per shell size 19, D38999 Series III connector.

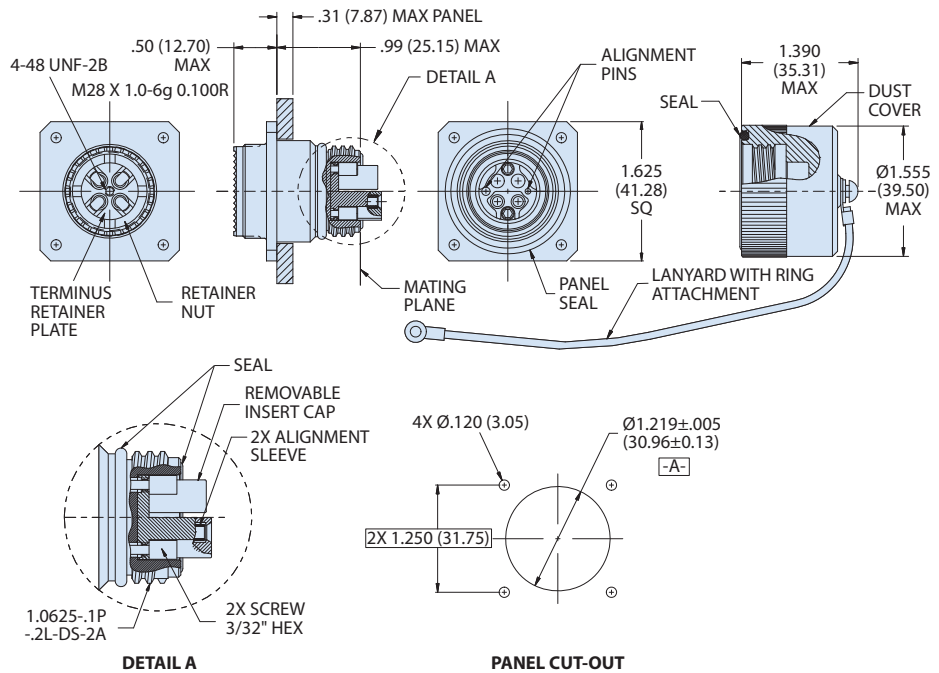

| MATERIAL AND FINISH | | |
|---------------------|-----------------|---------------------------|
| Code | Material | Finish Description |
| G2 | Aluminum Alloy | Hard Anodize, Gray |
| ZN | | Zinc-Nickel, Olive Drab |
| ZR | | Zinc-Nickel, Black (RoHS) |
| Z1 | Stainless Steel | Passivate |
| ZL | | Electrodeposited Nickel |

| SEAL MATERIAL | |
|---------------|--|
| No. | Seal Material(s) |
| 1 | Fluorosilicone with Fluorosilicone panel seal |
| 2 | Fluorosilicone with conductive fluorosilicone panel seal |
| 3 | EPDM with EPDM panel seal |
| 4 | EPDM with conductive EPDM panel seal |

| INSERT CAP KEY CONFIGURATIONS | | | | |
|-------------------------------|---|---|---|--|
| Dash No: | 1 | 2 | 3 | 4 |
| Config. | <p>Key 1</p> <p>2X .139 .137 .043 .002 TYP Key Polarization Marking</p> | <p>Key 2</p> <p>.084 .082 .162 .160 .159 .157</p> | <p>Key 3</p> <p>.162 .160 .084 .082 .159 .157</p> | <p>Key U (universal)</p> <p>2X .162 .160 4X CAVITY MARKING</p> |