

Eye-Beam™ GMA

M83526 type Low-Profile Receptacle breakout assembly

RUGGED FIELD / EXPANDED BEAM



REFERENCE PART NUMBER*	
Sample Part Number	FA03937 -80 -1 -3 -1 -4 -36-12
Basic number	GMA Fiber Optic cable
GMA Connector Type	-70 = Wall mount receptacle -80 = Jam nut mount receptacle
Fiber Type	-1 = Singlemode 9/125 -2 = Multimode 50/125 -3 = Multimode 62.5/125
Wavelength	-1 = Multimode 850 nm -2 = Multimode 1300 nm -3 = Singlemode 1310 nm -4 = Singlemode 1550 nm
Pigtail Connector Type	-0 = ST M83522/16 style -4 = SC duplex -7 = LC duplex -1 = ST connector -5 = SMA connector (906) -8 = SMA connector (905) -2 = FC connector -6 = LC connector -9 = Customer specified -3 = SC connector
Number of Fibers	-2 = 2 channel -4 = 4 channel
Length (L1, L2)	in inches. -L1 = overall length -L2 = breakout length

* Use this part number for reference only. A unique Glenair part number will be assigned to your cable order

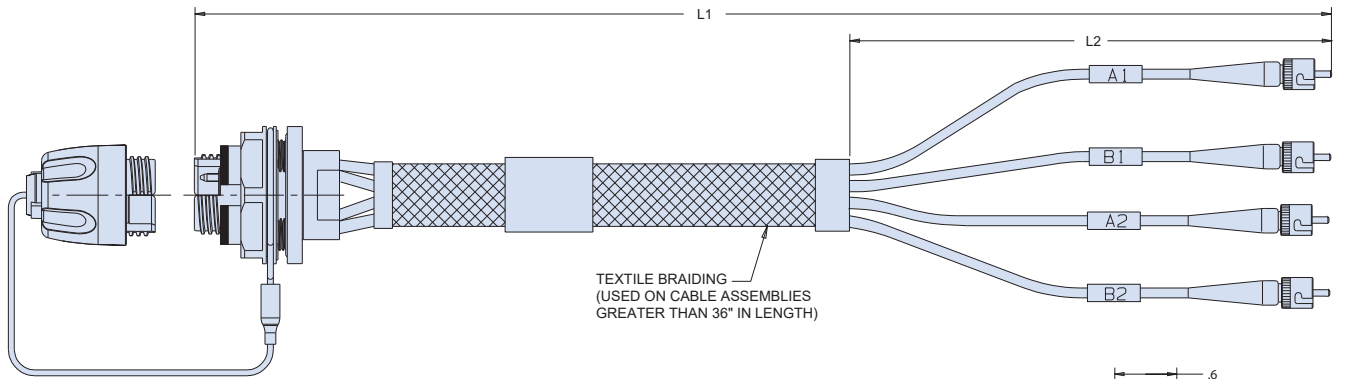

OPTICAL PERFORMANCE

- <1.0dB at 850nm multimode
- <1.5dB at 1310nm singlemode

