

FRONT-RELEASE GFR Fiber Optic Connection System



Micro-Miniature Circular 180-132 (04) Jam Nut Receptacle w/ Wire Holes

GFR FRONT-RELEASE SYSTEM



Micro-Miniature Circular GFR Jam Nut Receptacle with Safety Wire Holes. Supports from two to twelve GFR pin or socket termini with insertion loss performance comparable to industry-standard MIL-PRF-29504. Precision-machined with O-ring environmental seal. Back-end threads and teeth accept Glenair Mighty Mouse accessories. Available in aluminum and stainless steel. Termini sold separately. Supports single- and dual-O-ring termini.

HOW TO ORDER						
Sample Part Number	180-132	M	04	-9-4	P	A
Series	GFR Micro Miniature Circular					
Material / Finish	See Material/Finish table					
Connector Style	04- Jam Nut Receptacle with Safety Wire Holes					
Shell Size/Insert Arr.	9-2, 9-4, 13-8, 16-12					
Contact Type	P - Pin Termini S - Socket Termini					
Key Polarization	A, B, C, D (See Key Polarization table). Omit for 9-2 Arrangement which has 2 Keys/Keyways only.					

MATERIAL AND FINISH

- O-ring: fluorosilicone
- Insulator: Al Alloy / Anodize

NOTES

- Fiber Optic Pin or Socket Termini 181-012/181-011 to be ordered separately

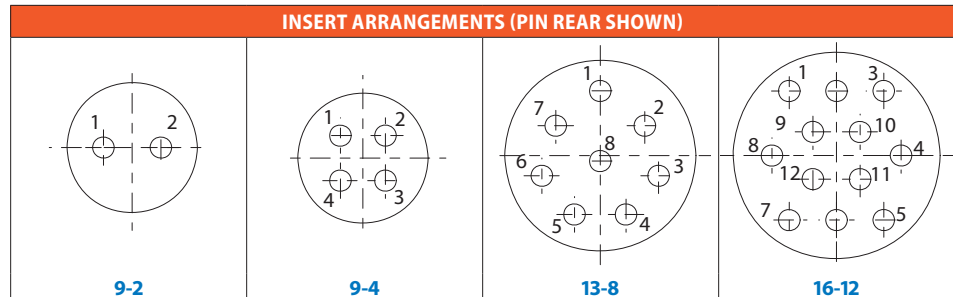

MATERIAL/FINISH		
Code	Material	Finish
C	Aluminum Alloy	Anodize, Black
M		Electroless Nickel
NF		Cadmium, Olive Drab over Electroless Nickel
ZN		Zinc-Nickel, Olive Drab over Electroless Nickel
ZNU		Black Zinc-Nickel over Electroless Nickel
Z1	Stainless Steel	Passivate

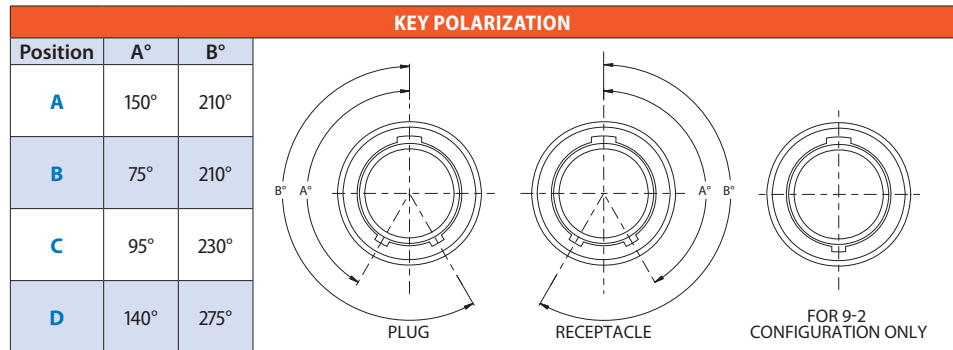

Micro-Miniature Circular
180-132 (04) Jam Nut Receptacle w/ Wire Holes

SHELL SIZE AND DIMENSIONS

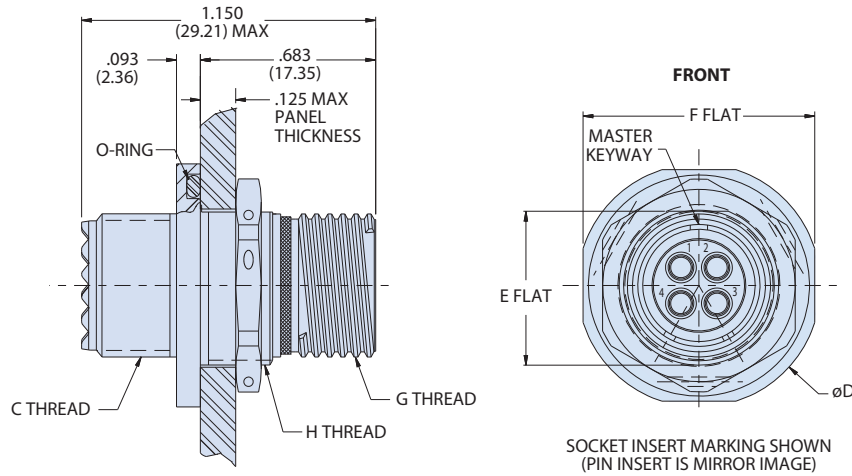

Shell Size	Ø D	E Flat	F Flat	G Thread	H Thread	C Thread
9	0.830 (21.08)	0.596 (15.14)	0.790 (20.07)	.5625-.05P-.1L-2A	.6250-32 UN-2A	.5625-24 UNEF-2A
13	1.078 (27.38)	0.845 (21.46)	1.044 (26.52)	.8125-.1P-.2L-2A	.8750-28 UN-2A	.6875-24 UNEF-2A
16	1.264 (32.11)	1.022 (25.96)	1.230 (31.24)	1.000-.1P-.2L-2A	1.0625-20 UN-2A	.9375-20 UNEF-2A

RECOMMENDED PANEL CUTOUT

	Shell Size	Ø K	L Flat
	9	0.635 (16.13)	0.611 (15.52)
			0.607 (15.42)
	13	0.885 (22.48)	0.861 (21.87)
			0.857 (21.77)
	16	1.075 (27.30)	1.040 (26.42)
			1.036 (26.31)

GFR FRONT-RELEASE SYSTEM