

GHD High-Density Insert Arrangement 180-131 Fiber Optic Test Adapter, Plug and Receptacle

KITS AND TOOLS

GHD test adapter, plug and receptacle

HOW TO ORDER						
Sample Part Number	180-131	M	06	13	6	N
Basic Number	180-131 Fiber Optic Test Adapter, Plug and Receptacle					
Material/Finish	M = Aluminum alloy/electroless nickel					
Connector Type	06 = Plug Adapter 07 = Receptacle Adapter					
Shell Size	See Dimensions table					
Insert Arrangement	Per MIL STD-1560 (See Dimensions table)					
Alternate Keying Positions	N, A, B, C, D & E					

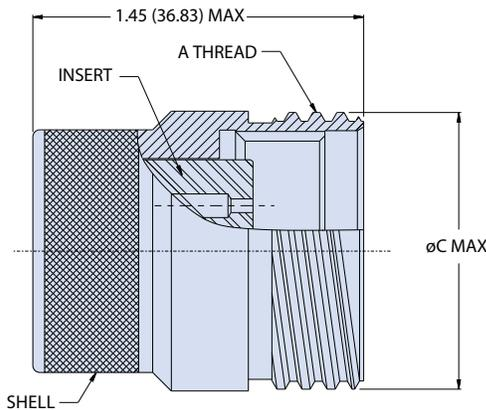

07 - RECEPTACLE ADAPTER
FOR USE WITH PLUG CONNECTOR

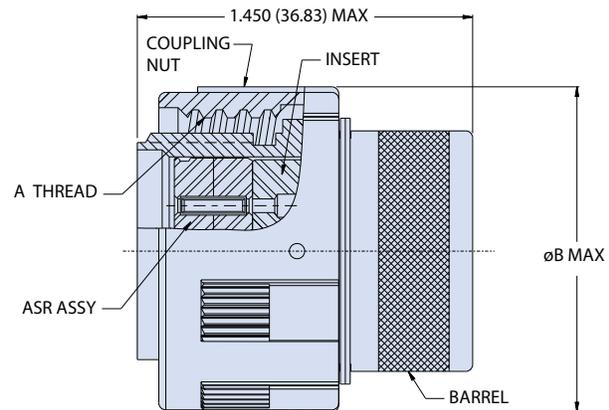

06 - PLUG ADAPTER
FOR USE WITH RECEPTACLE CONNECTOR

07 Receptacle and 06 Plug Adapter U.S. PATENT NO. 5,960,137

Dimensions					
Shell Size	Shell Size Code	No of Contacts	A Thread 0.P-0.3L-TS-2	Ø B	Ø C
11	B	4	0.7500	0.984	0.750
13	C	6	0.8750	1.157	0.875
15	D	16	1.0000	1.280	1.000
17	E	22	1.1875	1.406	1.188
19	F	30	1.2500	1.516	1.250
21	G	40	1.3750	1.642	1.375
23	H	52	1.5000	1.768	1.500
25	J	70	1.6250	1.890	1.625

GHD High-Density Insert Arrangement 180-131 Fiber Optic Test Adapter, Plug and Receptacle

GHD high-density insert arrangements

RECEPTACLE INSERT REAR FACE SHOWN — PLUG REAR FACE - OPPOSITE

MASTER KEY/KEYWAY
ORIENTATION

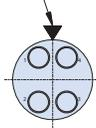

SHELL SIZE 11
ARRANGEMENT 4

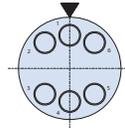

SHELL SIZE 13
ARRANGEMENT 6

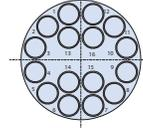

SHELL SIZE 15
ARRANGEMENT 16

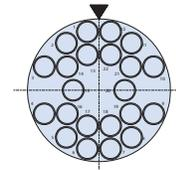

SHELL SIZE 17
ARRANGEMENT 22

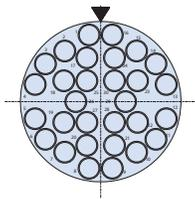

SHELL SIZE 19
ARRANGEMENT 30

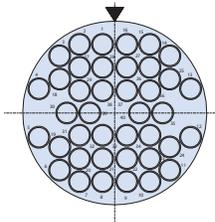

SHELL SIZE 21
ARRANGEMENT 40

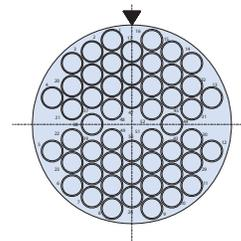

SHELL SIZE 23
ARRANGEMENT 52

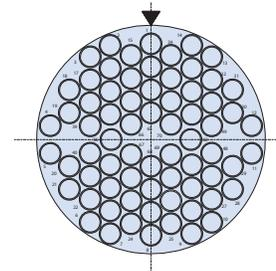

SHELL SIZE 25
ARRANGEMENT 70

KITS AND TOOLS

NOTES

- Materials and Finish
 Barrel Shell: aluminum alloy/nickel
 Coupling Nut: Hi-Grade Engineering Thermoplastic
 Insert: high-grade engineering thermoplastic or aluminum alloy/anodize; Mfr's option
 Alignment Sleeve: Zirconia Ceramic
 Contact retention clip: copper alloy
 Alignment sleeve retainer (ASR): aluminum alloy/anodized
 Insert retainer: aluminum alloy/anodized
 Miscellaneous hardware: stainless steel
- Connector adapters designed for use with Glenair 180-122 series GHD connectors
- Alignment sleeve retainer (ASR) is supplied with plug adapter only. To order separately, see Glenair drawing 180-122ASR
- "For fiber optic test probe jumber, see Glenair drawings:
 - FA00861 = Non-keyed probe (181-061), PC polish
 - FO04309 = Keyed probe (181-062), APC polish