

MIL-DTL-38999 Series III
180-073 (07) Fiber Optic Test Adapter, Receptacle

MIL-DTL-38999 test adapter (receptacle)

HOW TO ORDER							
Sample Part Number	180-073	M	07	25	24	P	A
Basic Number	180-073 Fiber Optic Test Adapter, Receptacle						
Material/Finish	See Material and Finish table						
Connector Style	07 = Receptacle Adapter						
Shell Size	See Shell Size and Insert Arrangements table						
Insert Arrangement	Per MIL-STD-1560 (See Shell Size and Insert Arrangements table)						
Insert Type	P = Pin S = Socket (with alignment sleeves)						
Alternate Keying Position	N, A, B, C, D & E Per MIL-DTL-38999, Series III Omit keying designator to receive universal single key (master) only. This option not recommended for larger shell sizes (19-25)						

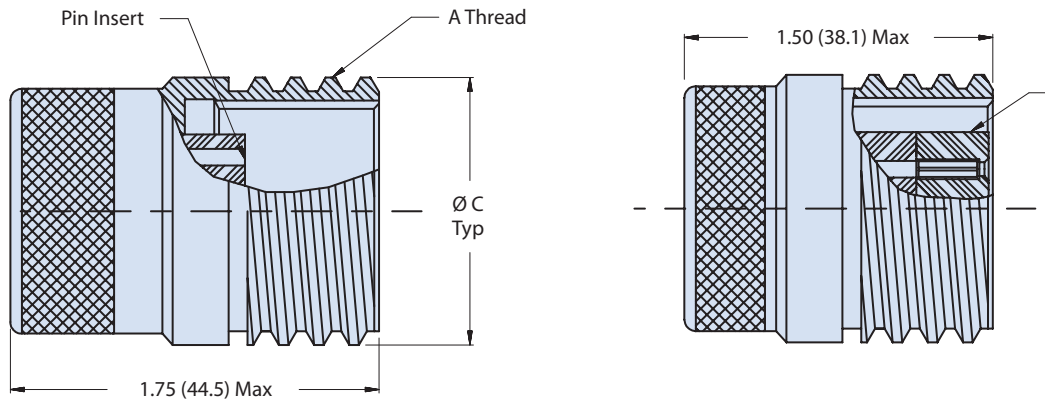

07 - RECEPTACLE ADAPTER
FOR USE WITH PLUG CONNECTOR

U.S. PATENT NO. 5,960,137

MATERIAL AND FINISH

Shell: See Material and Finish table
Insert: Hi-Grade Engineering Thermoplastic
Alignment Sleeve: Zirconia Ceramic
Retaining Clips: BeCu Alloy
Lock Nut: Al Alloy/Anodize

NOTES

For fiber optic test probe jumper, see Glenair drawing ABC54705
For fiber optic test probe (low profile, probe-to-probe) jumper see Glenair drawing FO03187
25-37 insert cavity spacing too close to probe using one adapter. 2 adapters (25-37A and 25-37B) are required
Shell size 23 for insert 23-66 only is made of 300 series stainless steel
Cavity markings applied to rear insert face only

MIL-DTL-38999 Series III
180-073 (07) Fiber Optic Test Adapter, Receptacle

KITS AND TOOLS

FRONT FACE OF PIN AND SOCKET INSULATORS SHOWN, REAR SURFACE OPPOSITE

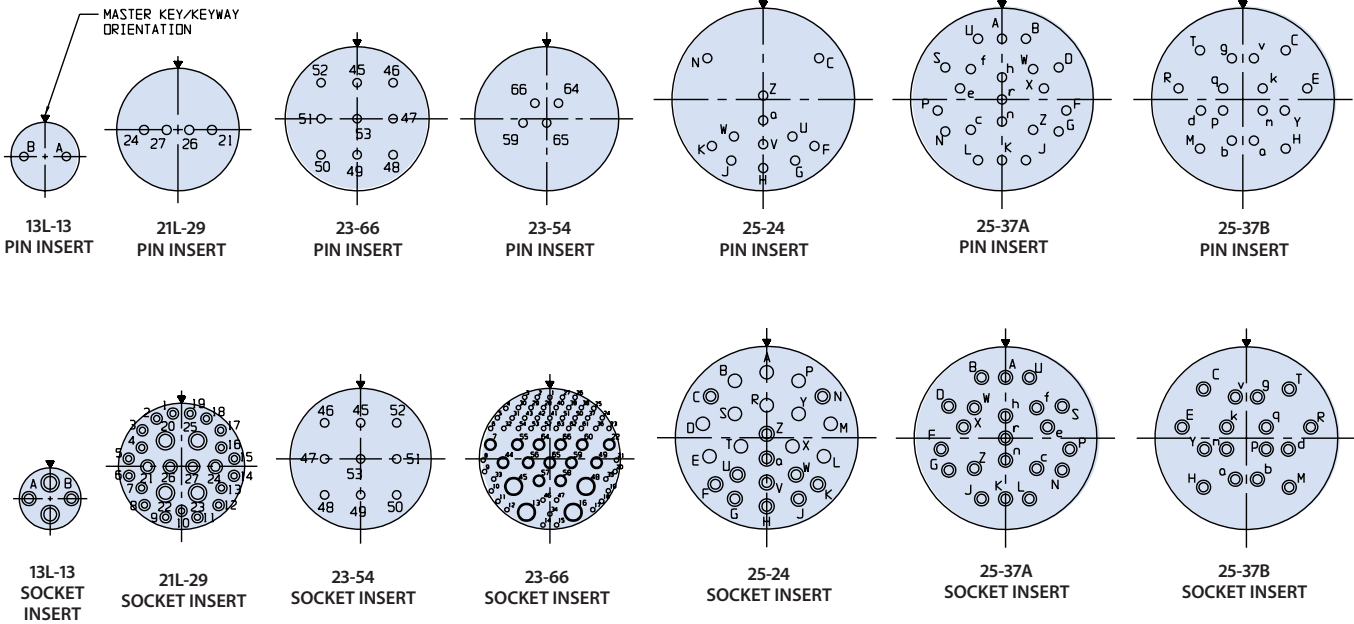

Shell Size and Insert Arrangements				
Shell Size	Shell Size Code (Ref)	Insert Arrangement Dash No.	A Thread 0.1P-0.3L-TS-2	Ø C Max
13	C	13L-13	.875 (22.2)	.875 (22.2)
21	G	21L-29	1.375 (34.9)	1.375 (34.9)
23	H	23-54	1.500 (38.1)	1.500 (38.1)
23	H	23-66	1.500 (38.1)	1.500 (38.1)
25	J	25-24	1.625 (41.3)	1.625 (41.3)
25	J	25-37A	1.625 (41.3)	1.625 (41.3)
25	J	25-37B	1.625 (41.3)	1.625 (41.3)

Finish		
Code	Material	Finish
M	Aluminum Alloy	Electroless Nickel
NF		Cadmium, Olive Drab
Z1	Stainless Steel	Passivate