

180-102 Fiber Optic Probe Adapter, Plug and Receptacle for NGCON Fiber Optic Connectors

KITS AND TOOLS

Fiber optic plug and receptacle probe adapter for use with 180-071 connectors

HOW TO ORDER				
Sample Part Number	180-102	NF	07	1
Basic Number	180-102 Fiber Optic Probe Adapter, Plug and Receptacle			
Material/Finish	See Material and Finish table			
Adapter Type	06 = Plug Adapter 07 = Receptacle Adapter			
Alternate Keying Position	1, 2, 3, 4, & 5			

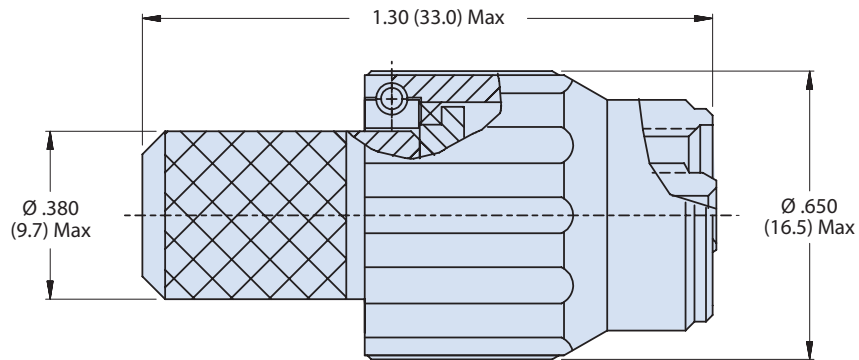

06 Plug Adapter
 U.S. PATENT NO. 5,960,137

Material and Finish		
Code	Material	Finish
C	Aluminum	Anodize, Black
M	Aluminum Alloy	Electroless Nickel
NF	Aluminum	Cadmium, Olive Drab

MATERIAL AND FINISH

Receptacle

Shell, Rear body: See Material and Finish table
 Retaining Clips: BeCu Alloy
 Misc. Hardware: Stainless Steel
 Seal: Fluorosilicone

Plug

Barrel, Coupling Nut, Rear body: See Material and Finish table
 Retaining Clips: BeCu Alloy
 Misc. Hardware: Stainless Steel/Passivate
 O-Ring: Fluorosilicone

NOTES

For fiber optic test probe jumper, see Glenair drawing ABC54705

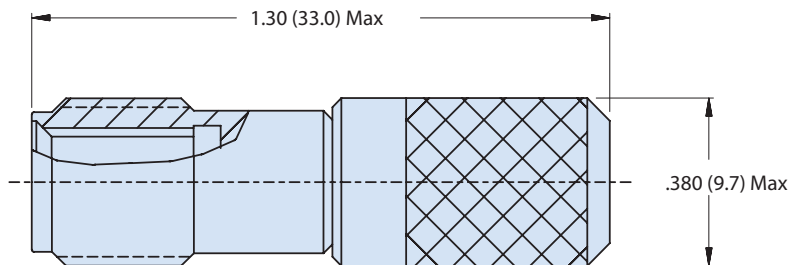

07 Receptacle Adapter
 U.S. PATENT NO. 5,960,137