

180-091 (T7) (TM) Wall mount receptacle, threaded holes • Multi-channel

SuperNine® MIL-DTL-38999 Type



Tight-tolerance MIL-DTL-38999 Series III type Wall-Mount Receptacle, threaded holes. Compatible with Size 16 snap-in, rear-release MIL-PRF-29504 pin and socket termini (Glenair Series 181-001 and 181-002). Fully shielded for hybrid electrical contact applications. Precision-manufactured for optimum optical fiber alignment and low dB data loss performance. Robust anti-decoupling and environmental sealing for use in high vibration, shock, and high altitude aerospace and military/defense applications. Shell materials include Aluminum alloy, composite thermoplastic, stainless steel, and marine bronze. Keyed polarization for mis-mate protection. Available insert arrangements support from two to thirty-seven singlemode and multimode termini.

MATERIAL AND FINISH

- Insulator: High Grade Rigid Dielectric
- Seals: Fluorosilicone
- Retention Clips: BeCu Alloy

NOTES

- Blue color band indicates rear-release retention system. Yellow color band indicates fiber optic connector. Bands located approximately as shown, sequencing optional.
- See pages B-4 to B-15 for compatible Glenair terminus part numbers.
- Recommended Insertion/Extraction tool: P/N M81969/14-03 or equivalent

HOW TO ORDER							
Sample Part Number	180-091	XW	T7	-17	-8	P	N
Basic Number	D38999 Series III Type						
Material/Finish	See Material and Finish table						
Connector Style	T7 = Wall Mount Receptacle with Threaded insert holes						
Shell Size	See Dimensions table						
Insert Arrangement	See Contact Arrangements images						
Insert Designation	P = Pin S = Socket						
Alternate Key Position	A, B, C, D, E; N = Normal (Per MIL-DTL-38999)						

MATERIAL AND FINISH		
Code	Material	Finish Description
M*	Aluminum Alloy	Electroless Nickel
MA		Electroless Nickel, Matte
ME		Electroless Nickel
MT		Nickel-PTFE, Gray
NF		Cadmium, Olive Drab
TZ		Tin-Zinc, Bronze-Gold
ZN		Zinc-Nickel, Olive Drab
ZNU		Zinc-Nickel, Black
ZR		Zinc-Nickel, Black (RoHS)
XM		Composite
XMT	Nickel - PTFE, Grey	
XW	Cadmium, Olive Drab	
XZN	Zinc-Nickel, Black	
MS	Stainless Steel	Electroless Nickel
ZL		Electro-Deposited Nickel
ZI	Marine Bronze	Passivate
AB		No Plating

*Inactive for new design. Use "ME" finish.

INSERT ARRANGEMENTS (mating face, pin insert shown)

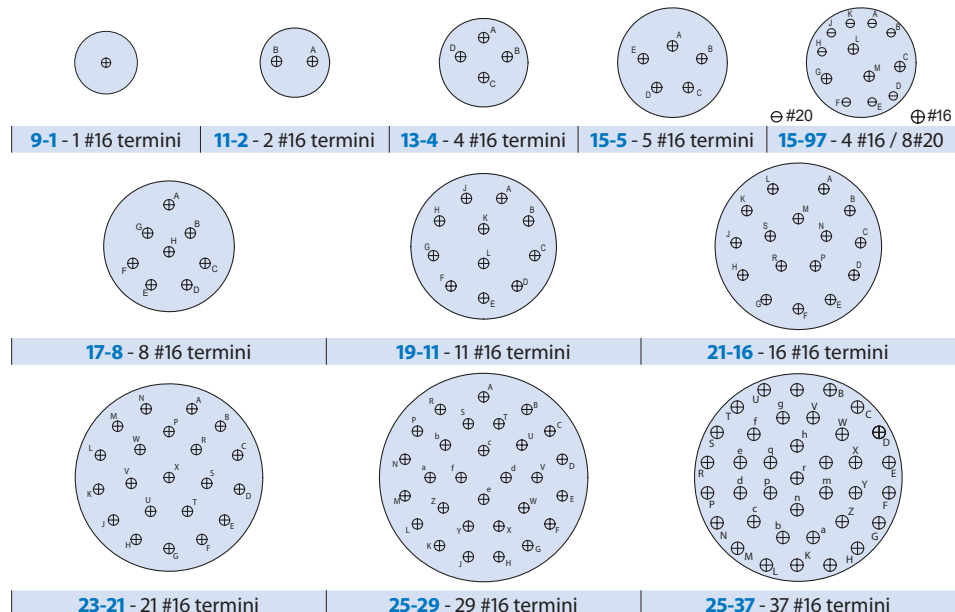

180-091 (T7) (TM) Wall mount receptacle, threaded holes • Multi-channel

T7 - WALL MOUNT RECEPTACLE SQUARE FLANGE WITH THREADED INSERT HOLES

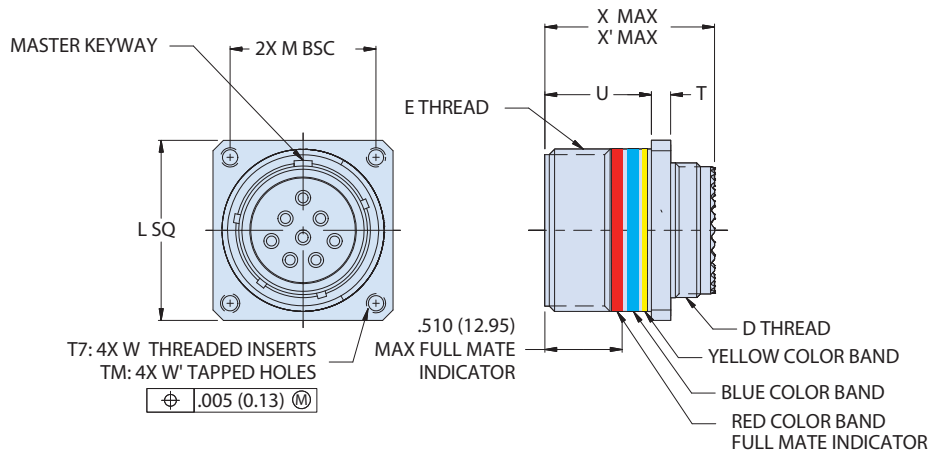

Shell Size Code	Shell Size	A Thread	B SQ	C BSC	G	H	J Thread	L Threaded Insert Holes
A	9	.6250-1P-.3L-TS-2A	.949 (24.1) .929 (23.6)	.719 (18.3)	.144 (3.7) .083 (2.1)	.823 (20.9) .768 (19.5)	M12 x 1.0-6g 0.100R	.112-40 UNC-2B
B	11	.7500-1P-.3L-TS-2A	1.043 (26.5) 1.019 (25.9)	.812 (20.6)			M15 x 1.0-6g 0.100R	
C	13	.8750-1P-.3L-TS-2A	1.138 (28.9) 1.114 (28.3)	.906 (23.0)			M18 x 1.0-6g 0.100R	
D	15	1.0000-1P-.3L-TS-2A	1.232 (31.3) 1.208 (30.7)	.969 (24.6)			M22 x 1.0-6g 0.100R	
E	17	1.1875-1P-.3L-TS-2A	1.323 (33.6) 1.299 (33.0)	1.062 (27.0)			M25 x 1.0-6g 0.100R	
F	19	1.2500-1P-.3L-TS-2A	1.449 (36.8) 1.425 (36.2)	1.156 (29.4)			M28 x 1.0-6g 0.100R	
G	21	1.3750-1P-.3L-TS-2A	1.575 (40.0) 1.551 (39.4)	1.250 (31.8)	.171 (65.2) .083 (39.8)	.791 (20.0) .736 (18.7)	M31 x 1.0-6g 0.100R	.138-32 UNC-2B
H	23	1.5000-1P-.3L-TS-2A	1.701 (43.2) 1.677 (42.6)	1.375 (34.9)			M34 x 1.0-6g 0.100R	
J	25	1.6250-1P-.3L-TS-2A	1.823 (46.3) 1.799 (45.7)	1.500 (38.1)			M37 x 1.0-6g 0.100R	
							M37 x 1.0-6g 0.100R	

SuperNine® MIL-DTL-38999 Type

RECOMMENDED PANEL CUTOUT DIMENSIONS

Shell Size Code	Shell Size	Wall Mount			
		Ø M Min	Ø N Min	Ø P Holes	R1 BSC
A	9	.656 (16.7)	.516 (13.11)	.133 (3.4) .123 (3.1)	.719 (18.3)
B	11	.796 (20.2)	.625 (15.9)		.812 (20.6)
C	13	.922 (23.4)	.750 (19.1)		.906 (23.0)
D	15	1.047 (26.6)	.906 (23.0)		.969 (24.6)
E	17	1.219 (31.0)	1.016 (25.8)		1.062 (27.0)
F	19	1.297 (32.9)	1.141 (29.0)		1.156 (29.4)
G	21	1.422 (36.1)	1.266 (32.2)	1.250 (31.8)	
H	23	1.547 (39.3)	1.375 (34.9)	.159 (4.0) .149 (3.8)	1.375 (34.9)
J	25	1.672 (42.5)	1.484 (37.7)	.155 (3.9) .145 (3.7)	1.500 (38.1)

Rear Panel Mount

Front Panel Mount