

630-015 Cable Bulkhead Adapter with Strain Relief and Braid Sock

SuperNine® MIL-DTL-38999 Type



Series 630-015 fiber optic cable bulkhead adapter may be ordered with optional shrink sleeving and/or shielded jam nut assembly for use with Kevlar-equipped fiber optic cable applications. Available in aluminum, composite, or stainless steel.

HOW TO ORDER					
Sample Part Number	630-015	NF	01	T	L
Basic Number	Cable bulkhead adapter				
Material/Finish	See Material and Finish table				
Dash Number	See Dimensions table				
Connector Type	Supplied with 447-822*** Shield Nut Instead of Jam Nut (Omit Letter T for Part with Jam Nut)				
Shrink Sleeve	L = Less shrink sleeve Omit for standard (with shrink sleeve)				

DIMENSIONS

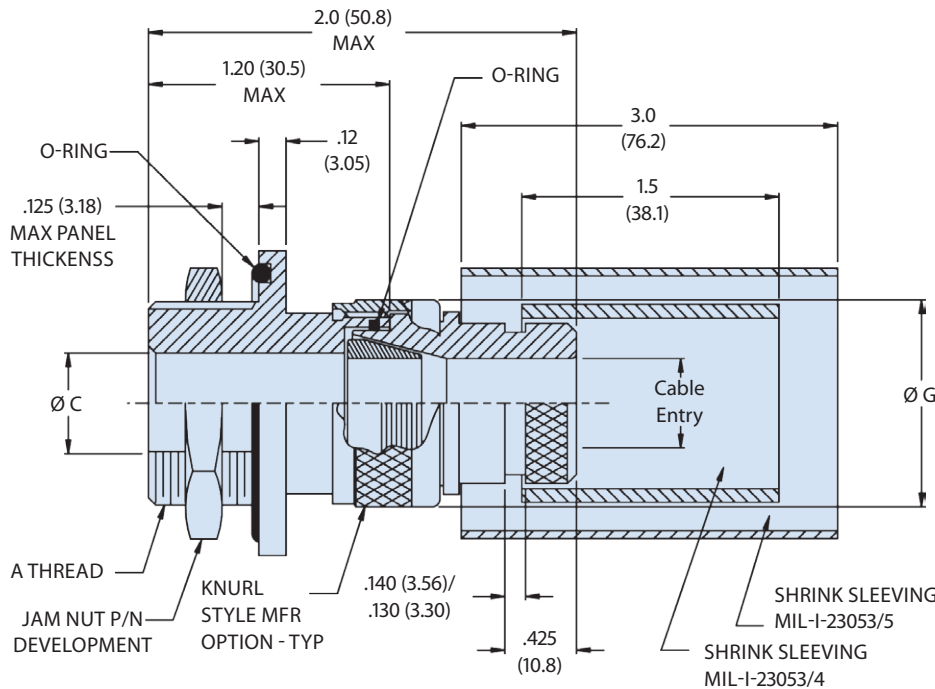

Shell Size	A Thread Class 2A	ØB Max	ØC +.010 -0.000	ØD +.010 -0.000	E +.010 -0.000	F	ØG Max	H Ref	Max. Cable Entry	MIL-I-23053 Shrink Sleeve	MIL-I-23053 Shrink Sleeve	Braid Sock 103-005-005 Ref
01	3/4-20 UNEF	1.140 (29.0)	.340 (8.64)	.755 (19.2)	.691 (17.6)	.938 (23.8)	1.004 (25.5)	6.0	.335	/4-204-0	/5-109-0	A10
02	3/4-20 UNEF	1.140 (29.0)	.460 (11.7)	.755 (19.2)	.691 (17.6)	.938 (23.8)	1.132 (28.8)	6.0	.455	/4-204-0	/5-109-0	A10
03	7/8-20 UNEF	1.280 (32.5)	.630 (16.0)	.880 (22.4)	.816 (20.7)	1.062 (27.0)	1.343 (34.1)	6.0	.625	/4-205-0	/5-110-0	A10
04	1 1/16-18 UNEF	1.490 (37.8)	.755 (19.2)	1.067 (27.1)	1.004 (25.5)	1.250 (31.8)	1.468 (37.3)	6.0	.750	/4-206-0	/5-110-0	A14
05	1 3/16-18 UNEF	1.640 (41.7)	.880 (22.4)	1.192 (30.3)	1.130 (28.7)	1.375 (35.0)	1.593 (40.5)	6.0	.875	/4-206-0	/5-111-0	A16
06	1 5/16-18 UNEF	1.930 (49.0)	1.005 (25.7)	1.317 (33.5)	1.254 (31.9)	1.625 (41.3)	1.656 (42.1)	6.0	1.000	/4-305-0	/5-111-0	A18

630-015 Cable Bulkhead Adapter with Strain Relief and Braid Sock

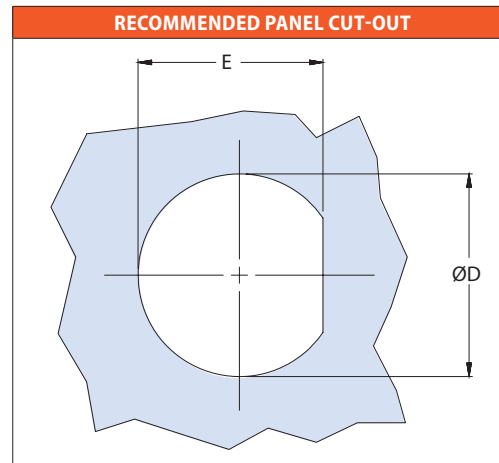
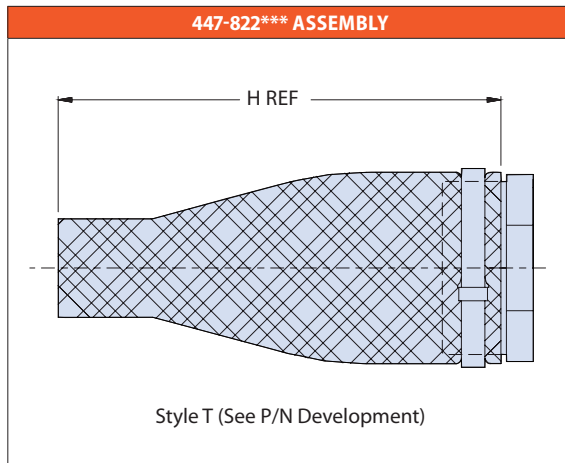

MATERIAL AND FINISH

- Adapters, Jam Nut, Ferrule, Coupling Nut: Al Alloy/see Material and Finish table
- O-Rings: Silicone
- Shrink Sleeving: Polyolefin

MATERIAL AND FINISH		
Code	Material	Finish Description
M	Aluminum Alloy	Electroless Nickel
NF		Cad/O.D. over Electroless Nickel (1000 Hr. Salt Spray)
B		Cadmium Plate/Olive Drab
N		Cadmium Plate/Olive Drab over Nickel
XMT	Composite	Nickel PTFE, Grey
Z1	Stainless Steel	Passivate

Refer to Appendix for material/finish details

NOTES

- Glenair 600 Series Backshell Assembly Tools are recommended for assembly and installation.
- MIL-I-23053/4 & /5 Shrink Sleeving to be packaged loose in a plastic bag.

SuperNine® MIL-DTL-38999 Type