

SuperNine® “Better than QPL” MIL-DTL-38999 Series III 183-002 (S7) Wall mount receptacles: slotted holes, clinch nuts, or helicoils

PRIZM® MT and MT Elite®

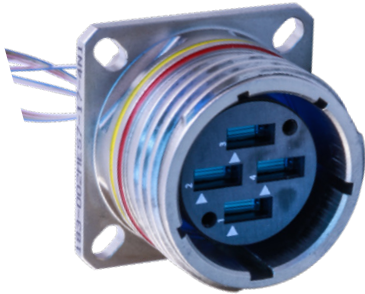

Tight-tolerance MIL-DTL-38999 Series III type Wall Mount Receptacle with slotted holes, clinch nuts, or helicoils. Supports from one to four PRIZM MT and/or MT Elite high-density ferrules (Glenair series 181-149 / 181-133) with industry-leading insertion loss performance. Precision-machined and molded with integral guide holes for optimum optical fiber alignment and low dB data loss performance. Robust anti-decoupling outperforms standard D38999 solutions in severe vibration, shock, and high altitude testing. Coupling nut and connector body materials include Aluminum alloy, composite thermoplastic, stainless steel, and marine bronze. Keyed polarization for mis-mate protection.

SUPERNINE MT WALL-MOUNT RECEPTACLE, SLOTTED HOLES, CLINCH NUTS, HELICOILS						
Sample Part Number	183-002	ME	S7	-17-4	N	1
Basic Part Number	SuperNine MT Fiber Optic Connector					
Material/Finish Code	See Material and Finish Table					
Connector Style	S7 = Wall-mount receptacle with slotted holes CM = Wall-mount receptacle with metric clinch nuts CS = Wall-mount receptacle with standard clinch nuts HM = Wall-mount receptacle with metric helicoils HS = Wall-mount receptacle with standard helicoils					
Shell Size / Insert Arrangement	11-1, 13-2, 15-3, 17-4 Order MT ferrule kit P/N 181-139					
Alternate Key Position	A, B, C, D, E, N = Normal U = Universal (per MIL-DTL-38999)					
Insert Cavity Clocking Orientation (see Table II)	1 = Standard position 2 = Cavity position rotated 45° to master key/keyway 3 = Cavity position rotated 90° to master key/keyway					

MATERIAL AND FINISH		
Code	Material	Finish Description
ME	Aluminum Alloy	Electroless Nickel
MT		Nickel-PTFE, Grey
NF		Cadmium, Olive Drab
ZR		Zinc-Nickel, Black
TZ		Tin-Zinc, Green/Gold
XM	Composite	Electroless Nickel
XW		Cadmium, Olive Drab
Z1	Stainless Steel	Passivate
ZL		Electro-Deposited Nickel

- NOTES**
- Pin (male) and socket (female) ferrule kits can be used in either plug or receptacle connectors. Preferred configuration is female ferrule in receptacle connector.
 - Wall mount receptacle with clinch nuts not available for stainless steel material finish codes.

INSERT CAVITY CLOCKING ORIENTATION				
Code	Shell Size-Arrangement 11-1	Shell Size-Arrangement 13-2	Shell Size-Arrangement 15-3	Shell Size-Arrangement 17-4
1				
2				
3				

SuperNine® “Better than QPL” MIL-DTL-38999 Series III
183-002 (S7) Wall mount receptacles: slotted holes, clinch nuts, or helicoils

PRIZM® MT and MT Elite®

S7- WALL MOUNT RECEPTACLE

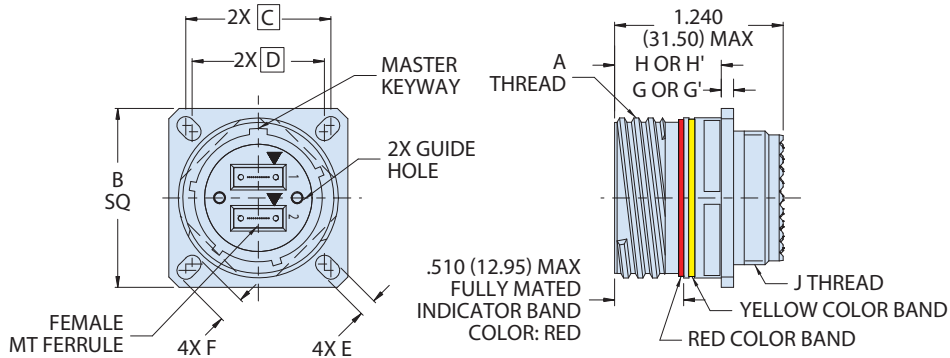

Shell Size / Insert Arr.	A Thread	B SQ	C BSC	D BSC	E	F	G	G'	H	H'	J Thread
11-1	.7500-1P-3L-TS-2A	1.043 (26.49) 1.019 (25.88)	0.812 (20.62)	.719 (18.26)	.136 (3.45) .120 (3.05)	.202 (5.13)	0.098 (2.49)	0.144 (3.66)	0.820 (20.83)	0.823 (20.90)	M15 X 1.0-6g 0.100R
13-2	.8750-1P-3L-TS-2A	1.138 (28.91) 1.114 (28.30)	0.906 (23.01)	.812 (20.62)		.186 (4.72)					M18 X 1.0-6g 0.100R
15-3	1.0000-1P-3L-TS-2A	1.232 (31.29) 1.208 (30.68)	0.969 (24.61)	.906 (23.01)		.181 (4.60) .165 (4.19)					M22 X 1.0-6g 0.100R
17-4	1.1875-1P-3L-TS-2A	1.323 (33.60) 1.299 (32.99)	1.062 (26.97)	.969 (24.61)		.202 (5.13) .186 (4.72)					M25 X 1.0-6g 0.100R

RECOMMENDED PANEL CUTOUT DIMENSIONS

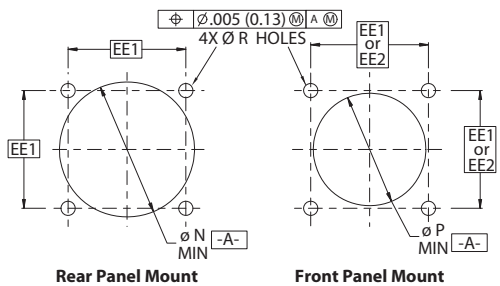

Shell Size / Insert Arr.	Wall Mount				
	Ø N MIN	Ø P MIN	Ø R Holes	EE1 BSC	EE2 BSC
11-1	.796 (20.22)	.625 (15.88)	.133 (3.38) .123 (3.12)	.812 (20.62)	.719 (18.26)
13-2	.922 (23.42)	.750 (19.05)		.906 (23.01)	.812 (20.62)
15-3	1.047 (26.59)	.906 (23.01)		.969 (24.61)	.906 (23.01)
17-4	1.219 (30.96)	1.016 (25.81)		1.062 (26.97)	.969 (24.61)

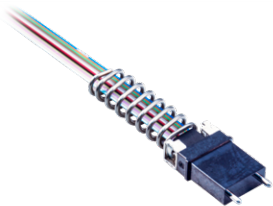

- MATERIAL/FINISH NOTES**
- Ferrule, Pin Spacer: Polyphenylene Sulfide Resin
 - Pin Clamp, Spring: Stainless Steel
 - Boot: TPE

HOW TO ORDER ELITE MT FERRULE KIT

Sample Part Number	181-139	-126	-12	M
Basic Part Number	Elite MT Ferrule kit			
Fiber type	-126, -1253, -1253A (See Fiber Type and Number table)			
Number of Fibers	-12, -24 (See Fiber Type and Number table)			
Ferrule Style	M = Male (use with Plug) F = Female (use with Receptacle)			

FIBER TYPE AND NUMBER

Dash No.	Fiber Type	End Face	Fiber Size Core/Cladding	No. of Fibers	Spring Force	Ferrule Identification	Pin Clamp Identification (Male Kit only)
-1253A	SM	APC	9/125	12	L	M-ME12	2 Triangles
				24	H	M-ME24	2 Triangles
-1253	SM	PC	9/125	12	H	E-E12	2 Triangles
-126	MM	PC	50/125 62.5/125	12	H	M-ME12	1 Triangle
				24	H	M-ME24	1 Triangle