

VITA 66.1 Backplane  
183-009-06 Plug Module connectors

PRIZM® MT and MT Elite®

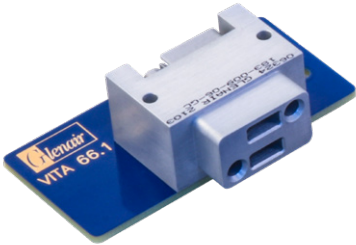

HOW TO ORDER			
Sample Part Number	183-009	-06	-GC
Basic Part Number	MT Fiber Optic Backplane Interconnect, VITA 66.1 Style		
Connector Style	-06 = Plug Module		
Material / Finish	M = Aluminum / Electroless Nickel GC = Aluminum / Clear Anodize		

**NOTES**

- Connectors are designed to meet general requirements of ANSI/VITA 66.1
- See figure 3.25-1 and table 3.25-1 of VITA 66.0 for Module Engagement requirements
- See paragraph 3.2.4 Of VITA 66.1 For dimension "A" vs. Module Insertion range requirements
- For MT ferrule kit part numbers, see Glenair drawing 181-170

CONNECTOR LOCATION ON MODULE PCB	
Position	Dim. "X"
P2	2.1154
P3	3.8012
P4	4.9350
P5	6.0689
P6	7.2028

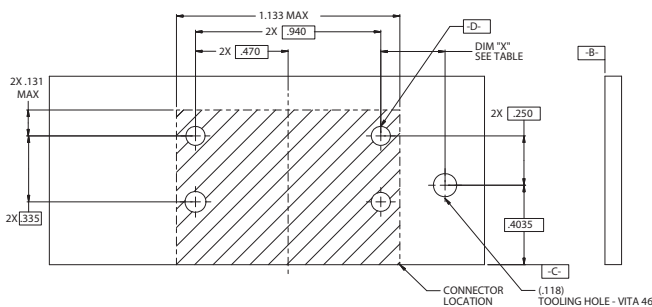
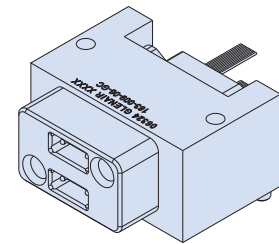
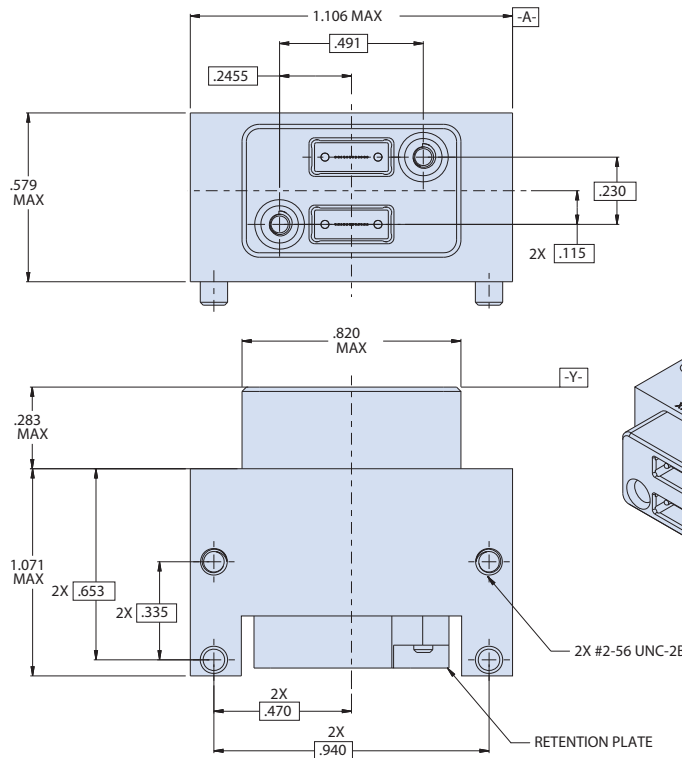

FULL-WIDTH FIBER OPTIC INTERCONNECT  
PLUG-IN MODULE INTERFACE (VITA 66.0)

