

MIL-PRF-28876 Wall-Mount Receptacle

181-040 / M29504 Termini • 930-006 / M28840/24 Panel Gasket

PIN TERMINI - HOW TO ORDER

Mil-Spec Part Number	ØA	Fiber Type	Fiber Size Core/Cladding	Commercial Part Number
M29504/14-4140C	125.0µ	SMF	9/125µm	181-039-1250C
Not listed in Mil-Spec	125.5µ	SMF	9/125µm	181-039-1255C
M29504/14-4141C	126.0µ	SMF	9/125µm	181-039-1260C
M29504/14-4131C	126.0µ	MMF	50/125, 62.5/125µm	181-039-1260C
M29504/14-4132C	127.0µ	MMF	50/125, 62.5/125µm	181-039-1270C
M29504/14-4135C	142.0µ	MMF	100/140µ	181-039-1420C

SOCKET TERMINI - HOW TO ORDER

Mil-Spec Part Number	ØA	Fiber Type	Fiber Size Core/Cladding	Commercial Part Number
M29504/15-4180C	125.0µ	SMF	9/125µ	181-040-1250C
Not listed in Mil-Spec	125.5µ	SMF	9/125µ	181-040-1255C
M29504/15-4181C	126.0µ	SMF	9/125µ	181-040-1260C
M29504/15-4171C	126.0µ	MMF	50/125, 62.5/125µ	181-040-1260C
M29504/15-4172C	127.0µ	MMF	50/125, 62.5/125µ	181-040-1270C
M29504/15-4175C	142.0µ	MMF	100/140µ	181-040-1420C

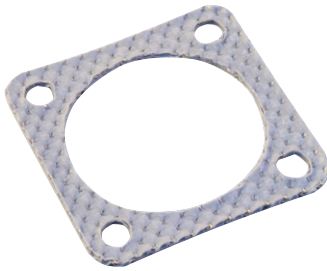

HOW TO ORDER

Sample Part Number	930-006		F	13
Basic Number	Commercial square flange wall mount receptacle panel gasket			
Material Symbol	See Material table			
Shell Size	See Shell Size table			

MATERIAL

Symbol	Material Description
F	Fluorosilicone
M	Silver Plated Glass Filled Silicone (EMI)
N	Neoprene

SHELL SIZE

Shell Size	A	Ø B	C	Ø D	F Radius
11 (A)	± .010	+ .016 - .000	+ .016 - .000	± .010	± .010
13 (B)	.750	.750	1.023	.120	.141
15 (C)	.843	.875	1.138		
23 (F)	.968	1.062	1.258		
23 (F)	1.281	1.500	1.718		.188

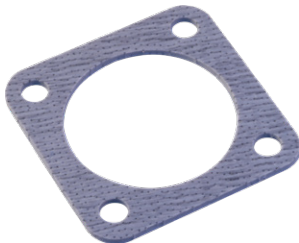
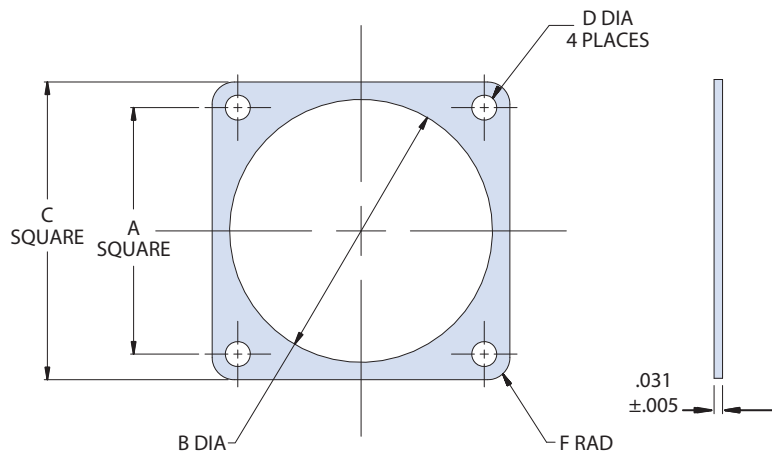

HOW TO ORDER

Sample Part Number	M28840/24		B	A
Basic Number	M28840/24 MIL-PRF square flange wall mount receptacle panel gasket			
Shell Size	See Shell Size table			
Material Designator	A - Fluorosilicone B - EMI			

SHELL SIZE

Shell Size	A	B Dia.	C	D Dia.
11 (A)	.760 (19.30)	.766 (19.46)	1.039 (26.39)	.130 (3.30) .110 (2.79)
	.740 (18.80)	.750 (19.05)	1.023 (25.98)	
13 (B)	.853 (21.67)	.891 (22.63)	1.154 (29.31)	
	.833 (21.16)	.875 (22.22)	1.138 (28.90)	
15 (C)	.978 (24.84)	1.078 (27.38)	1.274 (32.36)	
	.958 (24.33)	1.062 (26.97)	1.258 (31.95)	
23 (F)	1.291 (32.79)	1.516 (38.51)	1.734 (44.04)	
	1.271 (32.28)	1.500 (38.10)	1.718 (43.64)	

