

**189-113 Shrink Tubing and O-Rings for MIL-PRF-28876  
 Style Connectors With Backshells**

NAVSEA / Underwater Fiber Optics

HOW TO ORDER			
Sample Part Number	189-113	-13	2
Basic Number	MIL-PRF-28876-Style O-Ring for Jam Nut Mount Receptacle Connectors		
Shell Size	See Shell Size table		
Backshell Designator	See table		

**MATERIAL AND FINISH**

- Tubing: Polyolefin/ Adhesive-Lined
- O-Ring: Neoprene

**NOTES**

- For use with the following Glenair connectors with backshells, at a minimum:
  - M28876
  - 180-040
  - 187-166
  - 187-154
- Packaging identified with manufacturer's name, cage code, part number, and date code.
- For use with Glenair products only.

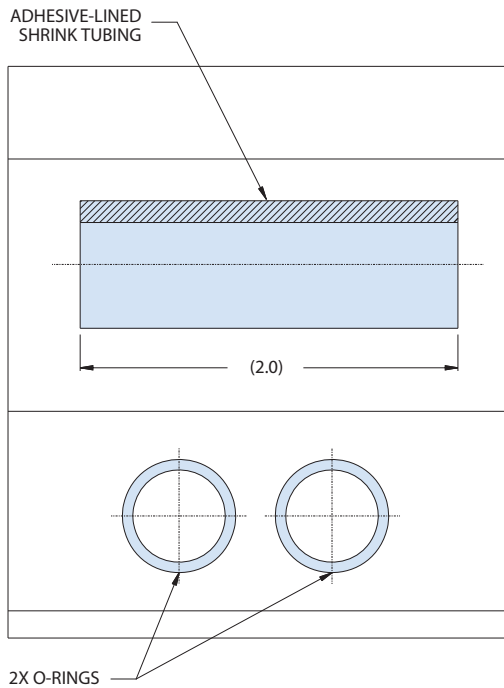

Backshell Designator	Max Allowable Cable Diameter By Shell Size			
	11 (A)	13 (B)	15 (C)	23 (F)
1	.250 (6.35)	.285 (7.24)	.500 (12.70)	.866 (22.00)
2	.346 (8.79)	.346 (8.79)	.250 (6.35)	1.000 (25.40)
3	—	.453 (11.51)	.375 (9.52)	.600 (15.24)