

930-006 Gasket for MIL-DTL-28840 and MIL-PRF-28876 Receptacle Connectors

HOW TO ORDER			
Sample Part Number	930-006	F	13
Basic Number	Mounting Gasket		
Material and Finish	See Material and Finish table		
Shell Size	See Dimensions table		

MATERIAL AND FINISH

- Gasket: see Material/Finish table.

NOTES

- Identified by bag and tag in suitable quantities.

DIMENSIONS

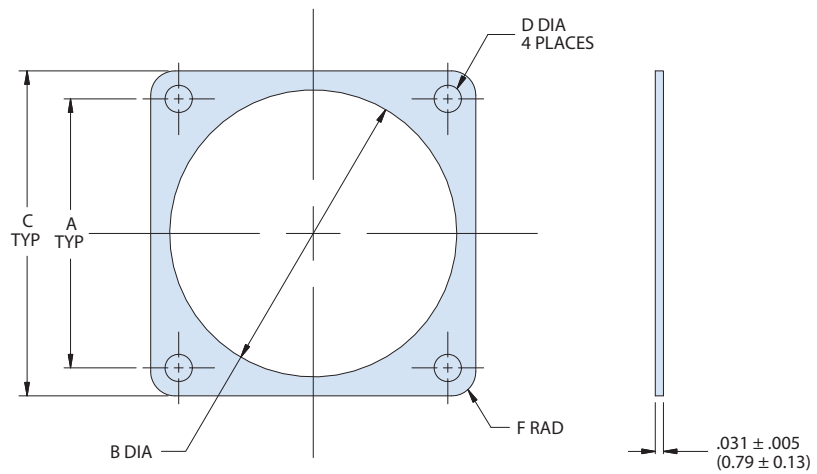

Shell Size MIL-C-28840	A ±.010	B DIA .016 .000	C .016 .000	D DIA ±.010	F Radius ±.010
11	0.750 (19.05)	0.750 (19.05)	1.023 (25.98)	0.120 (3.05)	0.141 (3.58)
13	0.843 (21.41)	0.875 (22.23)	1.138 (28.91)	0.120 (3.05)	0.141 (3.58)
15	0.968 (24.59)	1.062 (26.97)	1.258 (31.95)	0.120 (3.05)	0.141 (3.58)
23	1.281 (32.54)	1.500 (38.10)	1.718 (43.64)	0.120 (3.05)	0.188 (4.78)

MATERIAL AND FINISH	
Sym	Material Description
B	Silver plated aluminum filled fluorosilicone (IAW MIL-G-83528 Type D, color beige)
C	Silicone filled monel screen cloth or expanded metal (ref: metex 704-9311 or equiv)
F	Fluorosilicone
M	Rubber IAW ZZ-R-765 (superseded by a-a-59588), class 3, grade 30, embedded with monel wire IAW QQ-N-281
N	Neoprene
S	Silicone
V	Viton (fluorocarbon)