

440V*213 F/O Banding Backshell for Hybrid Copper/Fiber Applications

Series 806 Mil-Aero

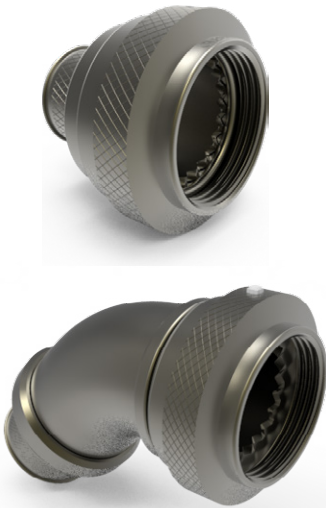

Series 44 environmental backshells with straight, swept 45° and 90° profiles are ideal for combo copper /fiber insert arrangements where EMI/RFI shielding and environmental sealing are needed. Anti-decoupling device for improved vibration resistance and detents to allow for axial positioning of backshell for improved cable routing.

HOW TO ORDER										
Sample Part Number	440V	S	213	MT	20	12	-8	B	P	T
Product	440V = Series 806 Backshell									
Angular Function	S = Straight N = 90° M = 45°									
Basic No.	213									
Finish Code	ME = Aluminum Alloy; Electroless Nickel NF = Aluminum Alloy; Cadmium/O.D. over Electroless Nickel (500 hr salt spray) MT = Aluminum Alloy; Electroless Nickel-PTFE ZL = Stainless Steel, Electro-deposited Nickel ZR = Aluminum Alloy; Zinc Nickel, Black over Electroless Nickel Z1 = Stainless Steel; Passivate									
Shell Size	See Dimensions table									
Dash Number	See Cable Entry / Back End / Boot P/N table									
Length	Length in 1/8 Inch Increments (8 = 1 inch); See Notes									
Band Option	B = Band K = Precoiled; omit if not required									
Shield Termination Finish	P = Polysulfide Plating Shield; See Notes									
Shrink Boot Material Options	See Shrink Boot Options table; See Notes									

NOTES

- For effective grounding, connector with conductive finish should be used.
- When Cable entry exceeds max. in Table I, Style II will be supplied. Dimensions F, G, H, J, K, L, M & N will not apply.
- Standard minimum length for style I is 0.75, for style II is 1.5 inches, for shorter length, consult factory, applies to SYM S, straight only.
- When polysulfide barrier is selected for plating shield termination, surface shall be free of cadmium.
- See 809-060 for additional shrink boot options.

MATERIAL / FINISH:

- Anti-decoupling device: corrosion resistant material
- O-rings: silicone/N.A.
- Shrink boot: see individual drawings
- Band: CRES/passivated

CABLE ENTRY / BACK END / BOOT P/N					
Dash No	X Dia	Y Dia	Z Dia	Shrink Boot T or H Ref	Shrink Boot w/Adhesive
02	0.125 (3.18)	0.165 (4.19)	0.266 (6.76)	809S060-1*U	809S060-1*
03	0.188 (4.78)	0.228 (5.79)	0.329 (8.36)	809S060-1*U	809S060-1*
04	0.250 (6.35)	0.290 (7.37)	0.391 (9.93)	809S060-2*U	809S060-2*
05	0.312 (7.92)	0.353 (8.97)	0.453 (11.51)	809S060-2*U	809S060-2*
06	0.375 (9.52)	0.415 (10.54)	0.516 (13.11)	809S060-2*U	809S060-2*
07	0.438 (11.13)	0.478 (12.14)	0.579 (14.71)	809S060-2*U	809S060-2*
08	0.500 (12.70)	0.540 (13.72)	0.641 (16.28)	809S060-3*U	809S060-3*
09	0.562 (14.27)	0.603 (15.32)	0.703 (17.86)	809S060-3*U	809S060-3*
10	0.625 (15.88)	0.665 (16.89)	0.766 (19.46)	809S060-3*U	809S060-3*
11	0.688 (17.48)	0.728 (18.49)	0.829 (21.06)	809S060-4*U	809S060-4*
12	0.750 (19.05)	0.800 (20.32)	0.891 (22.63)	809S060-4*U	809S060-4*
13	0.812 (20.62)	0.863 (21.92)	0.953 (24.21)	809S060-4*U	809S060-4*
14	0.875 (22.23)	0.925 (23.50)	1.016 (25.81)	809S060-5*U	809S060-5*
15	0.938 (23.83)	0.988 (25.10)	1.079 (27.41)	809S060-5*U	809S060-5*
16	1.000 (25.40)	1.050 (26.67)	1.141 (28.98)	809S060-5*U	809S060-5*
17	1.062 (26.97)	1.113 (28.27)	1.203 (30.56)	809S060-6*U	809S060-6*
18	1.125 (28.58)	1.175 (29.85)	1.266 (32.16)	809S060-6*U	809S060-6*
20	1.250 (31.75)	1.310 (33.27)	1.391 (35.33)	809S060-6*U	809S060-6*

440V*213 F/O Banding Backshell for Hybrid Copper/Fiber Applications

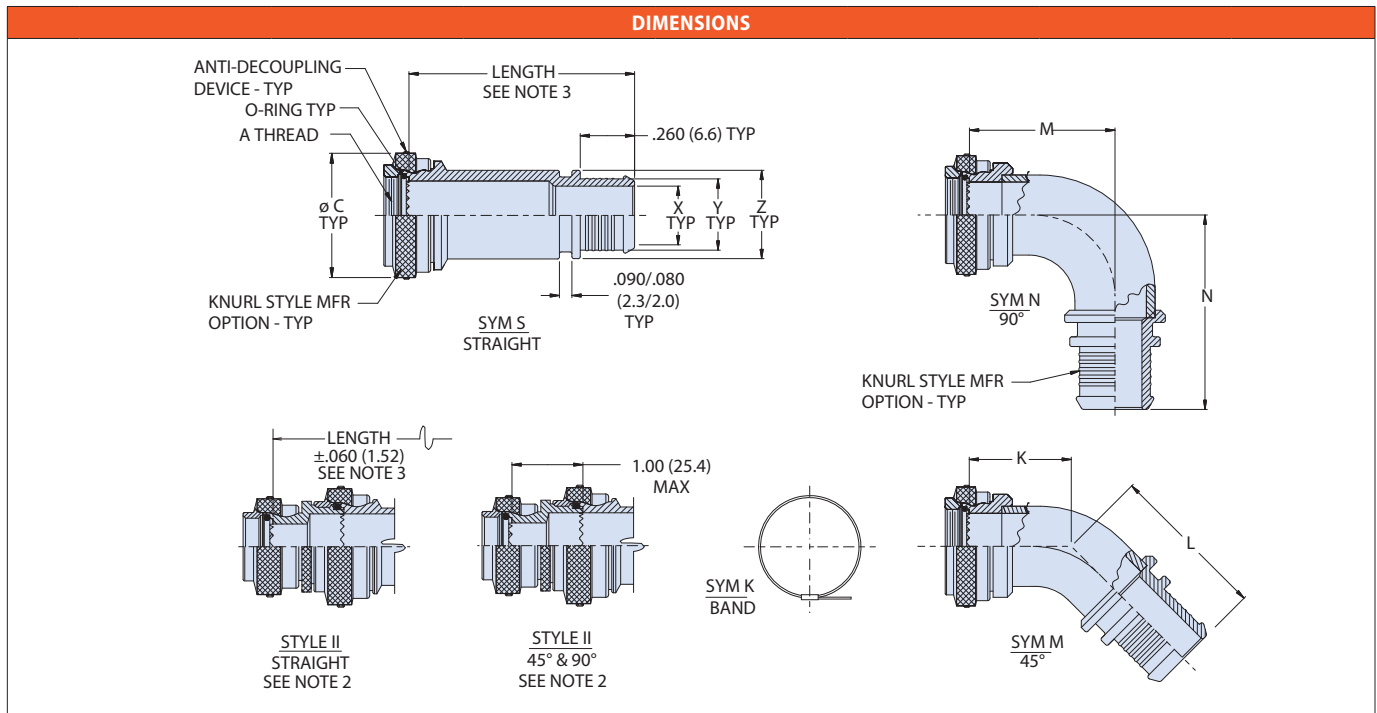

Shell Size	A Thread	Ø C Max	K Max	L Max	M Max	N Max	Max Dash No.
08	M10 x 1-6H	.692(17.58)	.790(20.07)	.965(24.51)	.940(23.88)	1.125(28.58)	04
09	M12 x 1-6H	.786(19.96)	.790(20.07)	.965(24.51)	.940(23.88)	1.125(28.58)	05
10	M14 x 1-6H	.883(22.43)	.790(20.07)	1.035(26.29)	.970(24.64)	1.225(31.12)	06
11	M15 x 1-6H	.911(23.14)	.790(20.07)	1.035(26.29)	.970(24.64)	1.225(31.12)	07
12	M17 x 1-6H	1.002(25.45)	.830(21.08)	1.115(28.32)	1.040(26.42)	1.325(33.66)	08
14	M19 x 1-6H	1.066(27.08)	.830(21.08)	1.115(28.32)	1.040(26.42)	1.325(33.66)	09
16	M22 x 1-6H	1.196(30.38)	.840(21.34)	1.185(30.10)	1.080(27.43)	1.425(36.20)	11

SHRINK BOOT OPTIONS	
Code	Description
T	Standard Fluid Resistant Elastomer With Adhesive Pre-Applied
TU	Standard Fluid Resistant Elastomer
N	Radiation Resistant Polyolefin, -50°C To 150°C (No Adhesive Option)
S	Low Outgassing Fluoropolymer; Use 779-001 As Adhesive Option (Not Included)
SU	Low-Outgassing Fluoropolymer, See Cable Entry / Back End / Boot P/N table; Omit For None