

## 806-013 Square Flange Receptacle

Series 806 Mil-Aero



**Tight-tolerance MIL-DTL-38999 Type Micro Miniature Square Flange Receptacle.** Made for use with high-density sizes 16 and 20HD snap-in, rear-release termini. Shallow-angle triple-start stub ACME threads prevent decoupling in high vibration, shock, and high-altitude aerospace and military/defense applications. Available with accessory threads or shield termination banding porch. Shell materials include Aluminum alloy and stainless steel. Keyed polarization for mis-mate protection. Available insert arrangements support from three to thirty-one singlemode and multimode termini. Tight contact pitch and reduced connector dimensions results in up to 50% size and weight savings compared to conventional aerospace-grade fiber optic connectors.

### SPECIFICATIONS

- Operating temperature: connector capable of -55°C to +200°C. Temperature rating for fiber applications limited by cable and epoxy used.
- Termination method: epoxy/polish
- Mating durability: 500 cycles
- Random vibration: 49.5 Grms, EIA-364-28 Test Condition V. Maximum optical discontinuity 0.5 dB, 50 microseconds.
- Mechanical shock: 300 G, TIA-455-14 Test Condition D. Maximum optical discontinuity 0.5 dB, 50 microseconds.

### CONNECTOR CONSTRUCTION

- Shell: aluminum or stainless steel
- Contacts: copper alloy, gold plating
- Wire grommet: blue fluorosilicone
- Dielectric inserts: high grade rigid dielectric
- Peripheral seal: blue fluorosilicone
- Contact retention clips: copper alloy
- Clinch nuts: stainless steel, passivated
- Retainer rings: stainless steel, passivated

### HOW TO ORDER

Sample Part Number	806-013	-ME	10-8	A	B	T	A
Product	806-013 = Panel Receptacle, Square Flange						
Shell Material and Finish	ME = Aluminum, Electroless Nickel MT = Aluminum, Ni/PTFE ZR = Aluminum, Black Zinc-Nickel NF = Aluminum, Olive Drab Cadmium Z1 = Stainless Steel, Passivated ZL = Stainless Steel, Electro-Deposited Nickel						
Arrangement Number (Shell Size - Insert Arr.)	See Arrangements table						
Contact Type	Connector supplied without termini A = Pin B = Socket order fiber optic termini separately						
Shell Style	M = Metric accessory threads B = Nano Band platform						
Mounting Hole Style	T = Thru holes C = Clinch nut, #4-40 (rear panel mounting)						
Polarizing Position	A B C D E F						

### SERIES 806 ARRANGEMENTS COMPATIBLE WITH 20HD FIBER OPTIC TERMINI

Mating face of pin connector. Socket numbering is reversed. Symbol ▼ indicates master key location.

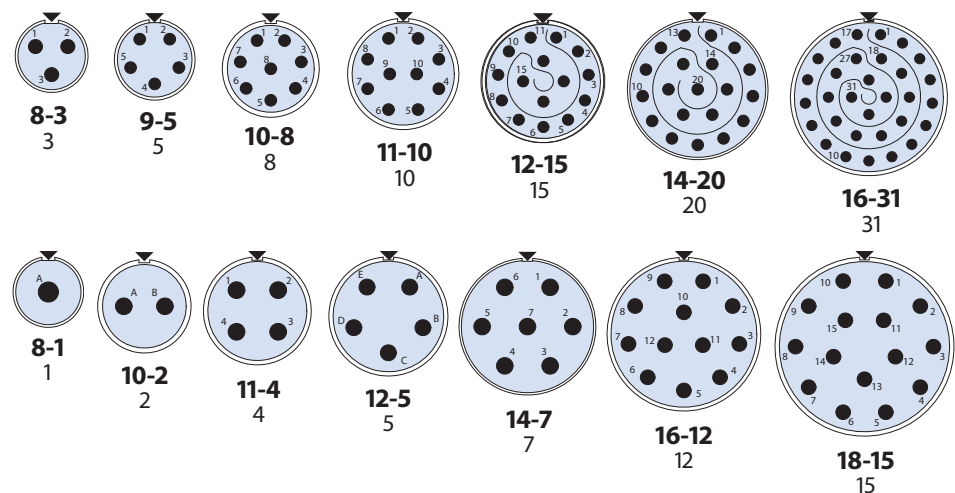

Consult factory for additional arrangements

## 806-013 Square Flange Receptacle

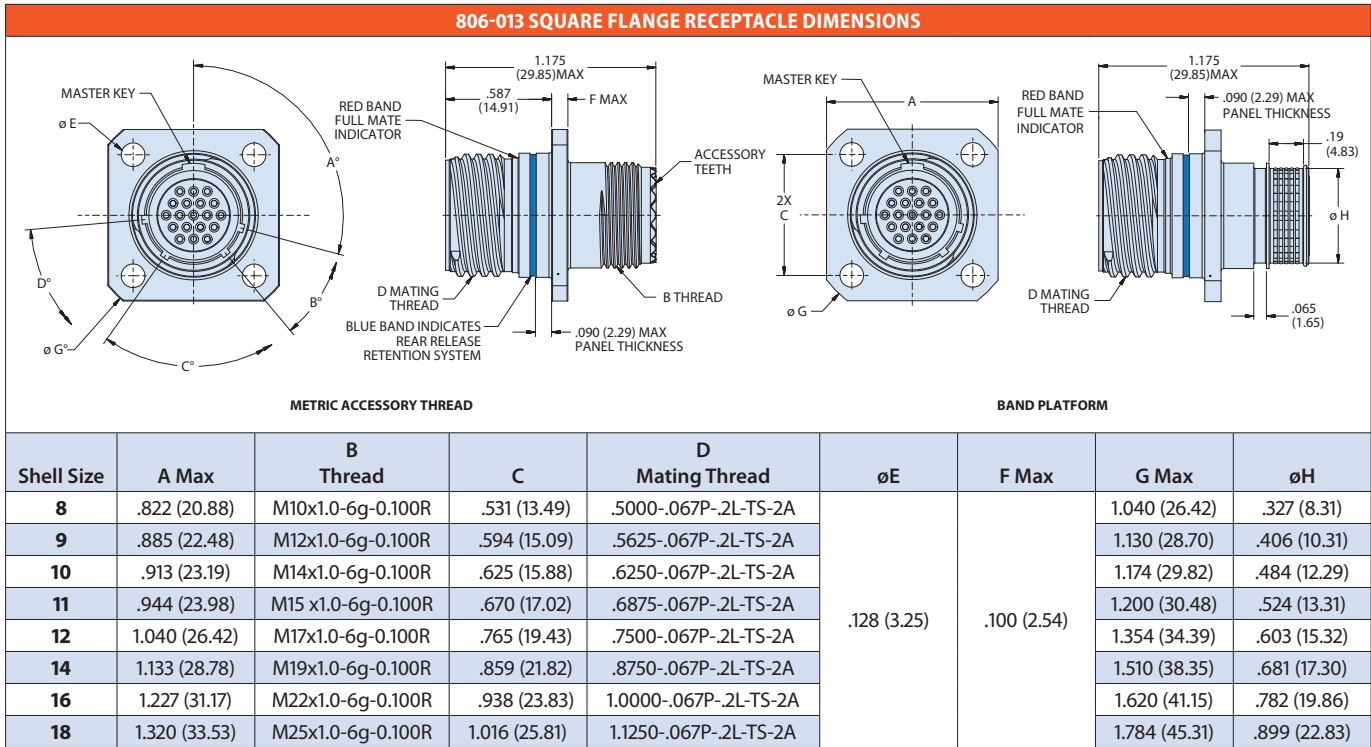

Higher density arrangements available. Consult factory for additional sizes.

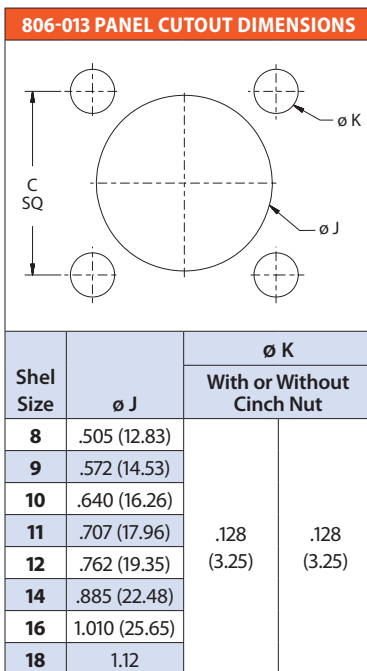

**HOW-TO-ORDER 20HD FIBER OPTIC TERMINI FOR SERIES 806 CONNECTORS**

Termini Type	Optical Fiber Type	Part Number	ØA Ferrule Hole	Fiber Size Core/Cladding
Pin	Singlemode	<a href="#">181-134-1255</a>	125.5 microns	9/125
Pin	Multimode	<a href="#">181-134-126</a>	126.0 microns	50/125, 62.5/125
Socket	Singlemode	<a href="#">181-135-1255</a>	125.5 microns	9/125
Socket	Multimode	<a href="#">181-135-126</a>	126.0 microns	50/125, 62.5/125

**HOW-TO-ORDER 16 FIBER OPTIC TERMINI FOR SERIES 806 CONNECTORS**

Termini Type	Optical Fiber Type	Part Number	ØA Ferrule Hole	Fiber Size Core/Cladding
Pin	Single Mode	<a href="#">181-145-125</a>	125.5 microns	9/125
Pin	Multi Mode	<a href="#">181-145-126</a>	126.0 microns	50/125, 62.5/125
Pin	Multi Mode	<a href="#">181-145-144</a>	144.0 microns	100/140
Socket	Single Mode	<a href="#">181-146-125</a>	125.5 microns	9/125
Socket	Multi Mode	<a href="#">181-146-126</a>	126.0 microns	50/125, 62.5/125
Socket	Multi Mode	<a href="#">181-146-144</a>	144.0 microns	100/140