

289T205

EMI/RFI, Split Top Entry Backshell, Banding for Series 280 Hiper-D Fiter Connectors

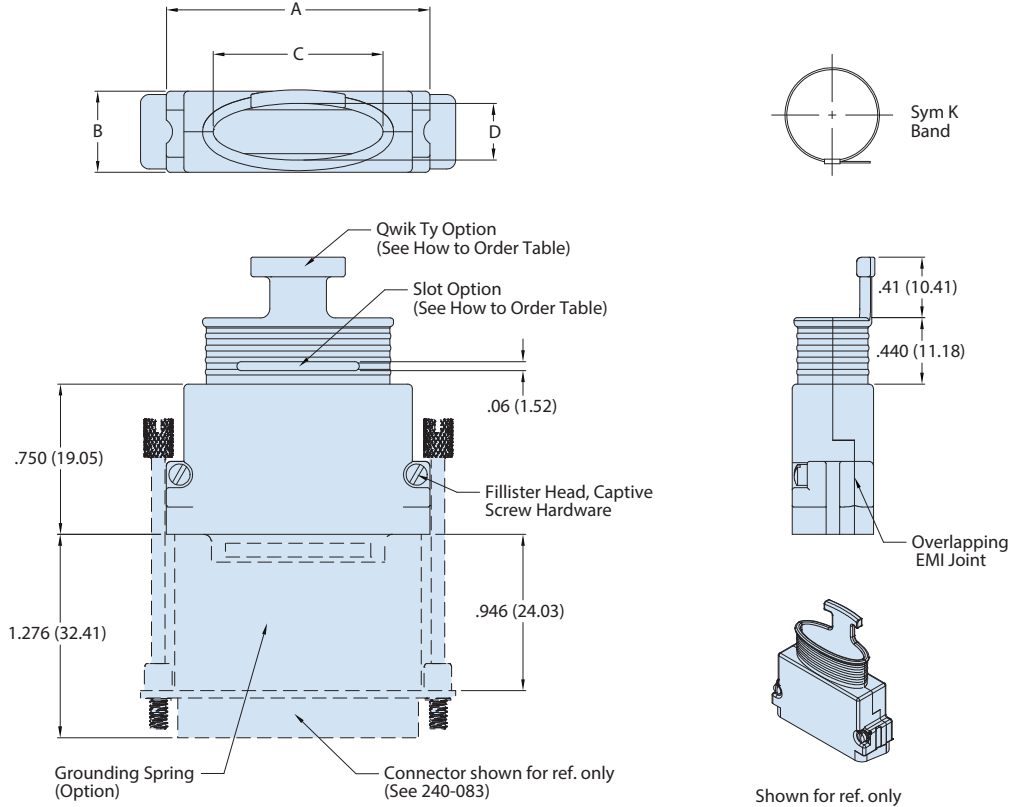

EMI/RFI BACKSHELL FOR SERIES 280 HIPER-D FILTER CONNECTORS



Shell	Entry Size A		Entry Size B		Entry Size C		Entry Size D		Entry Size E			
	A (Max)	B (Max)	C	D	C	D	C	D	C	D		
1	0.894 (22.71)	0.550 (13.97)	0.143 (3.63)	0.143 (3.63)	0.195 (4.95)	0.195 (4.95)	0.242 (6.15)	0.242 (6.15)	0.438 (11.13)	0.375 (9.53)	0.638 (16.21)	0.375 (9.53)
2	1.218 (30.94)	0.550 (13.97)	0.188 (4.78)	0.188 (4.78)	0.256 (6.50)	0.256 (6.50)	0.480 (12.19)	0.375 (9.53)	0.688 (17.48)	0.375 (9.53)	0.969 (24.61)	0.375 (9.53)
3	1.760 (44.70)	0.550 (13.97)	0.245 (6.22)	0.245 (6.22)	0.550 (13.97)	0.375 (9.53)	0.780 (19.81)	0.375 (9.53)	1.125 (28.58)	0.375 (9.53)	1.484 (37.69)	0.375 (9.53)
4	2.408 (61.16)	0.550 (13.97)	0.291 (7.39)	0.291 (7.39)	0.800 (20.32)	0.375 (9.53)	1.260 (32.00)	0.375 (9.53)	1.813 (46.05)	0.375 (9.53)	2.155 (54.74)	0.375 (9.53)
5	2.297 (58.34)	0.654 (16.61)	0.326 (8.28)	0.326 (8.28)	0.770 (19.56)	0.485 (12.32)	1.250 (31.75)	0.485 (12.32)	1.750 (44.45)	0.485 (12.32)	2.031 (51.59)	0.485 (12.32)
6	2.422 (61.52)	0.716 (18.19)	0.376 (9.55)	0.376 (9.55)	0.863 (21.92)	0.550 (13.97)	1.323 (33.60)	0.550 (13.97)	1.875 (47.63)	0.550 (13.97)	2.165 (54.99)	0.550 (13.97)

Dimensions in inches (millimeters) and are subject to change without notice.