



230-034
MIL-DTL-26482 Series II Type Hermetic
Bayonet Coupling Jam-Nut Mount Receptacle
MS3449 Type

Connector Style
034 = Single Hole Jam-Nut Mount Receptacle

Insert Arrangement
 Per MIL-STD-1669

Alternate Key Position
W, X, Y or Z
 (Omit for Normal))

230

- 034

FT

10

- 6

P

X

Series 230
MIL-DTL-26482
Type

Material/Finish
Z1 = Stainless Steel/Passivated
FT = C1215 Stainless Steel/Tin Plated
 (See Note 2)

Shell Size

Contact Type
P = Solder Cup, Pin Face
S = Solder Cup, Socket Face

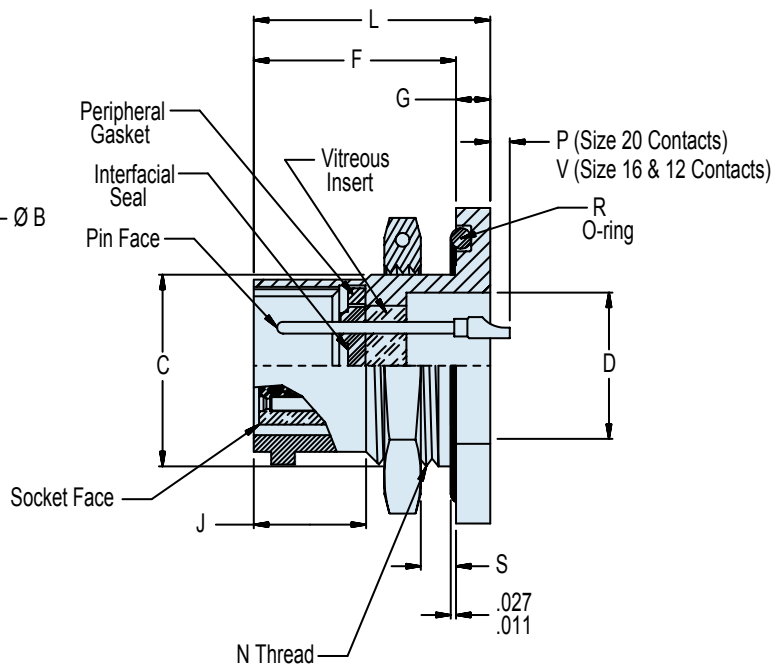
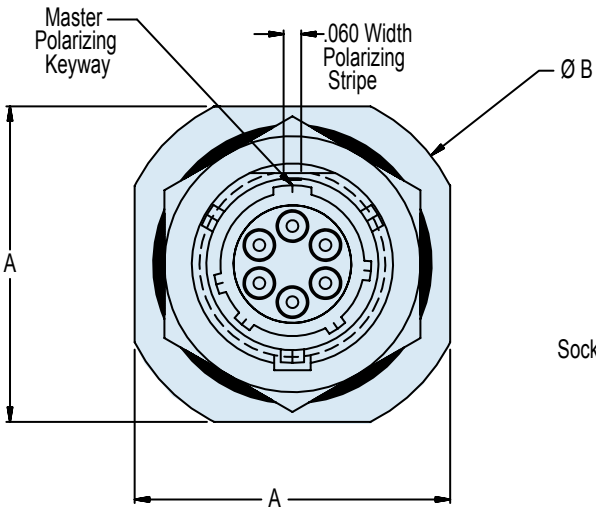
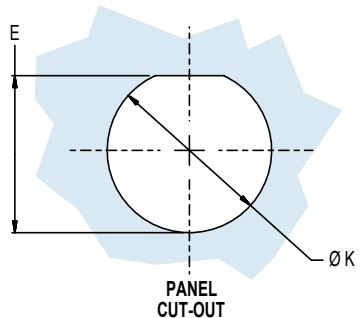

APPLICATION NOTES

- To be identified with manufacturer's name, part number and date code, space permitting.
- Material/Finish:
 Shell: Z1 - 304L stainless steel/passivate.
 FT - C1215 stainless steel/tin plated.
 Titanium and Inconel® available. Consult factory.
 Contacts - 52 Nickel alloy/gold plate.
 Bayonets - Stainless steel/passivate.
 Seals - Silicone elastomer/N.A.
 Insulation - Glass/N.A.
 Socket insulator - Rigid dielectric/N.A.
- Glenair 230-034 will mate with any QPL MIL-DTL-26482 Series II bayonet coupling plug of same size and insert polarization.
- Performance:
 Hermeticity - $<1 \times 10^{-7}$ cc/sec @ 1 atm differential.
 Dielectric withstanding voltage - Consult factory or MIL-STD-1669.
 Insulation resistance - 5000 megohms min @500VDC.
- Consult factory or MIL-STD-1669 for arrangement and insert position options.
- Metric Dimensions (mm) are indicated in parentheses.

230-034

MIL-DTL-26482 Series II Type Hermetic
Bayonet Coupling Jam-Nut Mount Receptacle
MS3449 Type



MIL-DTL-26482
Type

D

TABLE I: CONNECTOR AND CUT-OUT DIMENSIONS (Continued Below)

Shell Size	A Length + .000 - .031 (+0 -0.8)	B Dia + .000 - .031 (+0 -0.8) Across Flange Corner	C + .000 - .010 (+0 -0.3) Mounting Flat	D Dia Min	E Panel Flat Location	F Mounting Flange Location	G Mounting Flange Thickness	J To Thread Chamfer ± .010 (0.3)	K + .010 - .005 (+0.3 -0.1) Panel Mounting Hole
8	.954 (24.2)	1.078 (27.4)	.530 (13.5)	.403 (10.2)	.536 (13.6)	.707/.691 (18.0/17.6)	.113/.097 (2.9/2.5)	.368 (9.3)	.572 (14.5)
10	1.078 (27.4)	1.203 (30.6)	.655 (16.6)	.515 (13.1)	.661 (16.8)	.707/.691 (18.0/17.6)	.113/.097 (2.9/2.5)	.368 (9.3)	.697 (17.7)
12	1.266 (32.2)	1.391 (35.3)	.818 (20.8)	.630 (16.0)	.824 (20.9)	.707/.691 (18.0/17.6)	.113/.097 (2.9/2.5)	.368 (9.3)	.885 (22.5)
14	1.391 (35.3)	1.516 (38.5)	.942 (23.9)	.755 (19.2)	.948 (24.1)	.707/.691 (18.0/17.6)	.113/.097 (2.9/2.5)	.368 (9.3)	1.010 (25.7)
16	1.516 (38.5)	1.641 (41.7)	1.062 (27.0)	.880 (22.4)	1.072 (27.2)	.707/.691 (18.0/17.6)	.113/.097 (2.9/2.5)	.368 (9.3)	1.135 (28.8)
18	1.641 (41.7)	1.766 (44.9)	1.191 (30.3)	.980 (24.9)	1.197 (30.4)	.707/.691 (18.0/17.6)	.113/.097 (2.9/2.5)	.368 (9.3)	1.260 (32.0)
20	1.828 (46.4)	1.954 (49.6)	1.316 (33.4)	1.105 (28.1)	1.322 (33.6)	.772/.754 (19.6/19.2)	.148/.128 (3.8/3.3)	.368 (9.3)	1.385 (35.2)
22	1.954 (49.6)	2.078 (52.8)	1.441 (36.6)	1.230 (31.2)	1.447 (36.8)	.772/.754 (19.6/19.2)	.148/.128 (3.8/3.3)	.368 (9.3)	1.510 (38.4)
24	2.078 (52.8)	2.203 (56.0)	1.566 (39.8)	1.385 (35.2)	1.572 (39.9)	.803/.785 (20.4/19.9)	.148/.128 (3.8/3.3)	.395 (10.0)	1.635 (41.5)

TABLE I (Continued): CONNECTOR AND CUT-OUT DIMENSIONS

Shell Size	L Overall Length	N UNEF-2A Mounting Thread	P	R O-Ring Seal MS29513-	S Panel Thickness		V	Max. Weight (Lbs)
					Min	Max		
8	.820 (20.8)	.5625-24	.134/.074 (3.4/1.9)	16	.062 (1.6)	.187 (4.7)	.204/.144 (5.2/3.7)	.0430
10	.820 (20.8)	.6875-24	.134/.074 (3.4/1.9)	18	.062 (1.6)	.187 (4.7)	.204/.144 (5.2/3.7)	.0610
12	.820 (20.8)	.875-20	.134/.074 (3.4/1.9)	21	.062 (1.6)	.187 (4.7)	.204/.144 (5.2/3.7)	.0880
14	.820 (20.8)	1.000-20	.134/.074 (3.4/1.9)	23	.062 (1.6)	.187 (4.7)	.204/.144 (5.2/3.7)	.1100
16	.820 (20.8)	1.125-18	.134/.074 (3.4/1.9)	25	.062 (1.6)	.187 (4.7)	.204/.144 (5.2/3.7)	.1310
18	.820 (20.8)	1.250-18	.134/.074 (3.4/1.9)	27	.062 (1.6)	.187 (4.7)	.204/.144 (5.2/3.7)	.1720
20	.920 (23.4)	1.375-18	.099/.039 (2.5/1.0)	29	.062 (1.6)	.250 (6.4)	.169/.109 (4.3/2.8)	.2110
22	.920 (23.4)	1.500-18	.099/.039 (2.5/1.0)	30	.062 (1.6)	.250 (6.4)	.169/.109 (4.3/2.8)	.2420
24	.951 (24.2)	1.625-18	.099/.039 (2.5/0.1)	31	.062 (1.6)	.250 (6.4)	.169/.109 (4.3/2.8)	.2930

HERMETIC LEAK RATE MOD CODES

Designator	Required Leak Rate
-585A	1 x 10 ⁻¹⁰ cc Helium per second
-585B	1 x 10 ⁻⁹ cc Helium per second
-585C	1 x 10 ⁻⁸ cc Helium per second