

SERIES 28 HiPer-D® Accessories

Shorting Receptacle Assembly

289-055



Ordering Information				
Sample Part Number	289-055S	1H15	ME	S
Basic Part Number	289-055S Hiper-D Shorting Plug with Socket Contacts			
Shell Size/Insert Arrangements	See Contact Arrangement tables			
Shell Finish	ME - Electroless Nickel Over Aluminum MT - Nickel Fluorocarbon Over Aluminum Z1 - Passivated Stainless ZM - Electroless Nickel Over Stainless JF - Yellow Chromate Over Cadmium			
Hardware Options	N - None (Thru Hole) L - Low Profile Jackscrew S - Low Profile Jackpost		P - Female Jackpost K - Extended Jackscrew T - Extended Jackpost	

NOTES

1. Assembly identified with Glenair's name and part number, space permitting.
2. Material/finish
Receptacle assembly - see plating in p/n development
Hardware - CRES/passivated
3. See 280-019 for connector details.
4. HIPOT/DWV requirement: 5 ohms

Dimensions					
Shell Size	Insert Pattern	A Max		B Max	
		In.	mm	In.	mm
1	S9; H15	.894	22.71	.550	13.97
2	S15; H26	1.218	30.94	.550	13.97
3	S25; H44	1.760	44.70	.550	13.97
4	S37; H62	2.408	61.16	.550	13.97
5	S50; H78	2.297	58.34	.654	16.61
6	H104	2.422	61.52	.716	18.19

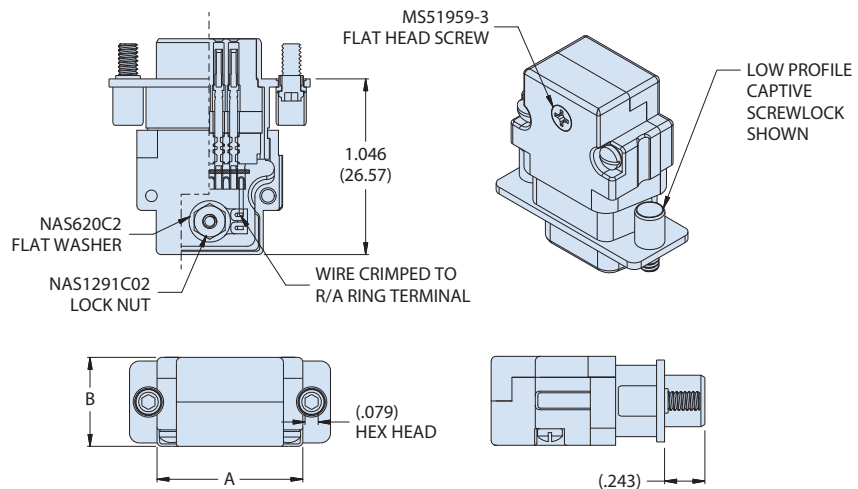

STANDARD AND HIGH DENSITY CONTACT ARRANGEMENTS (face view of pin connector)

