

Bridging the Gap

The purpose of a connector is easy to describe: connectors bridge gaps between individual pieces of electronic equipment to make assembly, repair and upgrades easier to accomplish. Instead of struggling with a Gordian knot of soldered circuits and spliced wiring, connectors enable technicians to make interconnections with ease and convenience.

Connectors bridge the gap between individual wires to provide contact between two conductive elements of an electronic system. The connection they make enables electrical current (or light waves in the case of fiber optics) to flow from one conductor to the next. Edward's Publishing's indispensable Encyclopedia of Connectors defines the connector thus: *"An electromechanical device which permits two or more circuit elements to be electrically and mechanically separated and reconnected at will without disturbing any other elements of the circuit. A connector performs no circuit function and should have no effect on the electrical performance of the device to which it is attached. If the connectors of a device were eliminated and*

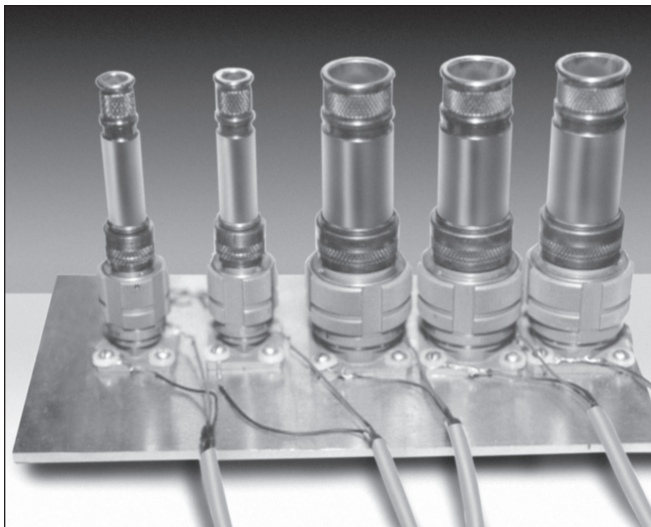

Connector testing is designed to simulate a lifetime of use over a short period of time. Environmental, mechanical and electrical tests are conducted to measure both the reliability of the connector and the system. The number-one criterion of reliability is a change in contact resistance.

the corresponding wires joined together, the circuit would not be affected."

When connectors are used to connect one set of wires to another, they are called wire-to-wire connectors. Wire-to-board connectors connect a wire to a Printed Circuit Board (PCB). And board-to-board connectors directly interconnect PCB's.

Connectors facilitate the manufacture and assembly of electronic products by enabling designers to treat each subassembly as a unique, modular unit. Interconnection can then be accomplished at the most convenient time and place in the production process. Connectors also facilitate the equipment repair process by allowing technicians to quickly and easily replace suspect components. Without opening black box cabinets and without introducing contaminants like solder and flux into the system, technicians can swap out suspect equipment and have a system back on line in a matter of minutes. Connectors also permit upgrades to electronic equipment without major disruptions to the overall system. Connectors give engineers the flexibility to integrate new products and components into existing systems simply by maintaining a consistent connector specification.

While there is great variety in the makeup and design of each type of connector, as a family they generally share a common set of design elements and component parts. In fact, in order to function as a separable interconnect device, a connector must house the following elements:

- **Contact Interface:** a mechanical means of joining the conductive contacts together under normal force
- **Contact Spring Members:** a means of generating the normal force required to maintain the electrical path between conductive contact elements
- **Contact Finish:** a means of protecting the contacts from corrosion, and for optimizing the lubricity and durability of the contact interface
- **Contact Housing:** a means of holding the contacts and spring members in place and maintaining their exact position and alignment.

Introduction to Military Standard Cylindrical Connectors



The contact housing also shields the contacts from the operating environment.

Connectors are selected with consideration to electrical, mechanical and environmental requirements. Electrical requirements include wire type and size, contact resistance, transfer impedance and current rating. Mechanical specifications, such as thermal shock, vibration and durability indicate how well a connector will perform under critical stress factors. Environmental requirements include moisture absorption, temperature resistance, corrosion and resistance to electromagnetic interference. Environmentally resistant connectors are required for interconnect systems which are subjected to fluids in combination with vibration, shock, thermal extremes and corrosion.

While the same basic connector design may be used for both signal and/or power distribution, power connectors use contacts designed specifically for the unique requirements of power distribution. This is due to the relatively higher current/voltage requirements of power applications and the temperature rise experienced by power connectors. A disk drive in a personal computer, for example, uses both signal and power connectors. The power connector bridges the circuit that drives the unit. The signal connector carries the digital data. While the signal and power contacts may be combined into a single connector housing, each contact type is uniquely suited for its role in transmitting either signal or power electrical energy.

The Military Standard Connector

The multi-contact electrical connector used in Air Force, Navy and other high-reliability applications is a critical subassembly within the wiring system. Military connectors find many diversified applications due to severe environments, mobility, and field repairability. The key attribute of such connectors is better reliability when compared to less expensive commercial connectors. The reliability of a system is essentially a measure of the failure rate

of its components. Connectors can fail due to plug dependent mechanisms, wear mechanisms or corrosion mechanisms. Total system life, power on-hours (POH) and system on/off cycles (number of times that a product powers on and off) are important factors determining system reliability. Military standard connectors (and their commercial equivalents) are chosen for their performance and reliability even in the most severe interconnect applications.

*"Power" connectors carry contacts
from size 4/0 to 16*

"Miniature" connectors from size 12 to 20

"High-density" connectors from size 20 to 22

"Microminiature" size 24.

The military standard connector is made up of two separate component assemblies known as the "plug and receptacle" which intermate to connect wires with pin and socket contacts. Connector families are defined in this high-reliability world by the military detail specifications which spell out the exact requirements for every aspect of the connector's design and performance. Connector families are distinguished by their coupling mechanisms, physical shape, contact types, environmental classes and termination methodologies.

Plug and receptacle connector pairs are available in various mounting configurations to accommodate different levels of interconnection and different application requirements. The most common configurations are for in-line (wire-to-wire) applications, or for various bulkhead, chassis and enclosure mountings. In general, connectors are available to accommodate any fixed mounting or in-line requirement.

Circular connectors are selected because of their compact, rugged design and their ability to effectively seal the connector from environmental hazards. Circular connectors may incorporate bayonet couplings, threaded couplings, ball detent couplings (push/pull), and/or breech lock couplings as their mechanism for locking the mated pairs together.

Rectangular connectors are selected to maximize the number of contacts possible in a restricted space. However, rectangulars are not as easily sealed against fluid damage and other environmental hazards. Spring style rack/panel couplings as well as standard jackscrew fasteners are both common coupling styles in rectangular connectors.

Both circulars and rectangulars can accommodate multiple contact types including power or high-voltage contacts, signal contacts, coaxial and triaxial contacts, or fiber-optic termini. High reliability contacts are usually made from gold plated, copper alloy material. Large diameter power contacts and solder type contacts may be either gold or silver plated copper alloy.

Crimp style contacts are preferred for all aerospace and other high-reliability applications (except those requiring a hermetic seal) due to their relative ease of assembly and maintenance. Solder type contacts are usually selected when cost is the primary consideration and repairability secondary. Solder type contacts are also used in hermetic connectors.

Installation of both crimp and solder type contact connectors requires unobstructed working room behind the connector. Rear release crimp contacts require additional working room to install the extraction tool to remove the contact. Another important design feature of crimp type contact connectors is the connector insert wire sealing grommet. The grommet provides moisture sealing around each individual wire.

The shell of a circular connector is a cylinder available in incremental sizes starting as small as .375" diameter up to 3.25" diameter and larger. The most common shell sizes are available in .0625" increments starting at shell size 8 (.50") to shell size 36 (2.25"). Shell size may be determined by multiplying the shell size number by .0625. Shell size 24, for example, has a 1.50" outside diameter ($24 \times .0625 = 1.50$ "). This nomenclature becomes significant, as backshells (accessories which attach onto the connector shell) must inter mate with the connector shell rear-end geometry. Connector and accessory manufacturers both use the term

"shell size" to designate the size of their respective products.

Making Sense of Connector Part Numbers

Military standard connectors are organized under specification series numbers: MIL-C-5015, MIL-C-38999 and so on. The specification series number identifies the master document which explains everything about the particular connector family. The actual part numbers of connector components are designed to call out the physical connector type and its dimensional attributes. For example, a MIL-C-5015 receptacle connector designed to be mounted on a box would have a part number such as MS3402DS28-21PY. The number can be dissected as follows:

The first 4 digits after the MS (Military Standard) designate the physical connector type, like so:

- 3400 - Wall mounted receptacle
- 3401 - In line receptacle
- 3402 - Box mount receptacle
- 3404 - Jam nut receptacle
- 3406 - Straight plug
- 3408 - 90° plug
- 3409 - 45° plug
- 3412 - Box mount receptacle with rear threads

The single character which follows indicates the connector service class:

- D - High Shock
- K - Firewall
- L - High Temperature
- W - General Purpose

The next character, S in our example, indicates the shell material; in this case stainless steel. The next two characters, 28 in our example, identify the shell size. The following pair of numbers, 21 in our example, identifies the contact arrangement. If this pair of characters is followed by an "S", it indicates female-style (socket) contacts. If they are followed by a "P", it indicates male contacts (Pin). The final character, Y in our example, indicates the choice of polarization keying.

That's all there is to it. While there are many part number complexities and nuances throughout the various MS connector families, they all follow the same basic approach to part number development.

Design Elements of Common Military Standard Connectors

The following pages recap standard circular military connector design features including illustrations of the individual design characteristics important to the accessory manufacturer when selecting or designing backshells.

MIL-C-5015 Connectors, Circular, MS3100 Series, Solder Types; Glenair Designator Code B

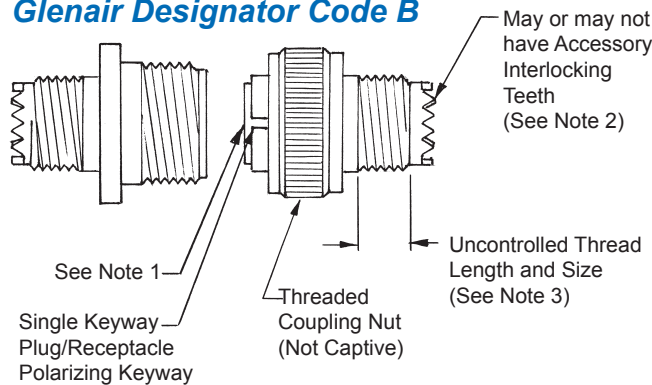

Design Features:

- Threaded coupling design.
- Fifteen shell sizes—Range 8 thru 48 (.500" to 3.000" diameter).
- Wide variety of contact sizes, standard density; 1 to 100 contacts.
- Conductive finish—Cadmium/Olive drab, 96-hour corrosion protection.

Notes:

1. Contacts may mate prior to connector shell mating.
2. Single keying may not always ensure shell polarizing.
3. Uncontrolled accessory interface.
4. Plug or receptacle may have pin or socket contacts.
5. Connector shell may strike pin contacts, thus power should always be on socket contacts.

MIL-C-5015 Connectors, Circular MS3400 (Front Release Contact) and MS3450 (Rear Release Contact) Series Crimp Type Contacts; Glenair Designator Code A

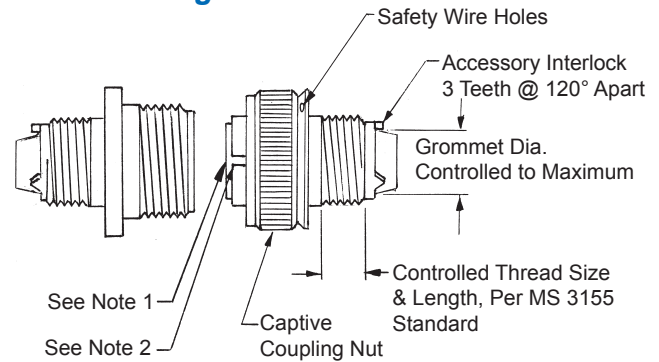

Design Features:

- Threaded coupling design, captive.
- Fifteen shell sizes—Range 8 thru 48 (.500" to 3.000" diameter).
- Wide variety of contact sizes, standard density; 1 to 100 contacts.
- Cadmium/Olive drab conductive finish, 500 hour salt spray; electroless-nickel options.

Notes:

1. Same interface features as MS3100 and MS3106; intermateable.
2. Single keying may not always ensure shell polarizing.

MIL-C-26482 Connectors, Circular MS3110 and MS3116 Series 1, Solder Contacts Glenair Designator Code D

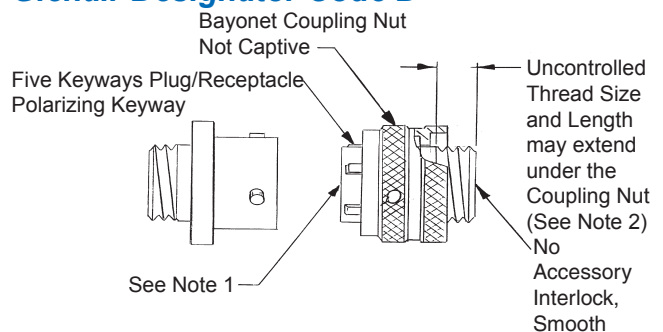

Design Features:

- Bayonet coupling design, quick disconnect.
- Ten shell sizes—Range 6 through 24 (.3750" to 1.500" diameter).
- 12, 16, and 20 gauge contacts, standard density, 3 to 61 contacts.
- Conductive and non-conductive finishes; Cadmium/Olive drab and anodic.

Notes:

1. Contacts may mate prior to connector shell mating.
2. Plug may have less than three threads.

MIL-C-26482 Connectors, Circular, MS3120 and MS3126 Series 1, Crimp Contacts, Front Release; Glenair Designator Code D

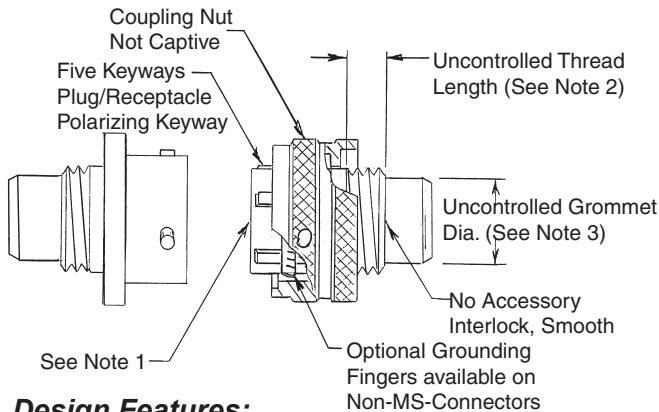

Design Features:

- Bayonet coupling design, quick disconnect.
- Eight shell sizes—Range 8 thru 24 (.500" to 1.500" diameter).
- 12, 16, 20, and 22 gauge contacts, standard density, 3 to 61 contacts.

Notes:

1. Contacts may mate prior to connector shell mating when grounding fingers not supplied.
2. Same limitations as MS3110 and MS3116 solder type connectors.
3. Uncontrolled wire seal grommet geometry; accessories properly mate.

MIL-C-26482 Connectors, Circular, MS3470 Series 2, Crimp Contacts, Rear Release; Glenair Designator Code A

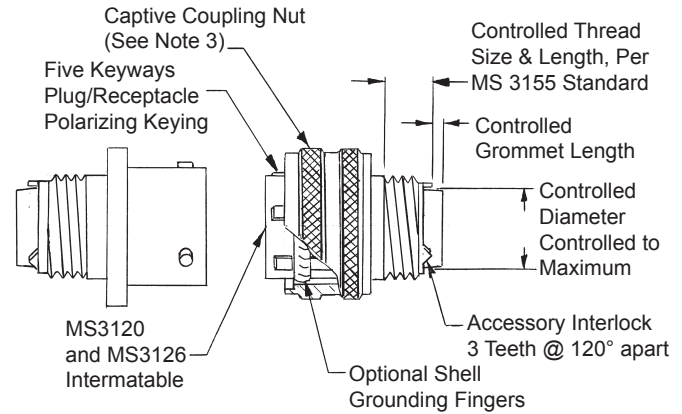

Design Features:

- Bayonet coupling design, quick disconnect.
- Nine shell sizes—8 through 24 (.500" to 1.500" dia)
- 12, 16, 20, and 22 gauge contacts, standard density, 3 to 61 contacts.

MIL-C-28840 Connectors, Circular, Front Release, Crimp Contacts Glenair Designator Code G

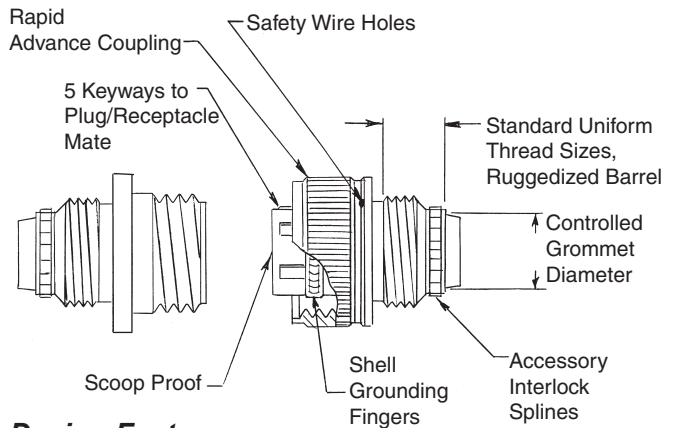

Design Features:

- Threaded coupling design, rapid advance, captive, scoop proof.
- Nine shell sizes—Range 11 through 33 (.500 to 2.000 diameter).
- 20 gauge high density contacts, 7 to 155.

Introduction to Military Standard Cylindrical Connectors



MIL-DTL-38999 Connectors, Series I Crimp Contacts, Rear Release; Glenair Designator Code F

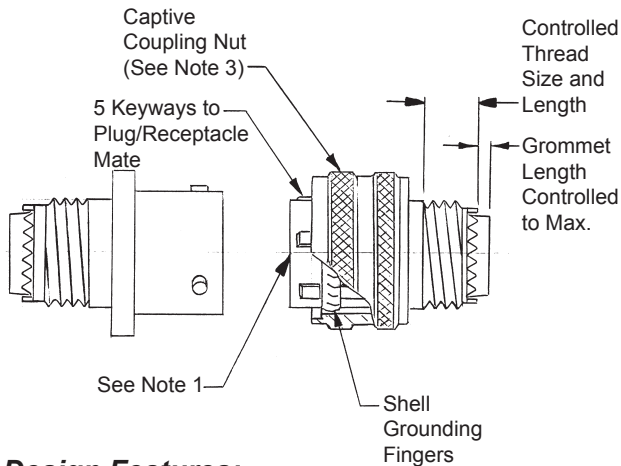

Design Features:

- Bayonet coupling design, quick disconnect.
- Nine shell sizes—Range 8 through 24 (.500" to 1.500" diameter).
- 12, 16, 20, and 22 gauge contacts, standard density and 22 gauge high density arrangements; 3 to 128 contacts.
- Scoop-proof shell design to prevent shell to contact problem.
- Controlled accessory interface per MIL-DTL-38999, figure 11.
- Cork and bottle primary insert interface seal and shell environmental seal, fuel resistant silicone elastomers.
- Conductive and non-conductive finishes; electroless nickel, Cadmium/Olive drab 500 hour salt spray, and anodic.

Notes:

1. Long barrel design to prevent shell striking contacts.
2. Serrated accessory interlocking tooth design may prevent reliable moisture seal or EMI bond to accessories.
3. Bayonet coupling may not perform under severe conditions with large diameter cable and backshell.

MIL-DTL-38999 Connectors, Series II Crimp Type Contacts, Rear Release; Glenair Designator Code F

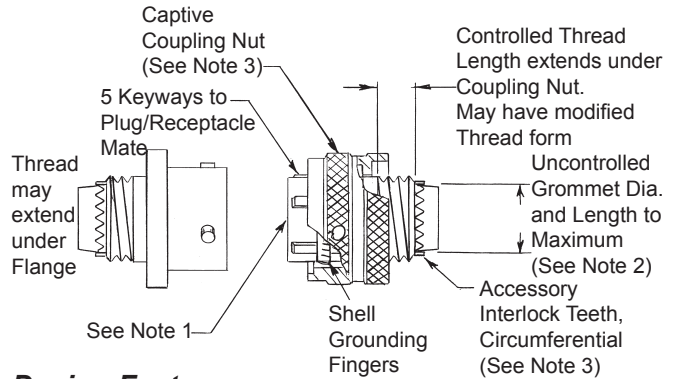

Design Features:

- Bayonet coupling design, quick disconnect, captive.
- Nine shell sizes—Range 8 through 24 (.500" to 1.500" diameter).
- 16, 20, and 22 gauge contacts, standard density and 22 gauge high density arrangements; 3 to 128 contacts.
- Shell ground available on MS and commercial part numbers.
- Controlled accessory interface per MIL-DTL-38999 figure II.
- Cork and bottle primary interface and shell environmental seals, fluid resistant silicone elastomers.
- Conductive and non-conductive finishes; electroless nickel, Cadmium/Olive drab, 500-hour salt spray, and anodic.
- Short barrel construction for minimum envelope.

Notes:

1. Very short barrel, shell may strike pin contacts.
2. Wire seal grommet controlled to maximum condition only, over compression will cause contact splaying.
3. Same limitations as D38999 Series I.

MIL-DTL-38999 Connectors, Series III Circular, Crimp Contacts Rear Release; Glenair Code H

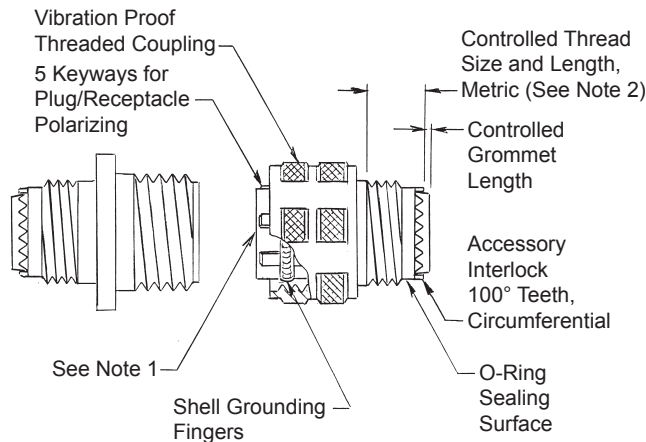

Design Features:

- Threaded coupling design, rapid advance, self-locking.
- Nine shell sizes—Range 9 through 25 (.500" to 1.500" diameter).
- 12, 16, 20, and 22 gauge contacts, standard density and 22 gauge high density arrangements; 3 to 128 contacts.
- 16 gauge fiber-optic insert arrangement.
- Scoop-proof shell design to prevent shell to contact problem.
- Controlled accessory interface with metric threads.
- Diaphragm contact seal interface and shell environmental seal, fluid resistant fluorosilicone elastomers.
- Conductive and non-conductive finishes; Cadmium/Olive drab 500 hour salt spray, electroless nickel, anodic and stainless steel.
- Conductive composite shell, cadmium/olive drab over electroless nickel, and electroless nickel, 2000 hour salt spray.

Notes:

1. Same barrel features as MIL-DTL-38999 Series I, except metric threads.
2. 100 percent scoop proof, positive shell mating.

MIL-DTL-38999 Connectors, Series IV Circular, Crimp Contacts Rear Release; Glenair Code H

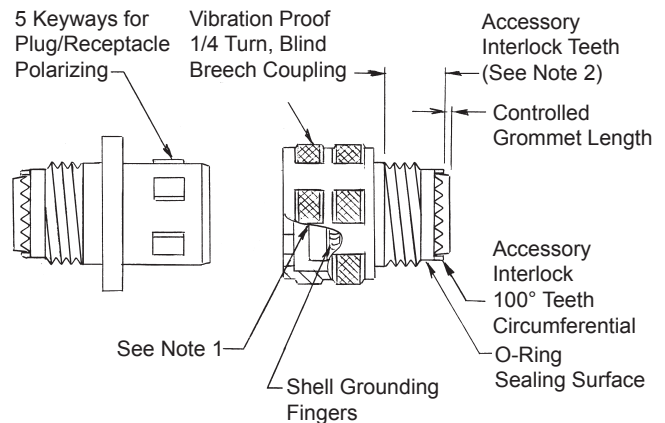

Design Features:

- Breech lock coupling design, rapid advance, self-locking.
- Eight shell sizes—Range 11 through 25 (.500" to 1.500" diameter).
- 12, 16, 20, and 22 gauge contacts, standard density and 22 gauge high density arrangements; 3 to 128 contacts.
- 16 gauge fiber-optic insert arrangements.
- Scoop proof shell design to prevent shell to contact problems.
- Controlled accessory interface with metric threads.
- Ruggedized construction for shipboard service.
- Cork and bottle primary interface and shell environmental seals, fluid resistant fluorosilicone elastomers.
- Conductive and non-conductive finishes; Cadmium/Olive drab 500 hour salt spray, electroless nickel, anodic, and stainless steel.

Notes:

1. 100 percent scoop proof, positive shell mating.
2. Same accessory interlock teeth as MIL-DTL-38999, Series III.
3. Same O-ring seal features as MIL-DTL-38999, Series III.