

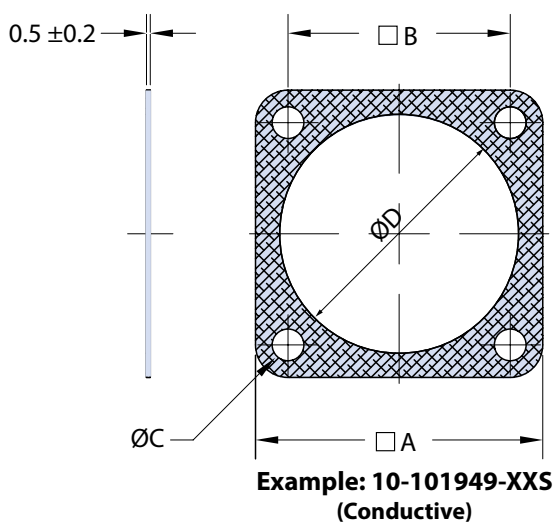

# 10-101949 and 10-101949-S Square Flange Panel Mount Receptacle Sealing Gaskets

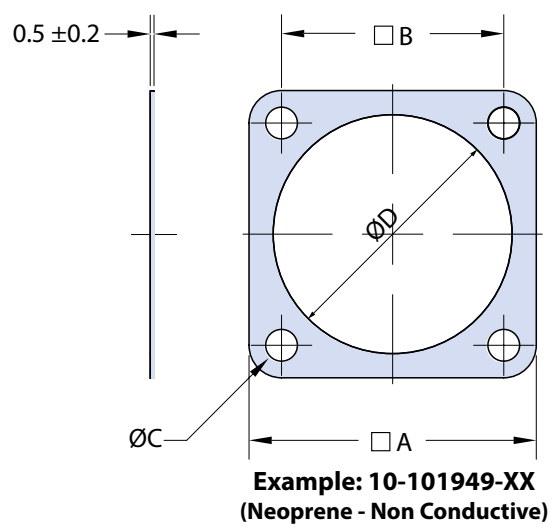
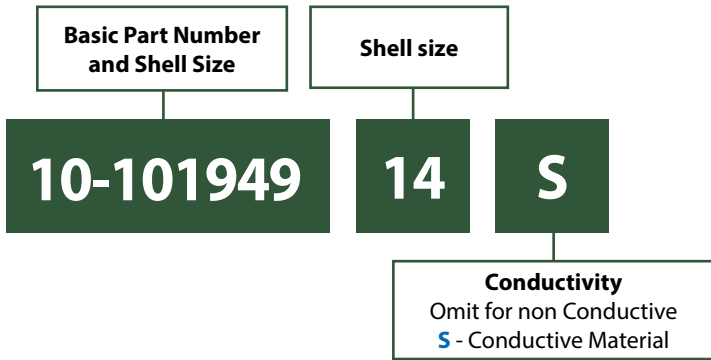

**OBSOLETE  
FOR NEW DESIGNS!  
Please contact the factory**

**TABLE I (NON CONDUCTIVE)**

GLENAIR P/N	Shell size	□ A Max	□ B ±0.3	ØC min.	ØD +0.1 / 0
10-101949-8	8	22.7	15.10	3.1	12.7
10-101949-10	10	25.8	18.30	3.1	15.9
10-101949-12	12	28.2	20.60	3.1	19.0
10-101949-14	14	30.6	23.00	3.1	22.2
10-101949-16	16	33.0	24.60	3.1	25.4
10-101949-18	18	35.4	27.00	3.1	28.6
10-101949-20	20	38.5	29.40	3.1	31.7
10-101949-22	22	41.7	31.80	3.1	34.9
10-101949-24	24	44.9	34.90	4.2	38.1

**TABLE II (CONDUCTIVE)**

GLENAIR P/N	Shell size	□ A Max	□ B ±0.3	ØC min.	ØD +0.1 / 0
10-101949-8S	8	20.6	15.10	3.3	12.7
10-101949-10S	10	23.8	18.25	3.3	15.9
10-101949-12S	12	26.2	20.60	3.3	19.1
10-101949-14S	14	28.6	23.00	3.3	22.3
10-101949-16S	16	31.0	24.60	3.3	25.5
10-101949-18S	18	33.3	27.00	3.3	28.6
10-101949-20S	20	36.5	29.35	3.3	31.8
10-101949-22S	22	39.7	31.75	3.3	35.0
10-101949-24S	24	42.9	34.90	4.0	38.2