

SERIES 800 UN THREAD MATING Mighty Mouse Connectors and Cables



PC Tail or Solder Cup Hermetic Receptacles Shell Size 5 and 6



Compact, Rugged Series 800 glass-to-metal seal hermetic receptacles feature stainless steel shells. Contacts are gold-plated iron alloy. UN mating thread. Available with male pin contacts (contact Glenair for hermetic connectors with female socket contacts). 100% tested to meet 1×10^{-7} ccHe/sec @ 1 atm helium leak rate. Contacts are factory-installed and are non-removable. Terminate to wires with solder cup versions, or choose PC tail versions for thru-hole soldering to rigid or flexible circuit boards. Available in all contact and insert arrangements between size 5 and 12.

How To Order						
Sample Part Number	800-013	-02	Z1	6-7	P	N
Series	800-013 Hermetic Receptacle					
Shell Style (See Table I)	02 = Square Flange 03 = Solder Mount 07 = Jam-Nut					
Shell Material and Finish	Z1 = Stainless Steel / Passivated ZL = Stainless Steel / Nickel Plated					
Shell Size - Insert Arrangement	See Contact Arrangements page D-4					
Contact Type	P = Pin, Solder Cup S = Socket, Solder Cup C = Pin, PC Tail D = Socket, PC Tail					
Shell Keyway Position	N = Normal X = Pos. X Y = Pos. Y Z = Pos. Z					

Table II: Contact Dimensions	
Contact Size	Ø EE
23	.022/.018
20	.028/.024
16	.064/.060
12	.096/.092

Table III: CC and DD Dia.		
Shell Size	Ø CC O.D.	Ø DD O.D.
5	.290 (7.37)	.197 (5.00)
6	.330 (8.38)	.256 (6.50)
7	.380 (9.65)	.325 (8.25)
8	.450 (11.43)	.390 (9.91)
9	.500 (12.70)	.452 (11.48)
10	.575 (14.60)	.520 (13.21)
12	.660 (16.76)	.610 (15.49)

DWV Rating	
Contact Size	Test Voltage
23	750 Vac
20 HD	1000 Vac
20, 16, 12, 8	1800 Vac

Table I: Shell Style		
-02 Square Flange	-03 Solder Mount	-07 Jam-Nut

SOLDER MOUNT RECEPTACLE - SHELL STYLE 03 - SHELL SIZE 5 AND 6

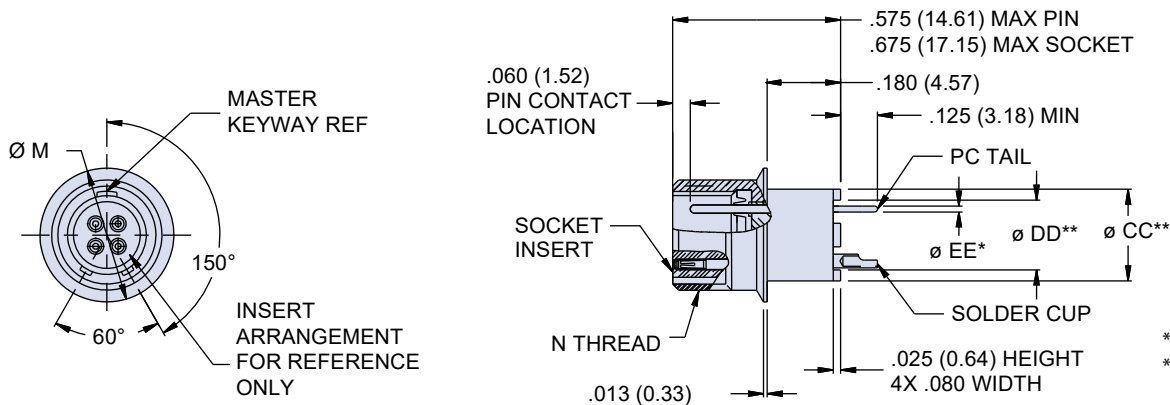

* See Table II
** See Table III

SERIES 800 UN THREAD MATING

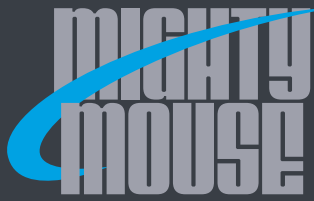

SERIES 800 UN THREAD MATING

Mighty Mouse Connectors and Cables



PC Tail or Solder Cup Hermetic Receptacles
Shell Size 5 and 6

SQUARE FLANGE MOUNT RECEPTACLE - SHELL STYLE 02 - SHELL SIZE 5 AND 6

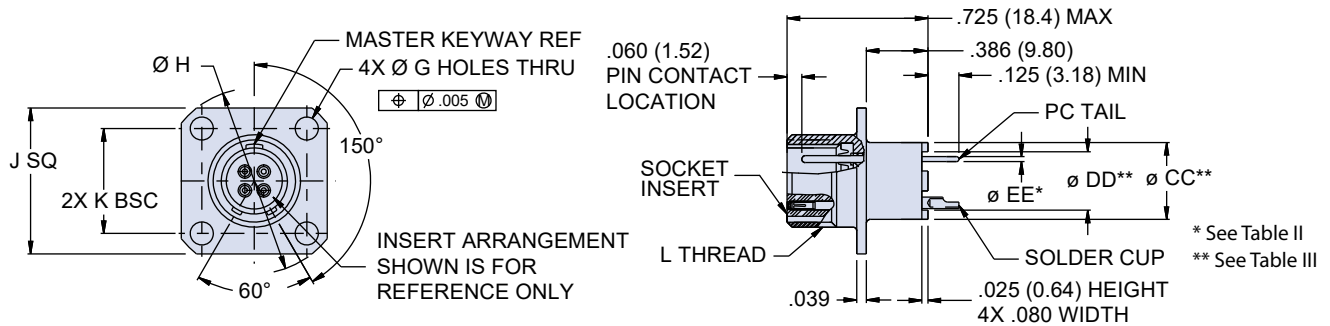

JAM-NUT MOUNT RECEPTACLE - SHELL STYLE 07 - SHELL SIZE 5 AND 6

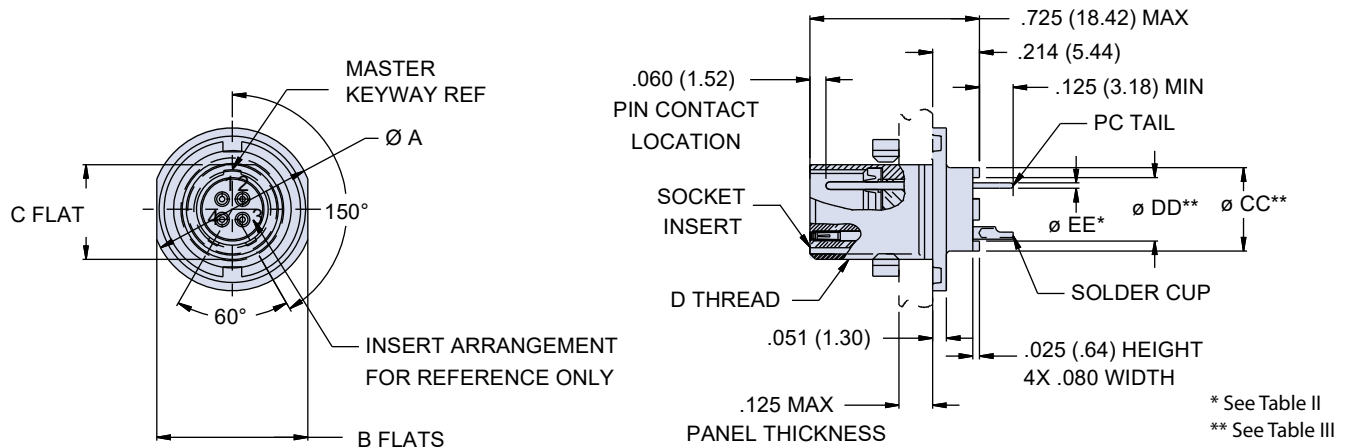

Solder Mount Dimensions		
Shell Size	Ø M	N Thread
5	.400 (10.16)	.3125-28 UN-2A
6	.455 (11.56)	.3750-28 UN-2A

Square Flange Dimension					
Shell Size	Ø G	Ø H	J Sq	K BSC	L Thread
5	.096 (2.44)	.680 (17.27)	.527 (13.39)	.363 (9.22)	.3125-28 UN-2A
6	.091 (2.31)	.750 (19.05)	.588 (14.94)	.423 (10.74)	.3750-28 UN-2A

Jam-Nut Dimensions				
Shell Size	Ø A	B Flat	C Flat	D Thread
5	.541 (13.74)	.500 (12.70)	.285 (7.24)	.3125-28 UN-2A
6	.610 (15.49)	.562 (14.27)	.352 (8.94)	.3750-28 UN-2A

Master Key Positions, Shell Size 5-6	
	Position
N	150°
X	140°
Y	130°
Z	120°

NOTES

- See page D-7 for panel cut-out dimensions
- Hemeticity is less than 1×10^{-7} at one atmosphere, not for use in liquid environments
- Material / finish:
 - Shell: CRES / see How to Order Table
 - Jam-nut: CRES 303; see How to Order Table
 - Contact: alloy 52 gold plate
 - Socket: fluorosilicone / N.A.
 - Seals: fluorosilicone / N.A.
 - Insulator, hermetic: glass / N.A.
 - Insulator, socket: high-grade dielectric / N.A.

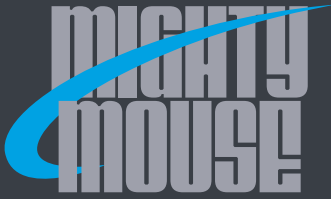

PC Tail or Solder Cup Hermetic Receptacles
Shell Sizes 7-12

SOLDER MOUNT, FRONT PANEL MOUNT RECEPTACLE - SHELL STYLE 03 - SHELL SIZE 7 THRU 12

* See Table II
** See Table III

INSERT ARRANGEMENT
SHOWN IS FOR
REFERENCE ONLY

Master Key Positions, Shell Size 7-12

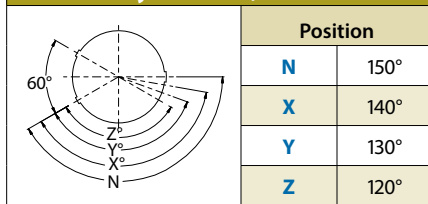

Solder Mount Dimensions

Shell Size	Ø A	B Thread
7	.520 (13.21)	.4375-28 UNEF-2A
8	.650 (16.51)	.5000-32 UN-2A
9	.764 (19.41)	.5625-32 UN-2A
10	.775 (19.68)	.6250-32 UN-2A
12	.858 (21.79)	.7500-28 UN-2A

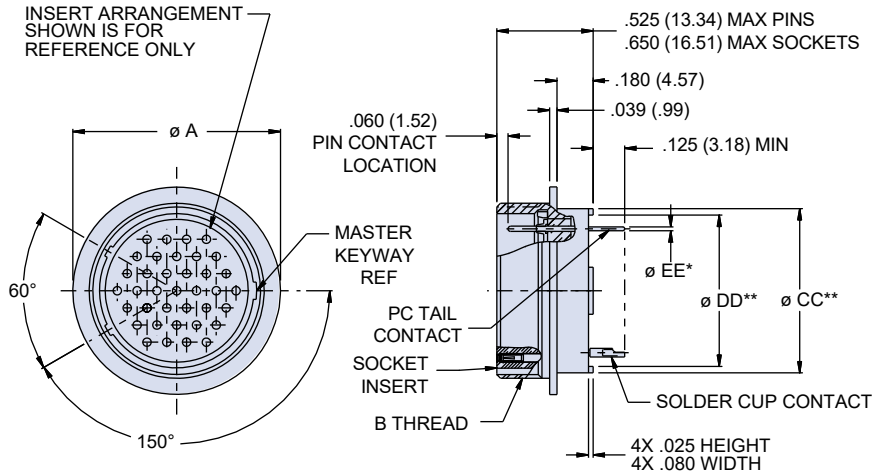

NOTES

- Material / finish:
 - Shell: CRES / see How to Order Table
 - Contacts: alloy 52 / gold plate
 - Sockets: copper alloy / gold plate
 - Seals: fluorosilicone / N.A.
- Insulator, hermetic: fused glass / N.A.
- Insulator, socket: high-grade dielectric / N.A.

SQUARE FLANGE, FRONT PANEL MOUNT RECEPTACLE - SHELL STYLE 02 - SHELL SIZE 7 THRU 12

NOTES

- See page D-7 for panel cut-out dimensions
- Material / finish:
 - Shell: CRES / see How to Order Table
 - Contacts: alloy 52 / gold plate
 - Socket: copper alloy / gold plate
 - Seals: fluorosilicone / N.A.
 - Insulator, hermetic: fused glass / N.A.
 - Insulator, socket: high-grade dielectric / N.A.

* See Table II
** See Table III

INSERT ARRANGEMENT
FOR REFERENCE ONLY

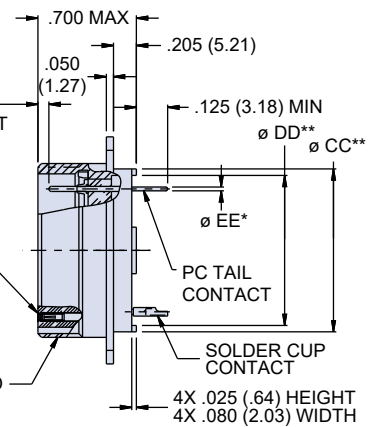
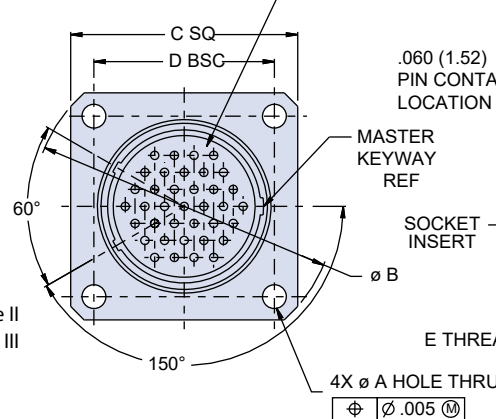

Master Key Positions, Shell Size 7-12

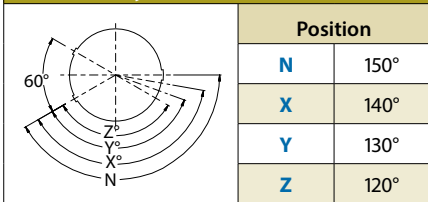

Square Flange Mount Dimensions

Shell Size	Ø A	Ø B	C SQ	D BSC	E Thread
7	.096 (2.44)	.830 (21.08)	.650 (16.51)	.483 (12.27)	.4375-28 UNEF-2A
8	.091 (2.31)	.935 (23.75)	.710 (18.03)	.542 (13.77)	.5000-32 UN-2A
9	.130 (3.30)	1.250 (31.75)	.938 (23.83)	.719 (18.26)	.5625-32 UN-2A
10	.126 (3.20)	1.250 (31.75)	.938 (23.83)	.719 (18.26)	.6250-32 UN-2A
12		1.375 (34.92)	1.031 (26.19)	.812 (20.62)	.7500-28 UN-2A

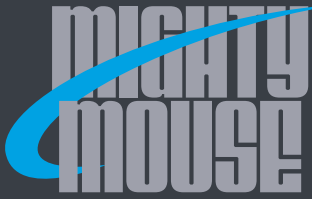

SERIES 800 UN THREAD MATING Mighty Mouse Connectors and Cables



PC Tail or Solder Cup Hermetic Receptacles Shell Sizes 7-12

JAM-NUT, REAR PANEL MOUNT RECEPTACLE - SHELL STYLE 07 - SHELL SIZE 7 THRU 12

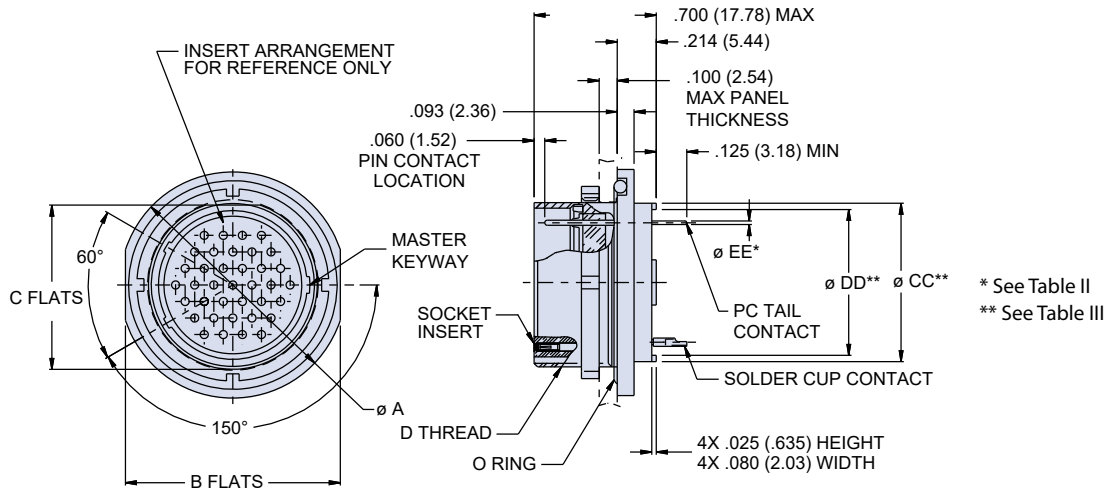

Keyway Positions, Shell Size 7-12		
	Position	
	N	150°
	X	140°
	Y	130°
Z	120°	

Jam-Nut Dimensions				
Shell Size	Ø A	B Flats	C Flats	D Thread
7	.670 (17.02)	.635 (16.13)	.411 (10.44)	.4375-28 UNEF-2A
8	.775 (19.68)	.735 (18.67)	.473 (12.01)	.5000-32 UN-2A
9	.875 (22.23)	.806 (20.47)	.530 (13.46)	.5625-32 UN-2A
10	.980 (24.89)	.940 (23.88)	.604 (15.34)	.6250-32 UN-2A
12	1.062 (26.97)	.986 (25.04)	.712 (18.08)	.7500-28 UN-2A

NOTES

- See page D-7 for panel cut-out dimensions
- Material / finish:
 - Shell, jam-nut: CRES / see How to Order Table
 - Contacts: alloy 52 / gold plate
 - Sockets: copper alloy / gold plate
 - Seals: fluorosilicone / N.A.
 - Insulator, hermetic: fused glass / N.A.
 - Insulator, socket: high-grade dielectric / N.A.