

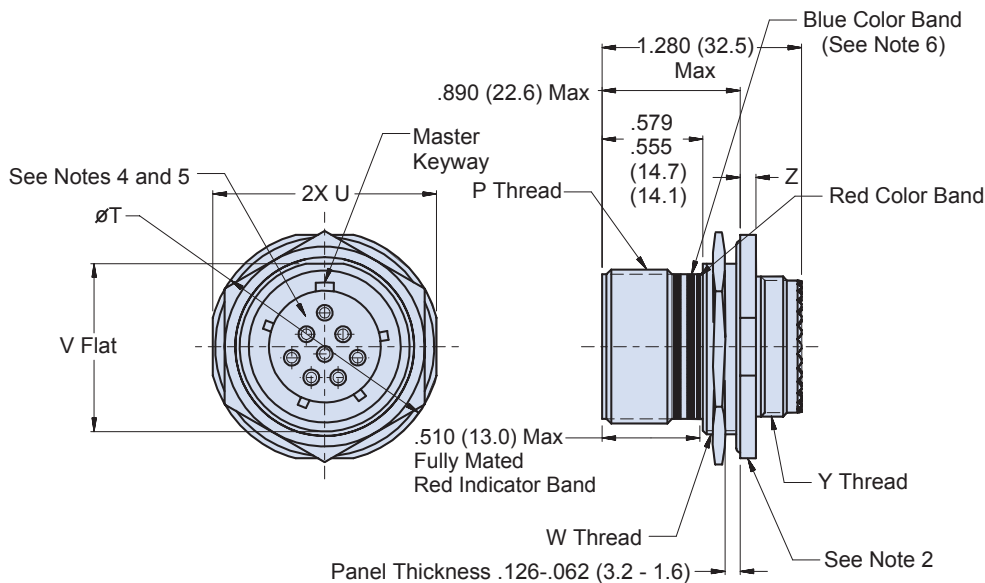

233-105-07 MIL-DTL-38999 Series III Type Jam Nut Environmental Receptacle Connector

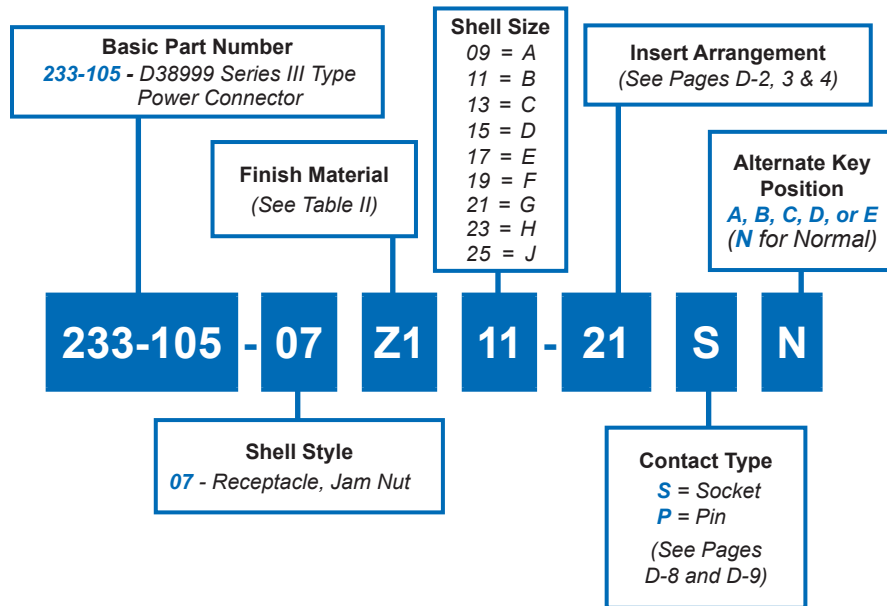

Consult factory for available insert arrangements.

APPLICATION NOTES

1. Material/ Finishes:
Shells, Jam Nut - See Table II
(Composite Jam Nut No Plating Required).
Insulators- High Grade Rigid Dielectric/ N.A
Seals- Fluorosilicone/ N.A.
2. Assembly to be identified with Glenair's name, part number and date code space permitting.
3. Modified major diameter 1.252-1.257 (31.80-31.95).
4. Insert arrangement in accordance with MIL-STD-1560.
5. Insert arrangement shown is for reference only.
6. Blue Color Band indicates rear release retention system.
7. Metric dimensions (mm) are in parentheses.

233-105-07
MIL-DTL-38999 Series III Type
Jam Nut Environmental Receptacle Connector



TABLE II: FINISH			
SYM	MATERIAL	FINISH	MIL SYM
ME	Aluminum	Electroless Nickel	F
NF		Cadmium O.D. Over Electroless Nickel	W
ZN		Zinc Ni, Olive Drab	Z
ZE		Zinc Ni, No Chromate	
ZR		Zinc Ni, Black (Tri-Valent CR)	
AL		Pure-Dense Electro-Deposited Aluminum	P
MT		Ni-PTFE 1000 Hour Grey™	T
XM	Composite	Electroless Nickel	M
XMT		Ni-PTFE 1000 Hour Grey™	
XO		No Finish	
XW		Cadmium O.D. over Electroless Nickel	J
Z1	Stainless Steel	Passivate	
ZC		Zinc Colbalt	
ZL		Electro-Deposited Nickel	
ZW		Cadmium O.D. over Nickel	
AB	Marine Bronze	None (Clean Only)	

*Consult Factory for Additional Plating Options

D

TABLE III: SHELL SIZE								
Shell Size Code	Shell Size	P Thread	T Dia	U	V	W Thread	Y Thread	Z
A	09	.6250-.1P-.3L-TS-2A	1.200 (30.5) 1.178 (29.9)	1.078 (27.4) 1.048 (26.6)	.654 (16.6) .645 (16.4)	M17 x 1.0-6g 0.100R	M12 x 1.0-6g 0.100R	.122 (3.1) .083 (2.1)
B	11	.7500-.1P-.3L-TS-2A	1.386 (35.2) 1.362 (34.6)	1.268 (32.2) 1.236 (31.4)	.755 (19.2) .745 (18.9)	M20 x 1.0-6g 0.100R	M15 x 1.0-6g 0.100R	
C	13	.8750-.1P-.3L-TS-2A	1.512 (38.4) 1.488 (37.8)	1.390 (35.3) 1.358 (34.5)	.942 (23.9) .932 (23.7)	M25 x 1.0-6g 0.100R	M18 x 1.0-6g 0.100R	
D	15	1.0000-.1P-.3L-TS-2A	1.638 (41.6) 1.614 (41.0)	1.516 (38.5) 1.484 (37.7)	1.066 (27.1) 1.056 (26.8)	M28 x 1.0-6g 0.100R	M22 x 1.0-6g 0.100R	
E	17	1.1875-.1P-.3L-TS-2A	1.764 (44.8) 1.740 (44.2)	1.642 (41.7) 1.610 (40.9)	1.191 (30.3) 1.181 (30.0)	M32 x 1.0-6g 0.100R*	M25 x 1.0-6g 0.100R	
F	19	1.2500-.1P-.3L-TS-2A	1.949 (49.5) 1.925 (48.9)	1.827 (46.4) 1.795 (45.6)	1.316 (33.4) 1.306 (33.2)	M35 x 1.0-6g 0.100R	M28 x 1.0-6g 0.100R	.153 (3.9) .114 (2.9)
G	21	1.3750-.1P-.3L-TS-2A	2.075 (52.7) 2.051 (52.1)	1.953 (49.6) 1.921 (48.8)	1.441 (36.6) 1.431 (36.3)	M38 x 1.0-6g 0.100R	M31 x 1.0-6g 0.100R	
H	23	1.5000-.1P-.3L-TS-2A	2.201 (55.9) 2.177 (55.3)	2.079 (52.8) 2.047 (52.0)	1.566 (39.8) 1.556 (39.5)	M41 x 1.0-6g 0.100R	M34 x 1.0-6g 0.100R	
J	25	1.6250-.1P-.3L-TS-2A	2.323 (59.0) 2.299 (58.4)	2.205 (56.0) 2.173 (55.2)	1.691 (43.0) 1.681 (42.7)	M44 x 1.0-6g 0.100R	M37 x 1.0-6g 0.100R	

*See Note 3