

Glenair Connector Savers protect expensive connector contacts with Glenair Connector Savers. Once installed this device will reduce wear on vital contacts and eliminate downtime due to fouled or damaged connectors.

How to Order				
Sample Part Number	891-016	-31	US	P1
Series	891-016 Dual Row Connector Saver			
Number of Contacts	9, 15, 21, 25, 31, 37, 41, 51, 65, 69, 85			
Connector Type	US - Plug to Socket One Piece Shell			
Hardware	P1 - Permanently Installed Jackscrew/Jackpost Male Thread on Plug Side S1 = Permanently Installed Jackscrew/Jackpost Male Thread on Receptacle Side			

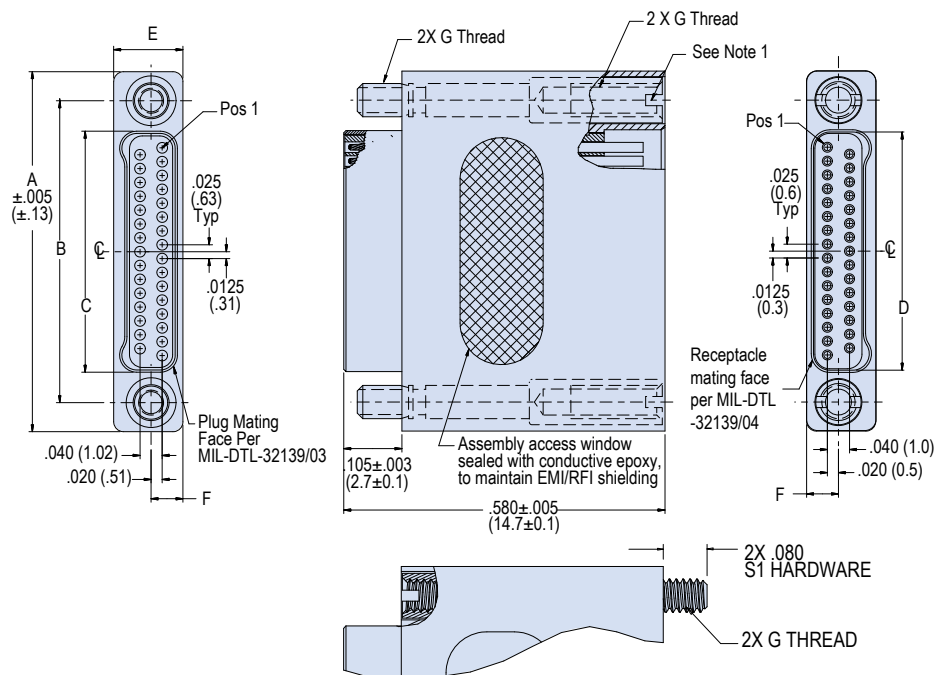

NOTES

- Jack post head has a slot drive. Use slotted blade miniature screwdriver. #0-80 Blade tip .018" Thick x .080" Wide. #2-56 Blade tip .025" Thick x .105" wide. Jackscrew/jackpost recommended torque: #0-80 0.5 - 1.0 in-lbs, #2-56 0.75 - 1.5 in-lbs.
- Aluminum shell, electroless nickel plated

Dimensions

Size	A	B Bsc	C Bsc	D Bsc	E	F	G Thrd
9	.375 (9.5)	.270 (6.9)	.160 (4.1)	.163 (4.1)	.125 (3.18)	.0575 (1.46)	#0-80 UNF
15	.450 (11.4)	.345 (8.8)	.235 (6.0)	.238 (6.0)	.125 (3.18)	.0575 (1.46)	#0-80 UNF
21	.525 (13.3)	.420 (10.7)	.310 (7.9)	.313 (8.0)	.125 (3.18)	.0575 (1.46)	#0-80 UNF
25	.575 (14.6)	.470 (11.9)	.360 (9.1)	.363 (9.2)	.125 (3.18)	.0575 (1.46)	#0-80 UNF
31	.650 (16.5)	.545 (13.8)	.435 (11.0)	.438 (11.1)	.125 (3.18)	.0575 (1.46)	#0-80 UNF
37	.725 (18.4)	.620 (15.7)	.510 (13.0)	.513 (13.0)	.125 (3.18)	.0575 (1.46)	#0-80 UNF
41	.775 (19.7)	.670 (17.0)	.560 (14.2)	.563 (14.3)	.125 (3.18)	.0575 (1.46)	#0-80 UNF
51	.900 (22.9)	.795 (20.2)	.685 (17.4)	.688 (17.5)	.125 (3.18)	.0575 (1.46)	#0-80 UNF
65	1.075 (27.3)	.970 (24.6)	.860 (21.8)	.863 (21.9)	.125 (3.18)	.0575 (1.46)	#0-80 UNF
69	1.125 (28.6)	1.020 (25.9)	.910 (23.1)	.913 (23.2)	.125 (3.18)	.0575 (1.46)	#0-80 UNF
85	1.377 (34.98)	1.246 (31.65)	1.110 (28.19)	1.113 (28.27)	.150 (3.81)	.0700 (1.78)	#2-56 UNC