

# SERIES 89 NANOMINIATURE Single and Dual Row Nano Strip Connectors

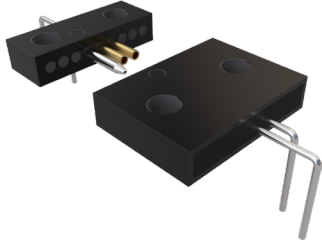

## 890-048 Single Row, Plastic Shell, Nano Strip, Right-Angle Mount Thru-Hole PCB Connector

SINGLE AND DUAL ROW NANO STRIP CONNECTORS



**Nano Strip Right-Angle Thru-Hole PCB Connectors** feature gold alloy TwistPin contacts. Contacts are precision-crimped to uninsulated wire. These nanominiature strip connectors offer premium performance and reliability for demanding applications. Pre-Tinned PC Tail are coated with Sn63Pb37 or Sn60Pb40 Tin-Lead for excellent solderability

**TwistPin Contact System** assures premium performance in demanding environments. The gold alloy contacts will stand up to years of exposure without corrosion.

**Typical Applications** include UAVs, satellites, missile systems and geophysical instruments.

### HOW TO ORDER

Sample Part Number	890-048	-9	P	-BRT	1	-P1	MH
Series	890-048 = single row, plastic shell Nano Strip RA thru-hole PCB connector						
Number of Cavities	1 thru 40 = total number of cavities including cavities used for guide pins and disabled cavities used for mounting holes, if any. See Table I						
Contact Type	P = pin (plug)      S = socket (receptacle)						
Termination Type	BRT = board right-angle thru-hole						
PC Tail Length	1 = .110		2 = .172		3 = .140; wire length in inches		
Optional Guide Pin	Omit for no guide pin (guide pin in receptacle, accepts guide pin in plug) P1 = guide pin or accepts guide pin in position 1 (add 1 cavity to number of active contacts) PB = guide pin or accepts guide pin in 1 and last position (add 2 cavities to number of active contacts) PX = guide pin or accepts guide pin in position specified by "X" (add 1 cavity to number of active contacts)						
Optional Mounting Holes	Omit for no mounting holes      MH = mounting holes (add 6 cavities to number of active contacts)						

OPTIONAL MOUNTING HOLES CLEARANCE FOR 1MM SCREW

OPTIONAL GUIDE PIN

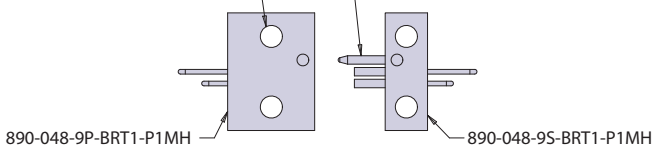

NUMBER OF CAVITIES EXAMPLE	
2	ACTIVE CONTACTS
+1	P1 GUIDE PIN
+6	MOUNTING HOLES
9	TOTAL

### NANO STRIP PCB LAYOUT

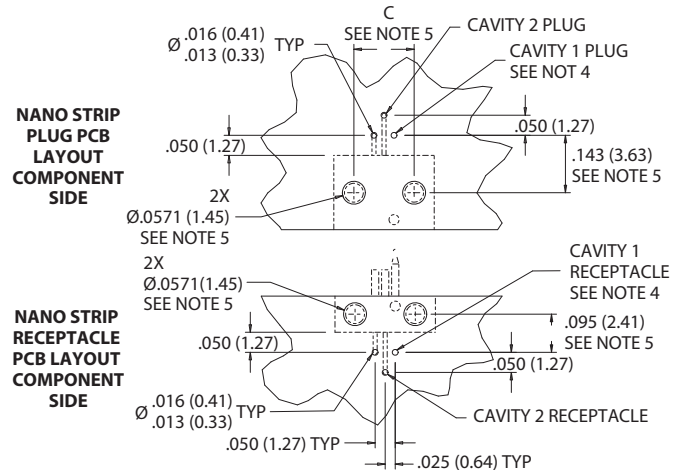

### PERFORMANCE SPECIFICATIONS

**Contact Spacing:** .025" (0.64) contact centers  
**Current Rating:** 1 AMP maximum tested per EIA-364-70  
**DWV:** 250 VAC RMS sea level, 100 VAC RMS 70,000 feet per EIA-364 Procedure 20  
**Insulation Resistance:** 5000 Megohms minimum test voltage 100 VDC, per EIA-364 Procedure 21  
**Operating Temperature:** -55° C. to +125° C.

**Contact Resistance:** 71 millivolt drop maximum, 1 AMP current, any catalog supported wire type  
**Corrosion Resistance:** 48 hour salt spray IAW EIA-364-26, Condition B  
**Humidity:** 240 hours, IAW EIA-364-31, Test Condition B  
**Contact Engaging/Separation Force:** 5 ounce maximum, 0.4 ounce minimum  
**Thermal Vacuum Outgassing:** Total mass loss (TML) 1.0% max., volatile condensable material (VCM) 0.1% max. IAW ASTM E595

# SERIES 89 NANOMINIATURE Single and Dual Row Nano Strip Connectors



## 890-048 Single Row, Plastic Shell, Nano Strip, Right-Angle Mount Thru-Hole PCB Connector

**TABLE I: DIMENSIONS**

Plug											
Receptacle											
Number Cavities	A	C See Note 5	Number Cavities	A	C See Note 5	Number Cavities	A	Optional C See Note 5	Number Cavities	A	C See Note 5
1	0.050 (1.27)	N/A	11	0.300 (7.62)	0.200 (5.08)	21	0.550 (13.97)	0.450 (11.43)	31	0.800 (20.32)	0.700 (17.78)
2	0.075 (1.91)	N/A	12	0.325 (8.26)	0.225 (5.72)	22	0.575 (14.61)	0.475 (12.07)	32	0.825 (20.96)	0.725 (18.42)
3	0.100 (2.54)	N/A	13	0.350 (8.89)	0.250 (6.35)	23	0.600 (15.24)	0.500 (12.70)	33	0.850 (21.59)	0.750 (19.05)
4	0.125 (3.18)	N/A	14	0.375 (9.53)	0.275 (6.99)	24	0.625 (15.88)	0.525 (13.34)	34	0.875 (22.23)	0.775 (19.69)
5	0.150 (3.81)	N/A	15	0.400 (10.16)	0.300 (7.62)	25	0.650 (16.51)	0.550 (13.97)	35	0.900 (22.86)	0.800 (20.32)
6	0.175 (4.45)	N/A	16	0.425 (10.80)	0.325 (8.26)	26	0.675 (17.15)	0.575 (14.61)	36	0.925 (23.50)	0.825 (20.96)
7	0.200 (5.08)	0.100 (2.54)	17	0.450 (11.43)	0.350 (8.89)	27	0.700 (17.78)	0.600 (15.24)	37	0.950 (24.13)	0.850 (21.59)
8	0.225 (5.72)	0.125 (3.18)	18	0.475 (12.07)	0.375 (9.53)	28	0.725 (18.42)	0.625 (15.88)	38	0.975 (24.77)	0.875 (22.23)
9	0.250 (6.35)	0.150 (3.81)	19	0.500 (12.70)	0.400 (10.16)	29	0.750 (19.05)	0.650 (16.51)	39	1.000 (25.40)	0.900 (22.86)
10	0.275 (6.99)	0.175 (4.45)	20	0.525 (13.34)	0.425 (10.80)	30	0.775 (19.69)	0.675 (17.15)	40	1.025 (26.04)	0.925 (23.50)

SINGLE AND DUAL ROW NANO STRIP CONNECTORS

### NOTES

- Material and Finishes:
  - Shell: polyphenylene sulfide (PPS)
  - Contacts: gold alloy / unplated
  - Pre-tinned PC tails: Coated with Sn63Pb37 or Sn60Pb40 tin-lead solder
  - Optional guide pin: stainless steel, passivated
- Inspect and test IAW MIL-DTL-32139 where applicable
- Strip shell may have a half cavity on either end or each end
- Pads corresponding to guide pin(s) or cavities that accept guide pin(s) can be omitted
- Only applies if ordered with optional mounting holes