

SERIES 89 NANOMINIATURE Threaded and Breakaway Nano Circulars

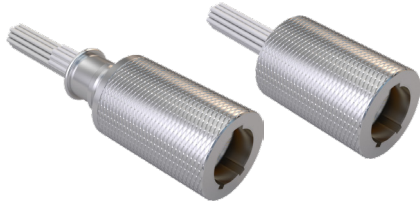

892-004 Inline, Breakaway Receptacle with Insulated Wire

THREADED AND BREAKAWAY NANO CIRCULARS



Glenair Inline Breakaway Receptacle Connectors feature gold alloy contacts, offering premium performance and reliability for demanding applications. Available with or without backshell. Backshell option available with shrink boot or overmolding. Choose Aluminum or Stainless Steel Shells in 6 layouts from 4 to 55 contacts. These connectors are intermateable with Nano Miniature plug connectors 892-007.

HOW TO ORDER	
Sample Part Number	892 -004 -02 1-7 N A2 -0 A 7 -12
Series	892 = Nano Circular with Insulated Wire
Shell Style	004 = In-Line Breakaway Receptacle
Accessory	01 = No Backshell 02 = With Backshell 03 = Overmolded 04 = Shrink Boot
Shell Size/Contact Arrangement	1-4 = Shell Size 1 with 4 contacts 3-37 = Shell Size 3 with 37 contacts 1-7 = Shell Size 1 with 7 contacts 4-44 = Shell Size 4 with 44 contacts 2-19 = Shell Size 2 with 19 contacts 4-55 = Shell Size 4 with 55 contacts See Receptacle Mating Face View and Contact Layout Table
Polarization	N = Normal A = Alternate
Shell Material/Finish	A2 = Aluminum/Electroless Nickel S1 = Stainless Steel/Zinc Cobalt (Black) A5 = Aluminum/Gold Over Nickel S2 = Stainless Steel/Passivated
Wire Gauge	0 = 30 AWG (Wire Types A, B, C, E, and F) 2 = 32 AWG (Wire Type B Only)
Wire Type	A = Ultra lightweight XLETFE insulation, silver coated ultra high strength copper B = Extruded PTFE insulation, silver coated copper NEMA HP-ETX (MIL-W-16878/6) C = Crosslinked modified ETFE insulation, silver coated high strength copper, SAE AS22759/33 E = Crosslinked modified ETFE insulation, low fluoride, lightweight, silver-coated high strength copper alloy, SAE AS22759/51 F = Crosslinked modified ETFE insulation, low fluoride, lightweight, silver-coated copper, SAE AS22759/52
Wire Color	1 = White 2 = Yellow 7 = 10 Color Repeating (Wire Type A is striped, Types B, C, E, and F are solid colors)
Wire Length (Inches)	12 = 12.00 + 1.00 Inches; as required in one inch increments.

RECEPTACLE MATING FACE VIEW AND CONTACT LAYOUT (POSITION IDENTIFICATIONS NOT MARKED ON PART)					
Size 1-4 4 Contacts	Size 1-7 7 Contacts	Size 2-19 19 Contacts	Size 3-37 37 Contacts	Size 4-44 44 Contacts	Size 4-55 55 Contacts

PERFORMANCE SPECIFICATIONS	
Contact Spacing: .025" (0.64) contact centers	Vibration: 20 g's, IAW EIA-364-28, Condition IV
Wire Accommodation: #30-#32 AWG	Shock: 100 g's, IAW EIA-364-27, Condition G
Current Rating: 1 AMP maximum tested per EIA-364-70	Durability: 200 mating cycles per test procedure EIA-364-09
DWV: 250 VAC RMS sea level, 100 VAC RMS 70,000 feet per EIA-364 Procedure 20	Corrosion Resistance: 48 hours salt spray IAW EIA-364-26, Condition B
Insulation Resistance: 5000 Megohms minimum test voltage 100 VDC, per EIA-364 Procedure 21	Humidity: 240 hours, IAW EIA-364-31, Test Condition B
Operating Temperature: -55° C. to +125° C.	Contact Engaging/Separation Force: 5 ounce maximum, 0.4 ounce minimum
Contact Resistance: 71 millivolt drop maximum, 1 AMP current, any catalog supported wire type	Thermal Vacuum Outgassing: Total mass loss (TML) 1.0% max., volatile condensable material (VCM) 0.1% max. IAW ASTM E595

SERIES 89 NANOMINIATURE Threaded and Breakaway Nano Circulars



892-004 Inline, Breakaway Receptacle with Insulated Wire

DIMENSIONS	
892-004-01 Without Termination Platform	892-004-02 With Termination Platform
Size	Ø A ±.005 (±0.13)
1-4	.310 (7.87)
1-7	.310 (7.87)
2-19	.360 (9.14)
3-37	.411 (10.44)
4-44	.443 (11.25)
4-55	.443 (11.25)

KEYWAY POSITIONS			
Size	Polarization	A°	B°
1-4	N	150	210
	A	75	210
1-7	N	95	230
	A	140	275
2-19	N	150	210
	A	75	210
3-37	N	150	210
	A	75	210
4-44	N	150	210
	A	75	210
4-55	N	95	230
	A	140	275

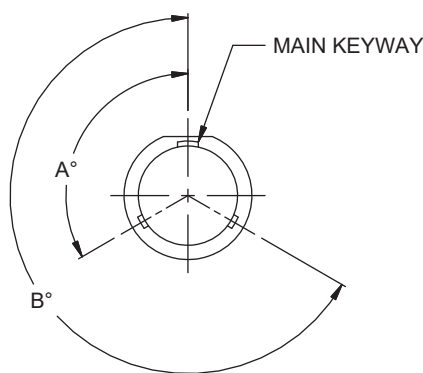

NOTES

- Material and finish shell, backshell and spanner nut:
 - A2: aluminum alloy, electroless nickel plated per SAE-AMS-2404, Class 3 or 4, Grade B
 - A5: aluminum alloy, gold plate per ASTM B488, Type I, Code C, over electroless nickel per ASTM B733 SC 2, Type IV, Class 4
 - S1: 300 Series stainless steel per ASTM A276, zinc cobalt (black) plating per ASTM B840 Gr 6, Type D, over nickel strike (not recommended for bonding resistance requirements)
 - S2: 300 Series stainless steel per ASTM A276, passivated IAW SAE AMS 2700
 - Insulator: liquid crystal polymer (LCP), per MIL-M-24519 GLCP-30F, 30% glass-filled
 - Contacts: gold alloy/unplated
 - Wire: see part number development
 - EMI Spring: stainless steel/gold plate
- Inspect and test per MIL-DTL-32139
- Replacement parts:
 - Internal O-ring: 899-021
 - EMI spring: 899-022