



0500-3034

DATASHEET

D-SUB ELECTRO-OPTICAL CONNECTOR
2 x GLENAIR SIZE #8 ELECTRO-OPTICAL CONTACTS
MULTI-MODE, 1.25MM FERRULE ARINC 801
FRONT INSERT – FRONT RELEASE

REV	DESCRIPTION	DATE	APPROVED
1	Preliminary	08/05/2019	RAS/CAA/YA

BF19U2-7560

THIS COPYRIGHTED DOCUMENT IS THE PROPERTY OF GLENAIR, INC. AND IS FURNISHED ON THE CONDITION THAT IT IS NOT TO BE DISCLOSED, REPRODUCED IN WHOLE OR IN PART, OR USED TO SOLICIT QUOTATIONS FROM COMPETITIVE SOURCES, OR USED FOR MANUFACTURE BY ANYONE OTHER THAN GLENAIR, INC. WITHOUT WRITTEN PERMISSION FROM GLENAIR, INC. THE INFORMATION HEREIN HAS BEEN DEVELOPED AT GLENAIR'S EXPENSE AND MAY BE USED FOR ENGINEERING EVALUATION AND INCORPORATION INTO TECHNICAL SPECIFICATIONS AND OTHER DOCUMENTS WHICH SPECIFY PROCUREMENT OF PRODUCTS FROM GLENAIR, INC.

0500-3034 DATASHEET
D-Sub Electro-Optical Receptacle Connector
With 2x Glenair Size #8 Opto-Electronic Contacts



D-Sub Receptacle Connector with 2 x Size 8 Opto-Electronic Contacts

Glenair 0500-3034 series of Active Opto-electronic connector offers customers the power to convert from electrical to fiber optic signals within a D-Sub receptacle connector to support high speed fiber optic transmissions in harsh environments. The 0500-3034 incorporate Size 8 active contacts in multiple configurations to enable optical Transmitters, optical Receivers, or Optical Transceivers. The opto-electronic performance parameters of the 0500-3034 are defined by the performance of the Size 8 contacts that are incorporated**. For example, if one incorporates a 4.25Gbps contact into the connector then each of the contacts will be 4.25Gbps capable.

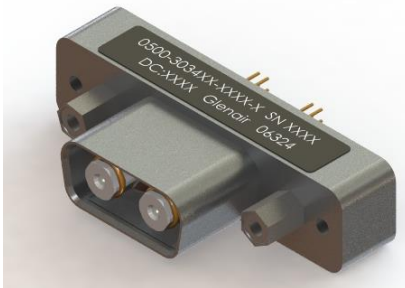

The fiber optic signal that is generated within the 0500-3034 active connector is transmitted through an ARINC 801 fiber optic connector interface to a fiber optic cable system using a D-Sub plug connector that has been fitted with adapters to incorporate ARINC 801 fiber optic contacts. This allows for proper housing and retaining of contacts at the required optical interface to achieve very repeatable low loss optical transmission characteristics.

The 059-0001 adapter converts D-Sub Size 8 cavities (twinax, coax, or quadax) into ARINC 801 LuxCis fiber optic connectors. For more information, please refer to 059-0001 sales drawing.

KEY FEATURES/BENEFITS

- 050-301 contacts to support ARINC 801 1.25mm fiber optic interconnect, 100Mbps to 5Gbps per contact
- 050-367 contacts to support ARINC 801 1.25mm fiber optic interconnect, 3G-SDI and HD-SDI
- 050-399 contacts to support DC to 10 Mbps and 0500-3015 contacts to support DC to 50 Mbps signals
- 059-0001 Adapters available to support converting PLUG D-Sub Size 8 cavities into ARINC 801 fiber optic compatible connectors

- PC tail electrical interfaces or custom micro-coax or flex to PCB interfaces available

APPLICATIONS

- Harsh Environment Airborne, Tactical and Shipboard applications
- Ethernet, Fast Ethernet, Gigabit Ethernet, AFDX, 1x/2x/4x Fiber Channel, DVI, HDMI, SFDP, Serial Rapid I/O (sRIO) and other high speed communication all over Multimode Fiber
- SMPTE HD & 3G-SDI Video Applications

How To Order

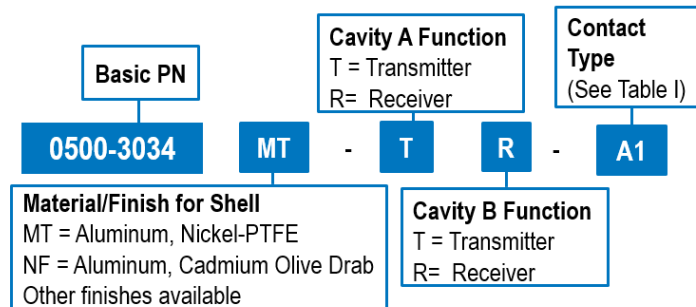

0500-3034 DATASHEET
D-Sub Electro-Optical Receptacle Connector
With 2x Glenair Size #8 Opto-Electronic Contacts



Table I: Contact Type				
Contact Type	Contact Option	Contact P/N	Description	Contact Type Description
A (Multimode 50/125 & 62.5/125)	1	050-301-01-T	1.25 Gbps Transmitter	050-301 series opto-electronic size #8 contact, 100Mbps – 5.00Gbps, 850nm VCSEL Transmitter or PIN/TIA Receiver, 1.25mm LuxCis optical interface that mates with ARINC 801 terminus**
		050-301-01-R	1.25 Gbps Receiver	
	2	050-301-02-T	2.50 Gbps Transmitter	
		050-301-02-R	2.50 Gbps Receiver	
	3	050-301-03-T	3.20 Gbps Transmitter	
		050-301-03-R	3.20 Gbps Receiver	
	4	050-301-04-T	4.25 Gbps Transmitter	
		050-301-04-R	4.25 Gbps Receiver	
	5	050-301-05-T	5.00 Gbps Transmitter	
		050-301-05-R	5.00 Gbps Receiver	
C (Multimode 50/125 & 62.5/125)	1	050-367-1-T	HD-SDI Transmitter	050-367 series opto-electronic size 8 contact, HD-SDI and 3G-SDI, 1.25mm LuxCis optical interface that mates with ARINC 801 terminus
		050-367-1-R	HD-SDI Receiver	
	2	050-367-T	3G-SDI Transmitter	
		050-367-R	3G-SDI Receiver	
D (Multimode 50/125 & 62.5/125)	1	050-399-01-TX	DC to 1 Mbps TX	050-399 series opto-electronic size 8 contact, DC to 10 Mbps, 1.25mm LuxCis optical interface that mates with ARINC 801 terminus
		050-399-01-RX	DC to 1 Mbps RX	
	2	050-399-02-TX	DC to 10 Mbps TX	
		050-399-02-RX	DC to 10 Mbps RX	
E (Multimode 50/125 & 62.5/125)	1	0500-3015-01-TX	DC to 50 Mbps TX	050-399 series opto-electronic size 8 contact, DC to 50 Mbps, 1.25mm LuxCis optical interface that mates with ARINC 801 terminus
		0500-3015-01-RX	DC to 50 Mbps RX	
X	X	N/A	No Contact, Empty	

* Note: For electrical ratings and specifications, please refer to 050-301, 050-367, 050-399, or 0500-3015 datasheets

0500-3034 DATASHEET
D-Sub Electro-Optical Receptacle Connector
With 2x Glenair Size #8 Opto-Electronic Contacts



Functional Block Diagram

Transmitter Functional Block Diagram per cavity

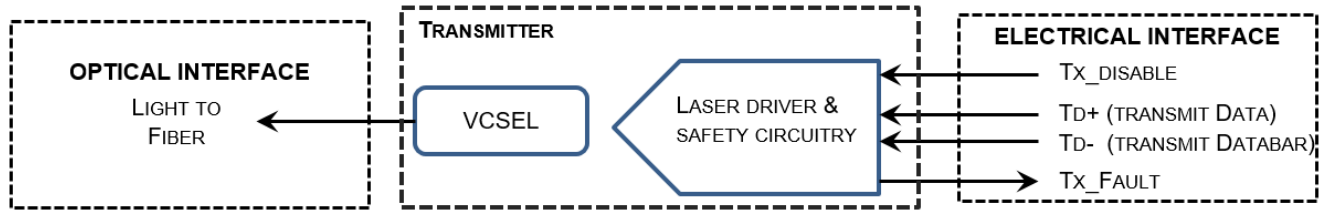

Receiver Functional Block Diagram per cavity

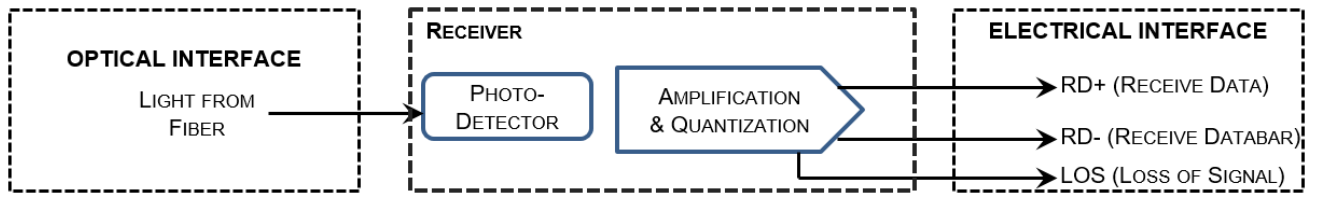

0500-3034 DATASHEET

D-Sub Electro-Optical Receptacle Connector With 2x Glenair Size #8 Opto-Electronic Contacts



Recommended Interface Circuit

Type "A" Size #8 Contact

Transmitter (050-301)

RECOMMENDED INTERFACE CIRCUIT

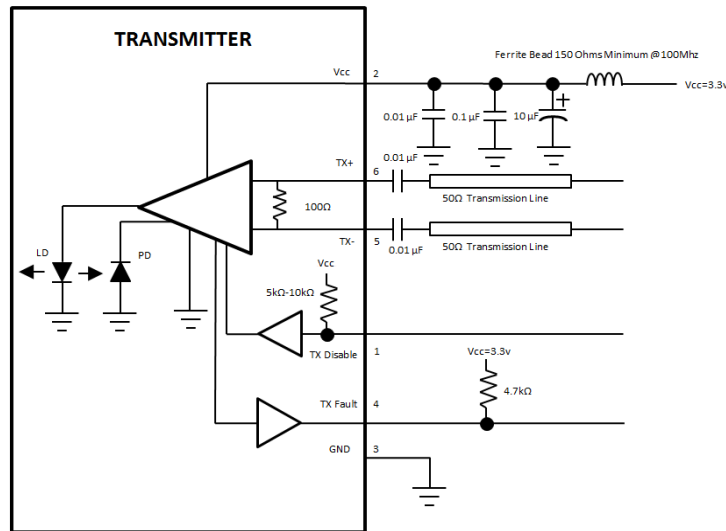

Receiver (050-301)

RECOMMENDED INTERFACE CIRCUIT

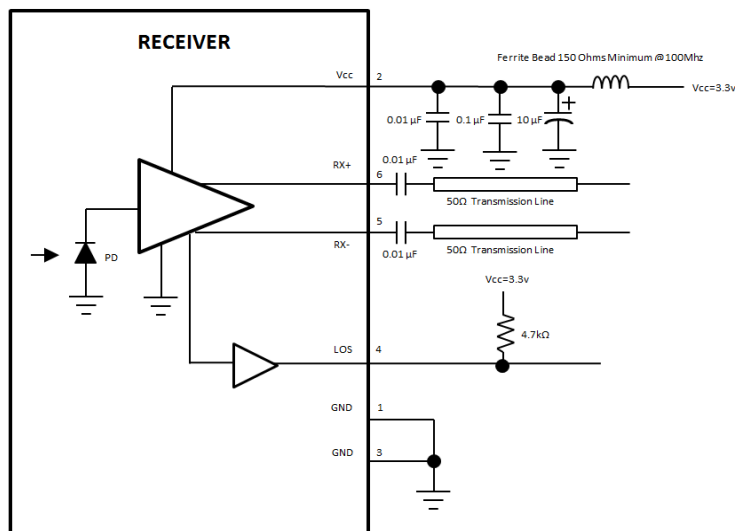

0500-3034 DATASHEET

D-Sub Electro-Optical Receptacle Connector With 2x Glenair Size #8 Opto-Electronic Contacts



Recommended Interface Circuit (continued)

Type "C" Size #8 Contact

Transmitter (050-367)

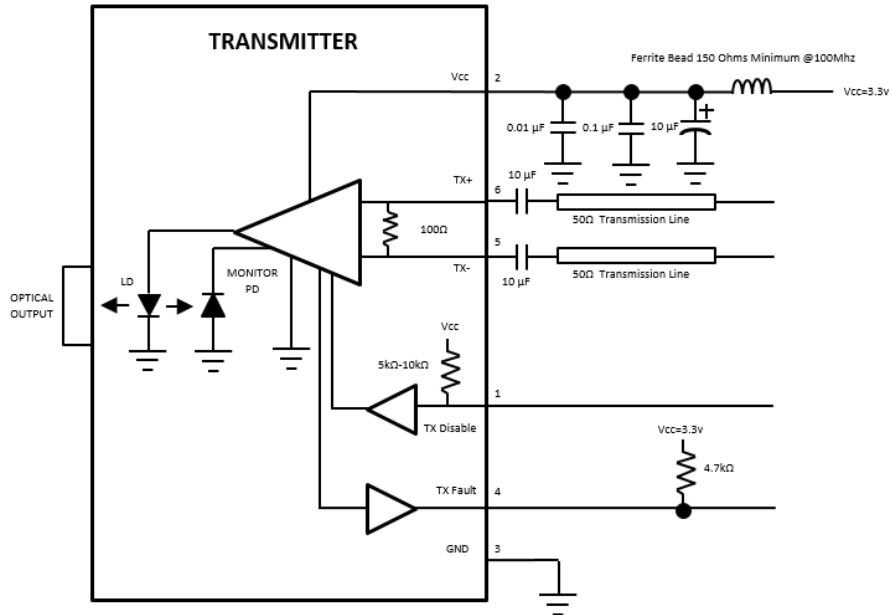

Receiver (050-367)

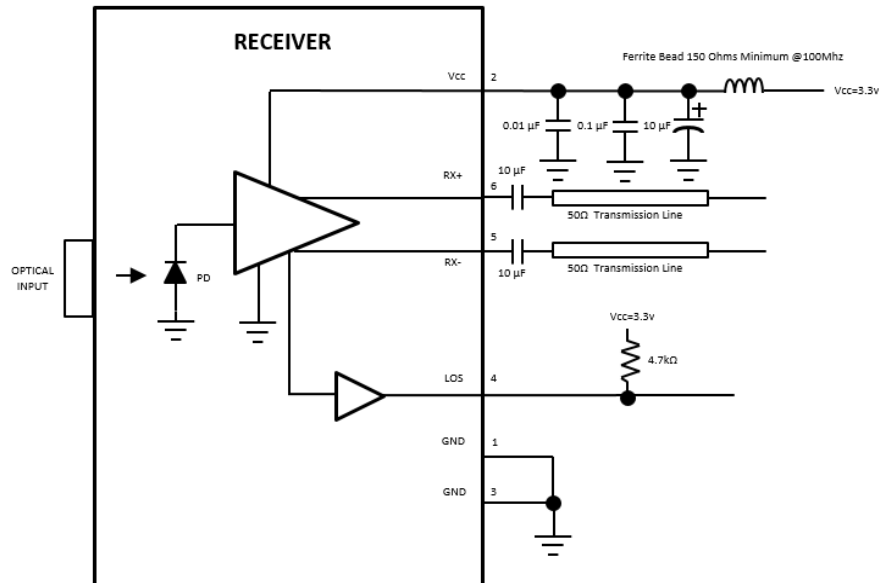

0500-3034 DATASHEET
D-Sub Electro-Optical Receptacle Connector
With 2x Glenair Size #8 Opto-Electronic Contacts



Recommended Interface Circuit -- (Continued)

Type "D" Size #8 Contact

Transmitter (050-399)

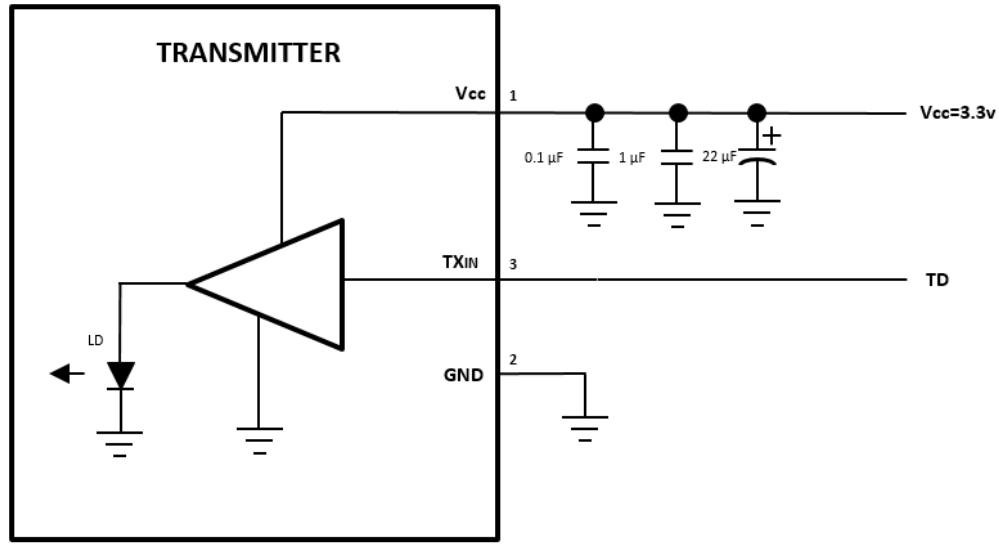

Receiver (050-399)

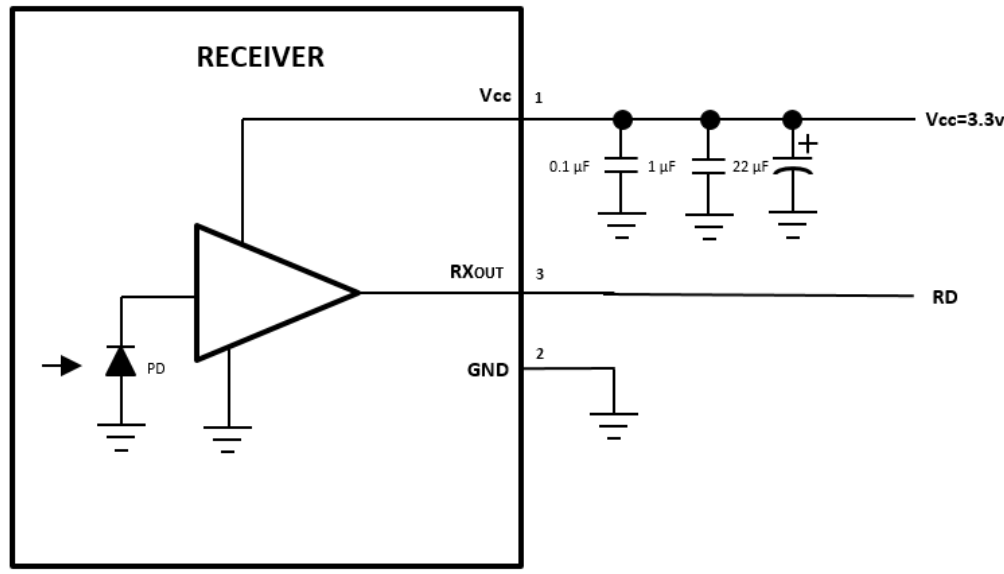

0500-3034 DATASHEET
D-Sub Electro-Optical Receptacle Connector
With 2x Glenair Size #8 Opto-Electronic Contacts



Recommended Interface Circuit -- (Continued)

Type "E" Size #8 Contact

Transmitter (0500-3015)

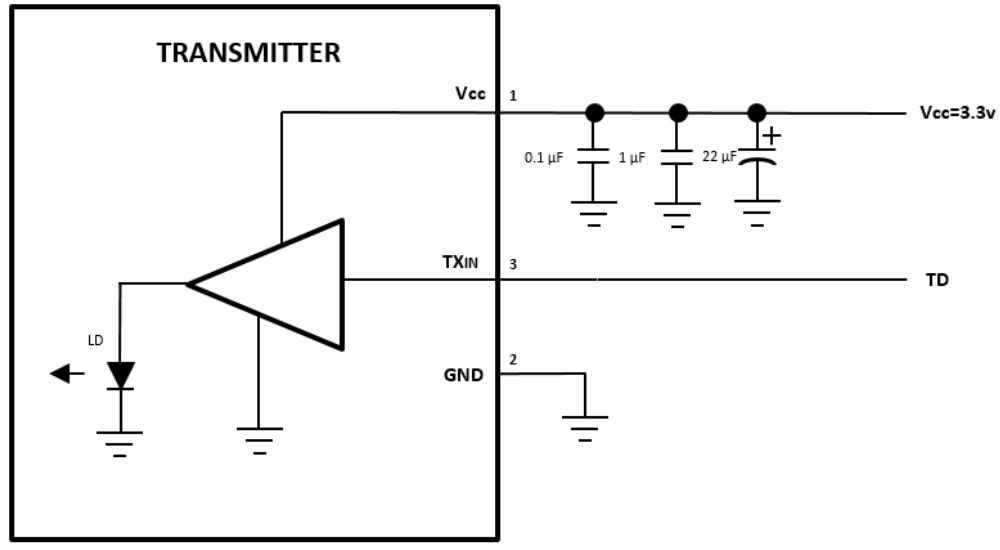

Receiver (0500-3015)

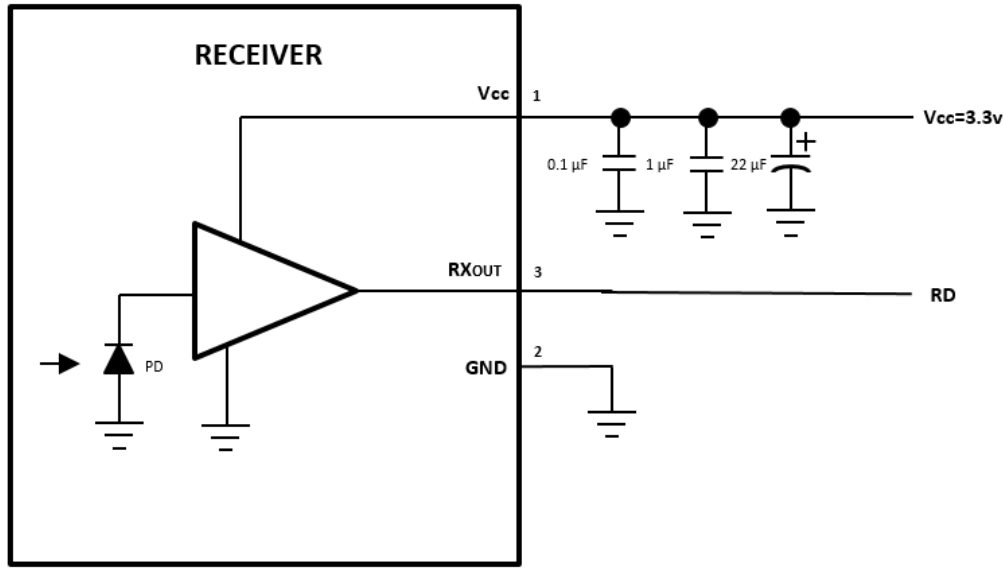

0500-3034 DATASHEET
D-Sub Electro-Optical Receptacle Connector
With 2x Glenair Size #8 Opto-Electronic Contacts

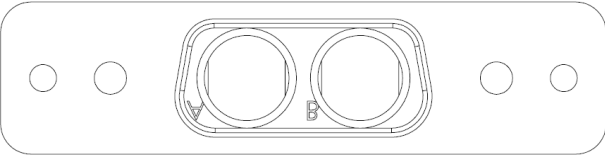

Connectors

NAME	Insert Arrangement	Function	Receptacle OE Converter	Mating PLUG Connector
J1		Electro-Optical Conversion	Contacts are contained within the connector	Glenair PN 059-0063 181-076-P-126 126.0 micron, pull proof design, MMF

Note: # = Environmental Class (Material/Finish)

Note: For electrical ratings and specifications, please refer to 050-301, 050-367, 050-399, or 0500-3015 datasheets.

0500-3034 DATASHEET
D-Sub Electro-Optical Receptacle Connector
With 2× Glenair Size #8 Opto-Electronic Contacts



Ratings and Specifications

Compliance Specifications

CHARACTERISTIC	Standard	Condition	Notes
Mechanical Shock	MIL-STD-810	40g	6 ms
Mechanical Vibration	MIL-STD-810	30g rms	
ESD	MIL-STD-883	Class 1C	1000V HBM
Eye Safety	CDRH and IEC-825	Class 1 Laser Product	No safety interlocks required

Material/Finish

Item	Material/Finish
050-3001 Shell	Aluminum, 300 Series CRES
Contact Shell	Shell 300 Series CRES/Passivate or NM6
Seal	Silicone elastomer
Fiber Ferrule & sleeve	Zirconia ceramic
PC tail contacts	Copper alloy/gold plated
PCB flex	FR4 & Polyimide
Encapsulant	HYSOL EE4215
Solder type	RoHS compliant Sn95/Sb5 (232°C melting temp) & RoHS compliant Sn96.5/Ag3.0/Cu0.5 (217° melting)

0500-3034 DATASHEET
D-Sub Electro-Optical Receptacle Connector
With 2x Glenair Size #8 Opto-Electronic Contacts



Figure 1 - OUTLINE DRAWING

Recommended Panel Cut Out

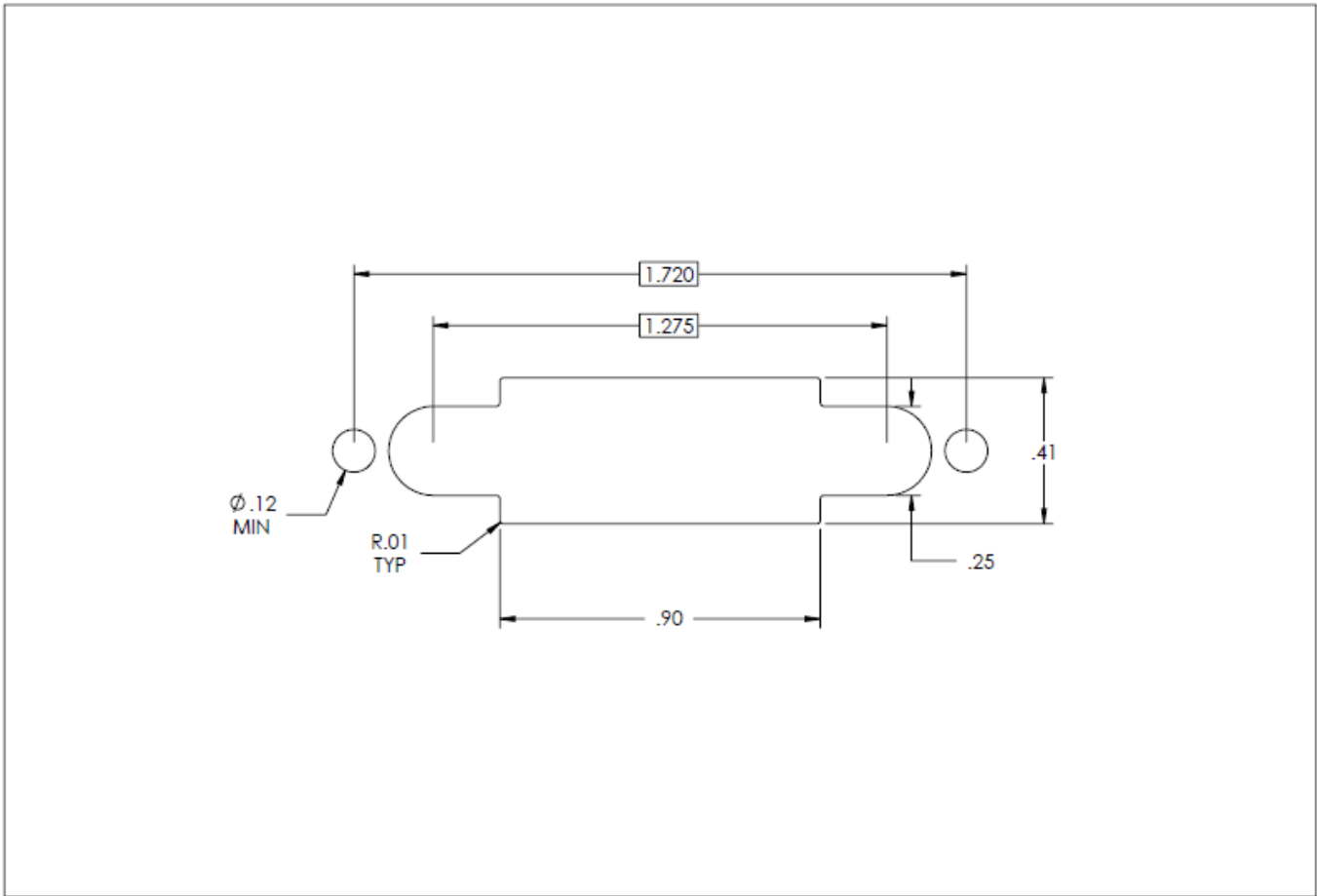

0500-3034 DATASHEET
D-Sub Electro-Optical Receptacle Connector
With 2x Glenair Size #8 Opto-Electronic Contacts



Figure 1 - OUTLINE DRAWING – (Continued)

With Contacts Type A (050-301) & Type C (050-367)

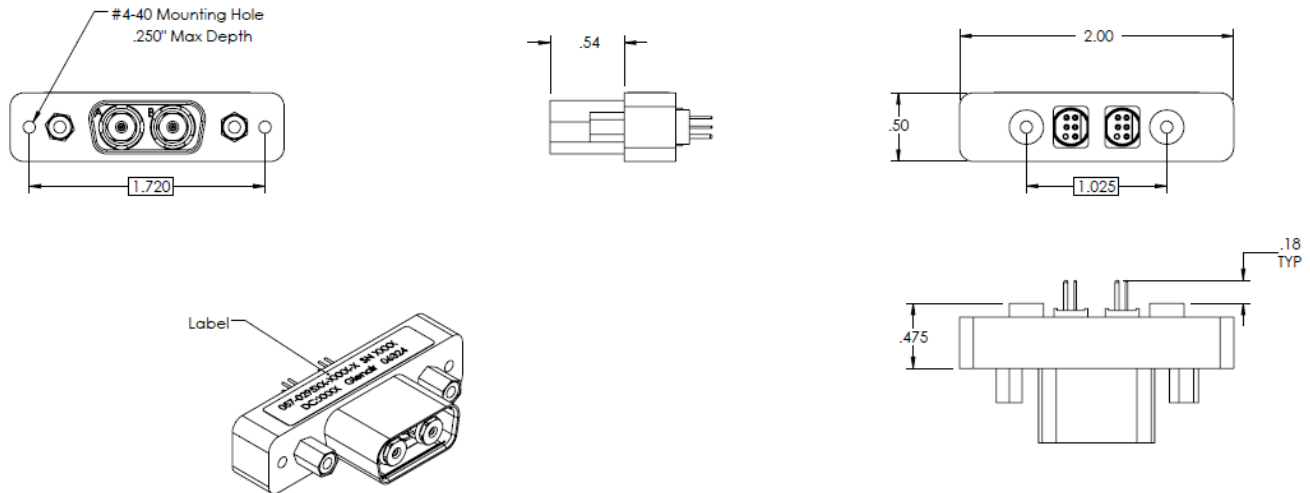

Label includes part number, serial number, date code, manufacturer and cage code.

Dimensions inches

x.x ± 0.1"

x.xx ± 0.03"

x.xxx ± 0.005"

Recommended PCB Layout
With Contacts Type A (050-301) & Type C (050-367)

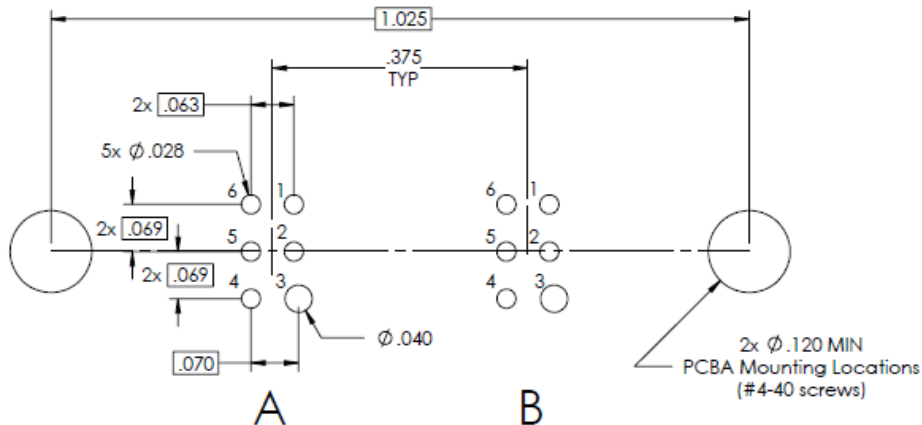

Note: For pinout definition, please refer to 050-301, 050-367 datasheets.

0500-3034 DATASHEET
D-Sub Electro-Optical Receptacle Connector
With 2x Glenair Size #8 Opto-Electronic Contacts



Figure 1 - OUTLINE DRAWING – (Continued)

With Transmitter Contacts Type D (050-399-0x-TX) & Type E (0500-3015-0x-TX)

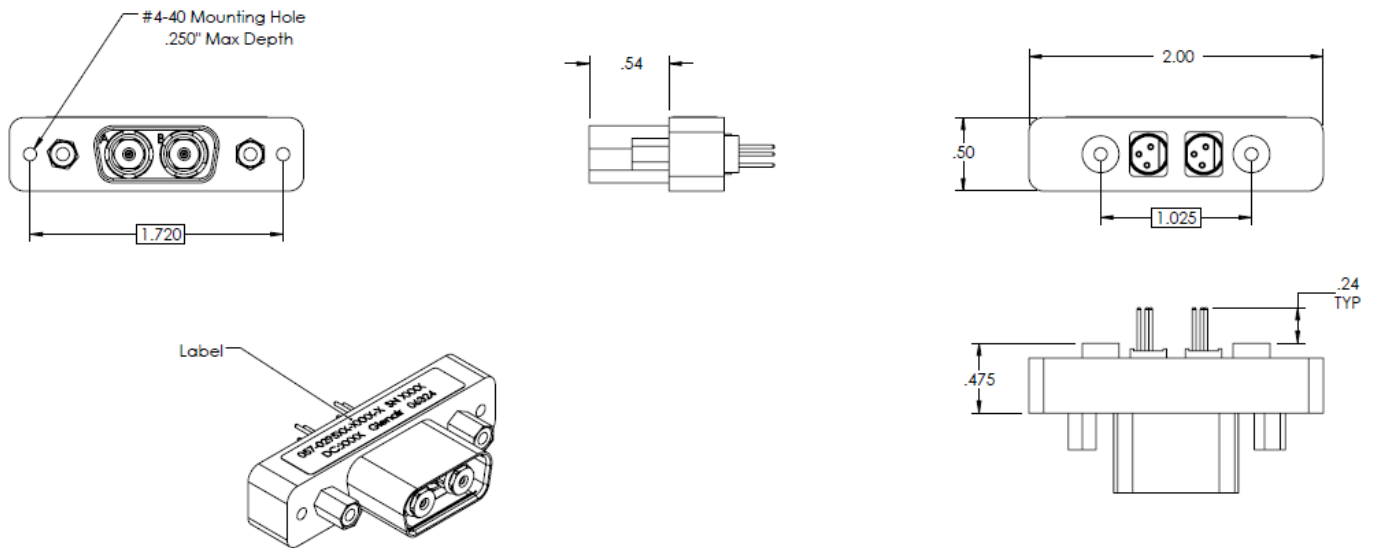

Label includes part number, serial number, date code, manufacturer and cage code.

Dimensions inches
 x.x ± 0.1"
 x.xx ± 0.03"
 x.xxx ± 0.005"

Recommended PCB Layout

With Transmitter Contacts Type D (050-399-0x-TX) & Type E (0500-3015-0x-TX)

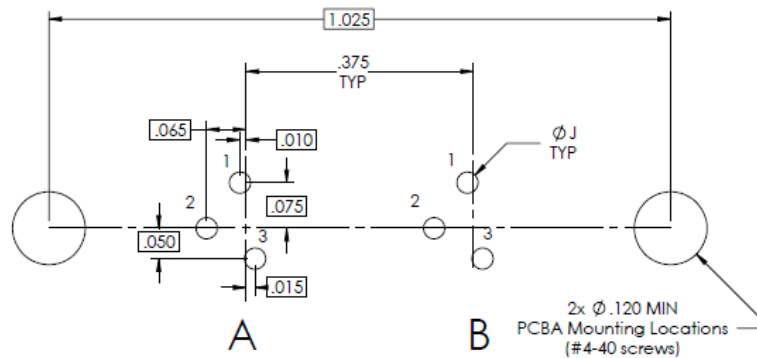

Note: For pinout definition, please refer to 050-399, 0500-3015 datasheets.

0500-3034 DATASHEET
D-Sub Electro-Optical Receptacle Connector
With 2x Glenair Size #8 Opto-Electronic Contacts



Figure 1 - OUTLINE DRAWING – (Continued)

With Receiver Contacts Type D (050-399-0x-RX) & Type E (0500-3015-0x-RX)

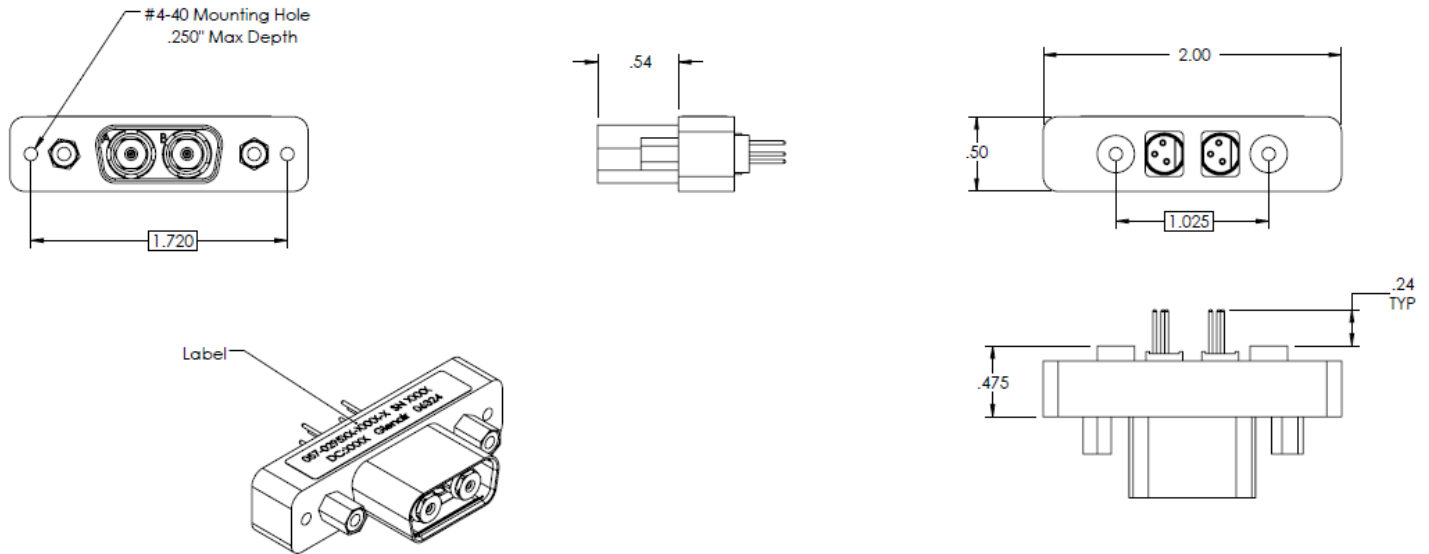

Label includes part number, serial number, date code, manufacturer and cage code.

Dimensions inches
 x.x ± 0.1"
 x.xx ± 0.03"
 x.xxx ± 0.005"

Recommended PCB Layout
With Receiver Contacts Type D (050-399-0x-RX) & Type E (0500-3015-0x-RX)

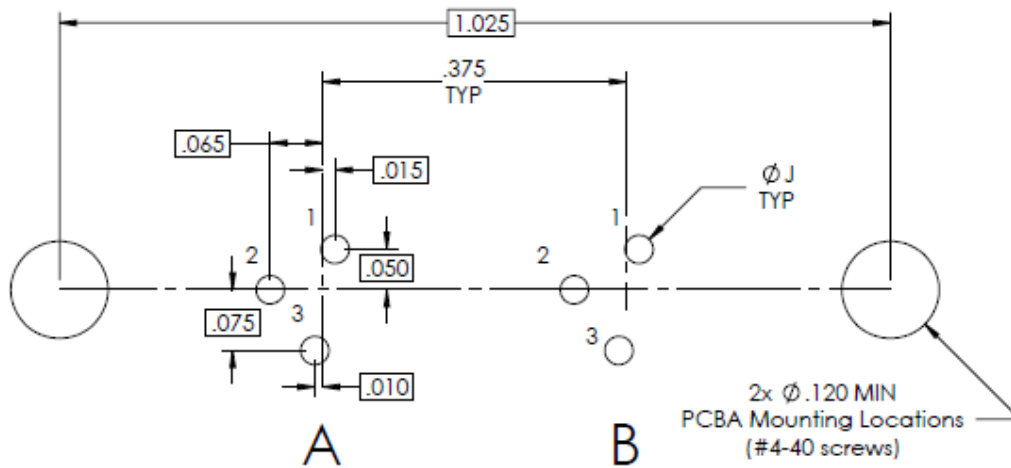

Note: For pinout definition, please refer to 050-399, 0500-3015 datasheets.

0500-3034 DATASHEET
D-Sub Electro-Optical Receptacle Connector
With 2x Glenair Size #8 Opto-Electronic Contacts



Recommended Inspection & Cleaning Tools/Kits

The following recommendations are suggested for this product:

- **GBS-1001 Inspection Kit** which includes **GIT-003** tip for **ARINC 801** fiber contacts.
- **GCLT-H200** or **GCLT-HA125** cleaning tool for **ARINC 801** system.

GBS1001 Inspection Probe with USB Adapter and Fiber Chek 2 Software



How To Order

GBS1001

Basic Part Number Includes:

- *Inspection probe with USB adapter*
- *Fiber Chek 2 Software*

Comes with

(installed on the probe):

GIT-003 Universal 1.25mm patch cord

The GBS1001 is the only inspection probe today with a high resolution, all digital sensor and USB2 video stream which delivers high-resolution uncompressed images directly to your personal computer.

GBS1001 Specifications

Weight	.11 Kg / .25 lb
Resolution	Better than 1.5 Microns
Cable	Integrated USB 2.0 coil cable 2.5' relaxed, 10.5' fully extended
Certification	CE
Warranty	1 year

Fiber Chek Software

Fiber Optic Analysis Program

Fiber Chek is an integrated hardware/software package engineered with the single purpose of critically and consistently grading fiber end-faces. Works hand in hand with the Quick Capture Analog Probe for visual inspection, taking pictures and testing fibers.

- Automatic debris and defect detection, including fine scratches
- Measures epoxy ring for out-of-tolerance conditions
- Inspection results, including image data, can be printed or archived
- Utilizes industry standards or user defined threshold settings

Recommended Inspection & Cleaning Tools/Kits – (Continued)

Dry action cleaning tool for ARINC 801 systems



Dry action cleaning tool for ARINC 801 test adapters



- A simple push motion engages tool
- Audible click when tool is fully engaged
- Durable — over 525 engagements per tool
- Crush resistant to over 250N
- Impact resistant to survive drops over 1.5M