



050-304

DATASHEET

SIZE 8 ELECTRO-OPTICAL CONTACT TRANSMITTER OR RECEIVER MULTI-MODE, 1.25MM FERRULE ARINC 801 FRONT INSERT – FRONT RELEASE

REV	DESCRIPTION	DATE	APPROVED
A	Released	08/09/2016	GC/SZ/NH
B	Per DCN62573; Edit Arrangement G4 to refer to MIL-STD-1560C, Add Arrangement H5 and J8	11/03/2016	SZ/NH/GC
C	Per DCN64829; Changed mating connectors from 257-606 series to 233-217 series	04/21/2017	SZ/NH/GC
D	Fixed language in description	01/29/2018	JLL
E	Per DCN70264; General Update	04/26/2018	RAS/GC
F	Per DCN72776; Add 050-399 and 0500-3015 contact options	10/30/2018	RAS/GC
G	Per DCN74331; Add FO Inspection/ Cleaning Tools. Add the PCB Layouts for all possible arrangements	02/06/2019	YA
H	Per DCN74510; Update the Contact P/Ns in Table II, Update the BID number	02/18/2019	YA
J	Per DCN77147; Add the DC to 10 Mbps Contact Type in Table II, Add DC-Coupled contacts as an option in the Key Features, Add a Note to refer to contacts' datasheets for electrical ratings.	08/06/2019	YA

BF12U2-2542

THIS COPYRIGHTED DOCUMENT IS THE PROPERTY OF GLENAIR, INC. AND IS FURNISHED ON THE CONDITION THAT IT IS NOT TO BE DISCLOSED, REPRODUCED IN WHOLE OR IN PART, OR USED TO SOLICIT QUOTATIONS FROM COMPETITIVE SOURCES, OR USED FOR MANUFACTURE BY ANYONE OTHER THAN GLENAIR, INC. WITHOUT WRITTEN PERMISSION FROM GLENAIR, INC. THE INFORMATION HEREIN HAS BEEN DEVELOPED AT GLENAIR'S EXPENSE AND MAY BE USED FOR ENGINEERING EVALUATION AND INCORPORATION INTO TECHNICAL SPECIFICATIONS AND OTHER DOCUMENTS WHICH SPECIFY PROCUREMENT OF PRODUCTS FROM GLENAIR, INC.

050-304 DATASHEET

D38999 Series III Type Active Receptacle Connector With Glenair Size #8 Opto-Electronic Contacts



MIL-DTL-38999 type Receptacle Connector with Size 8 Opto-Electronic Contacts

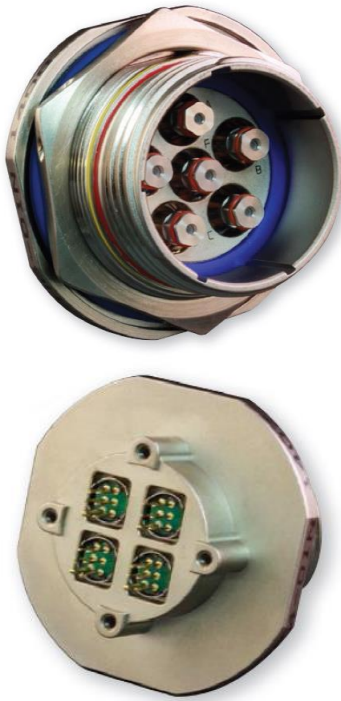

Glenair 050-304 series of Active Opto-electronic panel mount connectors offers customers the power to convert from electrical to fiber optic signals within a D38999 connector to support high speed fiber optic transmissions in harsh environments. The 050-304s incorporate size 8 active contacts in one of the three standard configurations to enable optical Transmitters, optical Receivers, or Optical Transceivers. The opto-electronic performance parameters of the 050-304 are defined by the performance of the size 8 contacts that are incorporated. For example, if one incorporates a 4.25Gbps contact into the connector then each of the contacts will be 4.25Gbps capable.

The fiber optic signal that is generated within the 050-304 active connector is transmitted via ARINC 801 fiber optic connector interface to fiber optic cable systems using a standard D38999 plug connector that has been fitted with adapters to incorporate ARINC 801 fiber optic contacts. For example a D38999 plug connector with size 8 contact cavities, such as a 25-08 insert arrangement (per MIL-DTL-1560) can be fitted with Glenair ARINC 801 contact adapters that convert this electrical connector into a fiber optic connector that enables it to properly house and retain contacts at the required optical interface to achieve very repeatable low loss optical transmission characteristics.

The 059-0001 adapter converts D38999 size 8 cavities (twinax, coax, or quadrax) into ARINC 801 LuxCis fiber optic connectors. For more information, please refer to 059-0001 sales drawing.

KEY FEATURES/BENEFITS

- MIL-STD-1560 arrangements & Glenair arrangements
- Arrangements from 1 - 8 Size 8 cavities available, contact factor for custom arrangements
- May be configured in 1 of 3 standard configurations: Transmitter, Receiver or Transceiver
- 050-301 contacts to support ARINC 801 1.25mm fiber optic interconnect, 100Mbps to 4.25Gbps per contact
- 050-367 contacts to support ARINC 801 1.25mm fiber optic interconnect, 3G-SDI and HD-SDI
- DC-Coupled contacts, 050-399 and 0500-3015, to support DC to 50 Mbps signals.
- 059-0001 Adapters available to support converting PLUG D38999 Size 8 cavities into ARINC 801 fiber optic compatible connectors
- PC tail electrical interfaces or custom micro-coax or flex to PCB interfaces available
- Connector rear face contains standoffs to allow direct mechanical attachment to PCB

APPLICATIONS

- Harsh Environment such as: Airborne, Tactical, Railway, Industrial, Oil and Gas and Shipboard applications
- Ethernet, Fast Ethernet, Gigabit Ethernet, AFDX, 1x/2x/4x Fiber Channel, DVI, HDMI, SFDP, Serial Rapid I/O (sRIO) and other high speed communication all over Multimode Fiber

050-304 DATASHEET

D38999 Series III Type Active Receptacle Connector
With Glenair Size #8 Opto-Electronic Contacts



How To Order

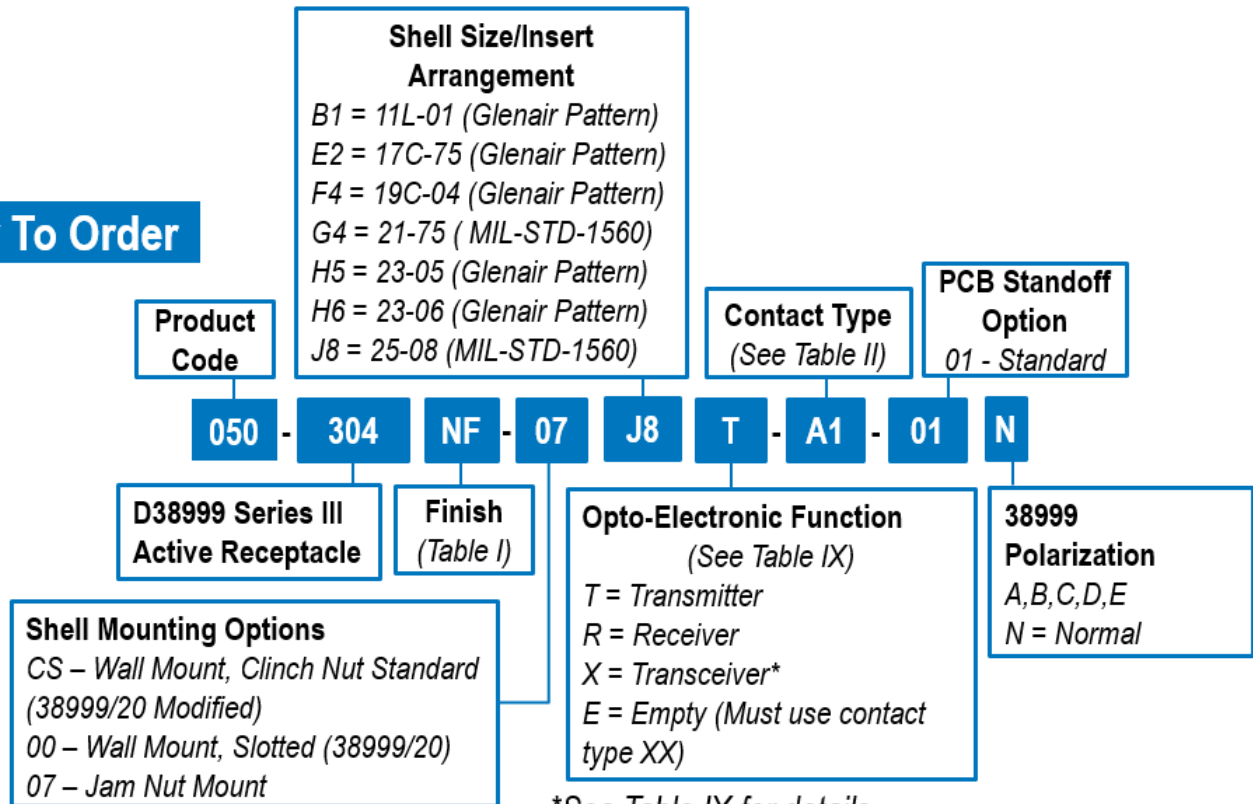

*See Table IX for details

Notes:

- This connector is designed to meet applicable dimensional, environmental, and performance characteristics of D38999 Series III per appropriate material class
- For opto-electric performance specifications, see Table II
- This connector mates with standard MIL-DTL-38999/26 plug connector. See Table X for applicable part numbers
- For cleaning tools and instructions, see GCLT-H125 in Glenair Fiber Optic Catalog
- Receptacle and plug cavity adapter contact removal tool: M81969/14-12
Plug optical contact insertion/removal tool: M81969/14-03
- For electrical ratings and specifications, please refer to 050-301, 050-367, 050-399, and 050-3015 datasheets.

050-304 DATASHEET

D38999 Series III Type Active Receptacle Connector
With Glenair Size #8 Opto-Electronic Contacts



Table I: Material And Finish		
SYM	Material	Finish Description
M	Aluminum	Electroless Nickel
MT		Nickel – PTFE
NF		Cadmium, Olive Drab
ZR		Zinc Ni, Black (Tri-Valent CR)
MA		Electroless Nickel Plate, Matte
Z1	Stainless Steel	Passivate
ZL		Electro-Deposited Nickel

Table II: Contact Type				
Contact Type	Contact Option	Contact P/N	Description*	Contact Type Description*
A (Multimode 50/125 & 62.5/125)	1	050-301-01-T	1.25 Gbps Transmitter	050-301 series opto-electronic size #8 contact, 100Mbps – 5.00Gbps, 850nm VCSEL Transmitter or PIN/TIA Receiver, 1.25mm LuxCis optical interface that mates with ARINC 801 terminus**
		050-301-01-R	1.25 Gbps Receiver	
	2	050-301-02-T	2.50 Gbps Transmitter	
		050-301-02-R	2.50 Gbps Receiver	
	3	050-301-03-T	3.20 Gbps Transmitter	
		050-301-03-R	3.20 Gbps Receiver	
	4	050-301-04-T	4.25 Gbps Transmitter	
		050-301-04-R	4.25 Gbps Receiver	
	5	050-301-05-T	5.00 Gbps Transmitter	
		050-301-05-R	5.00 Gbps Receiver	
C (Multimode 50/125 & 62.5/125)	1	050-367-1-T	HD-SDI Transmitter	
		050-367-1-R	HD-SDI Receiver	
	2	050-367-T	3G-SDI Transmitter	
		050-367-R	3G-SDI Receiver	
D (Multimode 50/125 & 62.5/125)	1	050-399-01-TX	DC to 1 Mbps TX	
		050-399-01-RX	DC to 1 Mbps RX	
	2	050-399-02-TX	DC to 10 Mbps TX	
		050-399-02-RX	DC to 10 Mbps RX	
E (Multimode 50/125 & 62.5/125)	1	0500-3015-01-TX	DC to 50 Mbps TX	
		0500-3015-01-RX	DC to 50 Mbps RX	
X	X	N/A	No Contact, Empty	

*Note: For electrical ratings and specifications, please refer to 050-301, 050-367, 050-399, and 050-3015 datasheets.

050-304 DATASHEET

D38999 Series III Type Active Receptacle Connector
With Glenair Size #8 Opto-Electronic Contacts



Active MIL-DTL-38999 type Wall-Mount Clinch Nut Receptacle

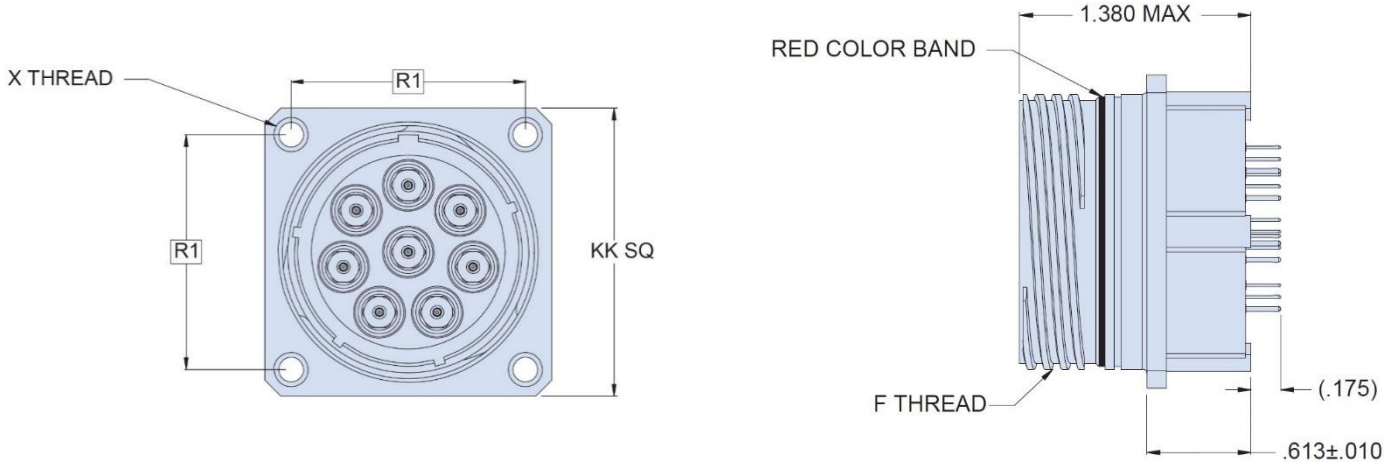

CS – Wall Mount, Clinch Nut (38999/20 Modified)

Table V: Dimensions for Clinch Nut Receptacles

Shell Size Code	Shell Size	F Thread Per M38999/20	X Thread	R1 Per D38999	KK SQ ± .010
B	11	.7500-.1P-.3L-TS-2A	#4-40	0.812 (20.6)	1.200 (30.5)
E	17	1.875-.1P-.3L-TS-2A	#4-40	1.062 (27.0)	1.450 (36.8)
F	19	1.2500-.1P-.3L-TS-2A	#4-40	1.156 (29.4)	1.550 (39.4)
G	21	1.3750-.1P-.3L-TS-2A	#4-40	1.250 (31.8)	1.650 (41.9)
H	23	1.5000-.1P-.3L-TS-2A	#6-32	1.375 (34.9)	1.770 (45.0)
J	25	1.6250-.1P-.3L-TS-2A	#6-32	1.500 (38.1)	1.900 (48.3)

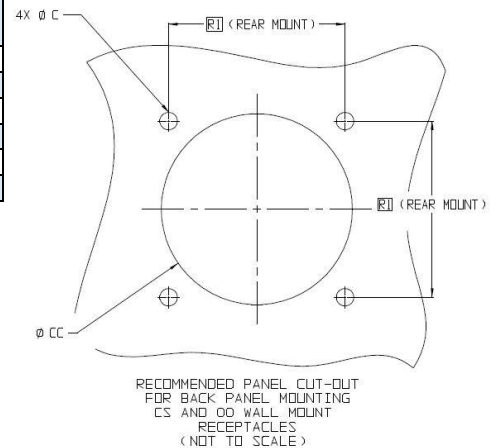

Table VI: Recommended Panel Cut-Out

Shell Size Code	Shell Size	ØC ±.005	ØCC min
A	11	0.128 (3.3)	0.796 (20.2)
E	17	0.128 (3.3)	1.219 (31.0)
F	19	0.128 (3.3)	1.297 (32.9)
G	21	0.128 (3.3)	1.422 (36.1)
H	23	0.154 (3.9)	1.547 (39.3)
J	25	0.154 (3.9)	1.672 (42.5)

050-304 DATASHEET

D38999 Series III Type Active Receptacle Connector
With Glenair Size #8 Opto-Electronic Contacts



Active MIL-DTL-38999 type Wall-Mount Slotted Receptacle

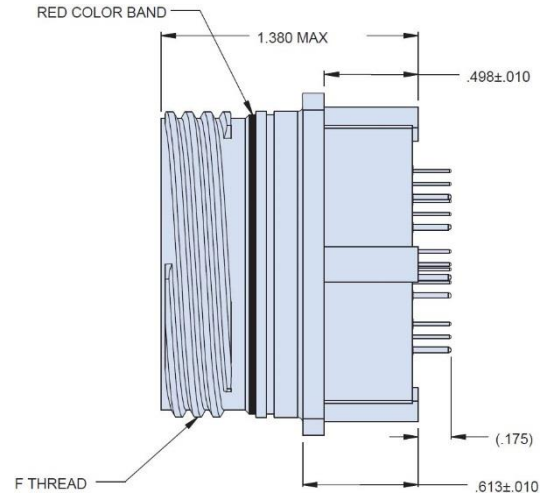
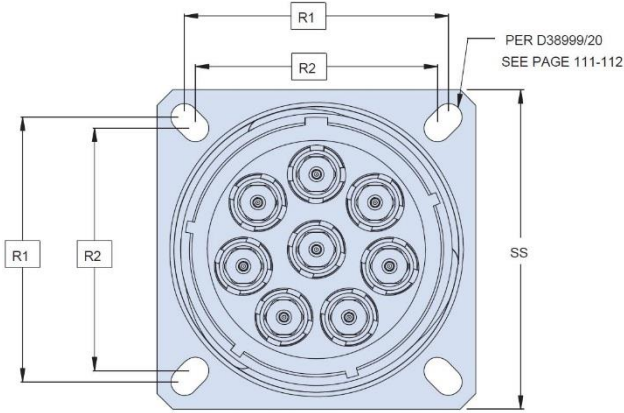

00 – Wall Mount, Slotted (38999/20)

Table VII: Dimensions for Slotted Receptacles

Shell Size Code	Shell Size	F Thread Per M38999/20	R1 Per D38999	R2 Per D38999	SS SQ ± .010
B	11	.7500-.1P-.3L-TS-2A	0.812 (20.6)	0.719 (18.3)	1.032 (26.2)
E	17	1.875-.1P-.3L-TS-2A	1.062 (27.0)	0.969 (24.6)	1.311 (33.3)
F	19	1.2500-.1P-.3L-TS-2A	1.156 (29.4)	1.062 (27.0)	1.437 (36.5)
G	21	1.3750-.1P-.3L-TS-2A	1.250 (31.8)	1.156 (29.4)	1.563 (39.7)
H	23	1.5000-.1P-.3L-TS-2A	1.375 (34.9)	1.250 (31.8)	1.689 (42.9)
J	25	1.6250-.1P-.3L-TS-2A	1.500 (38.1)	1.375 (34.9)	1.811 (46.0)

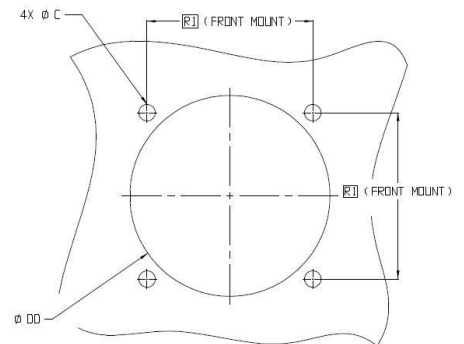

RECOMMENDED PANEL CUT-OUT FOR FRONT PANEL MOUNTING OF WALL MOUNT RECEPTACLES (NOT TO SCALE)

Table VIII: Recommended Panel Cut-Out

Shell Size Code	Shell Size	ØC ±.005	ØCC min	ØDD min
B	11	0.128 (3.3)	0.796 (20.2)	0.800 (20.3)
E	17	0.128 (3.3)	1.219 (31.0)	1.170 (29.7)
F	19	0.128 (3.3)	1.297 (32.9)	1.275 (32.4)
G	21	0.128 (3.3)	1.422 (36.1)	1.275 (32.4)
H	23	0.154 (3.9)	1.547 (39.3)	1.525 (38.7)
J	25	0.154 (3.9)	1.672 (42.5)	1.700 (43.2)

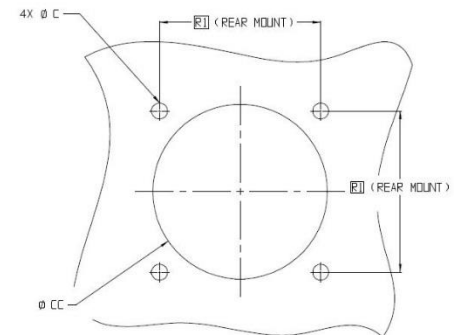

RECOMMENDED PANEL CUT-OUT FOR BACK PANEL MOUNTING OF WALL MOUNT RECEPTACLES (NOT TO SCALE)

050-304 DATASHEET

D38999 Series III Type Active Receptacle Connector
With Glenair Size #8 Opto-Electronic Contacts



Active MIL-DTL-38999 type Jam Nut Receptacle

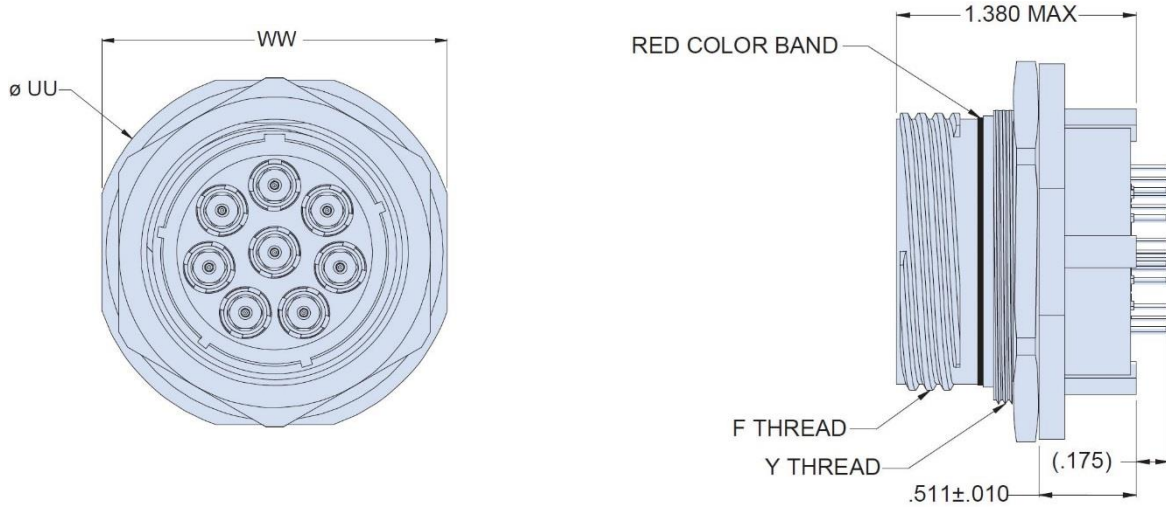

07 – Jam Nut Mount (38999/24)

Shell Size Code	Shell Size	F Thread Per M38999/20	Y Thread Per M38999/24	$\varnothing UU \pm 0.010$	WW sq ± 0.010
B	11	.7500-.1P-.3L-TS-2A	M20 X 1.0-6g 0.100R	1.377 (35.0)	1.259 (32.0)
E	17	1.875-.1P-.3L-TS-2A	M32 X 1.0-6G 0.100R	1.752 (44.5)	1.625 (41.3)
F	19	1.2500-.1P-.3L-TS-2A	M35 X 1.0-6G 0.100R	1.937 (49.2)	1.822 (46.3)
G	21	1.3750-.1P-.3L-TS-2A	M38 X 1.0-6G 0.100R	2.063 (52.4)	1.940 (49.3)
H	23	1.5000-.1P-.3L-TS-2A	M41 X 1.0-6G 0.100R	2.190 (55.6)	2.073 (52.7)
J	25	1.6250-.1P-.3L-TS-2A	M44 X 1.0-6G 0.100R	2.311 (58.7)	2.189 (55.6)

Shell Size Code	Shell Size	$\varnothing AA$ (min) Per M38999/24 $\pm .005$	$\varnothing BB$ (min) Per M38999/24 $\pm .005$
B	11	0.128 (3.3)	0.796 (20.2)
E	17	0.128 (3.3)	1.219 (31.0)
F	19	0.128 (3.3)	1.297 (32.9)
G	21	0.128 (3.3)	1.422 (36.1)
H	23	0.154 (3.9)	1.547 (39.3)
J	25	0.154 (3.9)	1.672 (42.5)

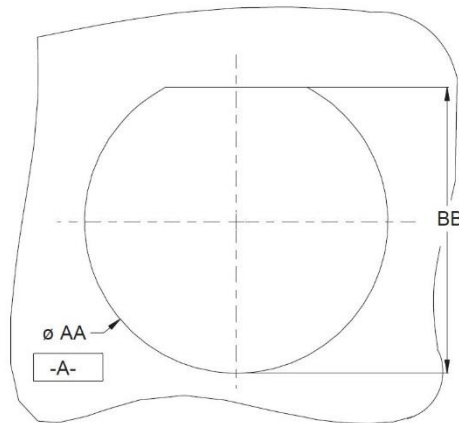

RECOMMENDED PANEL CUT-OUT FOR JAM NUT RECEPTACLE (NOT TO SCALE)

050-304 DATASHEET

D38999 Series III Type Active Receptacle Connector
With Glenair Size #8 Opto-Electronic Contacts



Insert Arrangements and PCB tails

Arrangement B1

Arr. 11L-01
1X #8
Glenair Special

Recommended PCB Layout		
Contact	Master Pin Position	
Position ID	X Position	Y Position
A	.000	.000

Arrangement E2

Arr. 17C-75
2X #8
Glenair Special

Recommended PCB Layout		
Contact	Master Pin Position	
Position ID	X Position	Y Position
A	.000	+.187
B	.000	-.187

Arrangement F4

Arr. 19C-04
4X #8
Glenair Special

Recommended PCB Layout		
Contact	Master Pin Position	
Position ID	X Position	Y Position
B	+.180	+.180
F	+.180	-.180
K	-.180	-.180
P	-.180	+.180

Arrangement G4

Arr. 21-75
4X #8
MIL-STD-1560C

Recommended PCB Layout		
Contact	Master Pin Position	
Position ID	X Position	Y Position
A	+.180	+.180
B	+.180	-.180
C	-.180	-.180
D	-.180	+.180

Arrangement H5

Arr. 23-05
5X #8
Glenair Special

Recommended PCB Layout		
Contact	Master Pin Position	
Position ID	X Position	Y Position
A	.000	+.364
B	+.347	+.113
C	+.214	-.295
D	-.214	-.295
E	-.347	+.113

Arrangement H6

Arr. 23-06
6X #8
Glenair Special

Recommended PCB Layout		
Contact	Master Pin Position	
Position ID	X Position	Y Position
A	.000	+.364
B	+.347	+.113
C	+.214	-.295
D	-.214	-.295
E	-.347	+.113
F	.000	.000

050-304 DATASHEET

D38999 Series III Type Active Receptacle Connector
With Glenair Size #8 Opto-Electronic Contacts

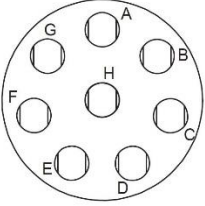

Insert Arrangements and PCB tails (continued)

Arrangement J8		
		
Arr. 25-08 8X #8 MIL-STD-1560C		
Recommended PCB Layout		
Contact Position ID	Master Pin Position	
	X Position	Y Position
A	.000	+.426
B	+.333	+.266
C	+.415	-.095
D	+.185	-.384
E	-.185	-.384
F	-.415	-.095
G	-.333	+.266
H	.000	.000

050-304 DATASHEET

D38999 Series III Type Active Receptacle Connector
With Glenair Size #8 Opto-Electronic Contacts



Function Assignments and Mating Connectors

Table IX: Function Assignments				
Insert Arrangement	Contact Position ID	T = Transmitter	R = Receiver	X* = Transceiver
B1	A	Transmitter	Receiver	N/A
	B			Transmitter
E2	A	Transmitter	Receiver	Transmitter
	B			Receiver
	B			Transmitter
	F			Receiver
F4	F	Transmitter	Receiver	Transmitter
	K			Receiver
	K			Transmitter
	P			Receiver
G4	A	Transmitter	Receiver	Transmitter
	B			Receiver
	C			Transmitter
	D			Receiver
H5	A	Transmitter	Receiver	Transmitter
	B			Receiver
	C			Transmitter
	D			Receiver
	E			Transmitter
H6	A	Transmitter	Receiver	Transmitter
	B			Receiver
	C			Transmitter
	D			Receiver
	E			Transmitter
	F			Receiver
J8	A	Transmitter	Receiver	Transmitter
	B			Receiver
	C			Transmitter
	D			Receiver
	E			Transmitter
	F			Receiver
	G			Transmitter
	H			Receiver

*Contact factory for other function assignments

For electrical ratings and specifications, please refer to 050-301, 050-367, 050-399, and 050-3015 datasheets.

Table XII: Mating Connector P/N				
Receptacle Connector Ins. Arr.	Mating Connector Description	Glenair P/N**	Contact Adapter Type A***	
			Qty	P/N
B1	Glenair Special	233-217-G6?11-1BN	1	059-0001
E2	Glenair Special	233-217-G6?17-75BN	2	059-0001
F4	Glenair Special	233-217-G6?19-4BN	4	059-0001
G4	D38999/26FG4SN	233-217-G6?21-75BN	4	059-0001
H5	Glenair Special	233-217-G6?23-5BN	5	059-0001
H6	Glenair Special	233-217-G6?23-6BN	6	059-0001
J8	D38999/26FG4SN	233-217-G6?25-8BN	8	059-0001

** Replace ? Material/Finish code from Table I. If unavailable, inquire about 233-105 as alternative.
*** Must order indicated amount for complete plug connector. Contact adapters include respective contacts for each type

050-304 DATASHEET

D38999 Series III Type Active Receptacle Connector
With Glenair Size #8 Opto-Electronic Contacts



Recommended PCB Layout

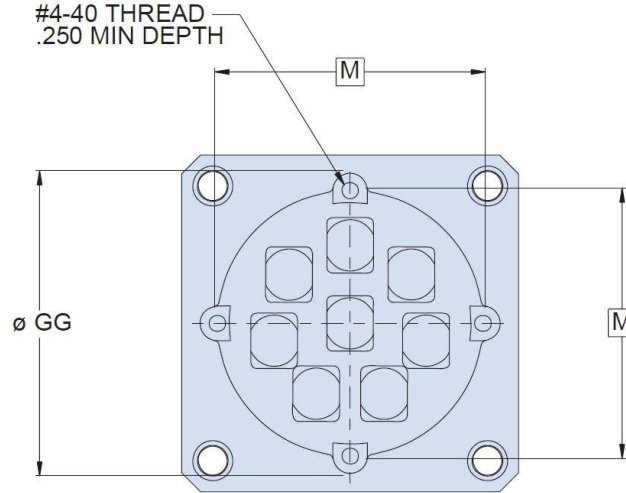

PCB Standoff Locations

Applicable to All Configurations

Table III: Dimensions for PCB Standoff Locations			
Shell Size Code	Shell Size	M basic	Ø GG Max
B	11	.550 (14.0)	.760 (19.3)
E	17	.920 (23.4)	1.130 (28.7)
F	19	1.025 (26.0)	1.235 (31.4)
G	21	1.025 (26.0)	1.235 (31.4)
H	23	1.275 (32.4)	1.485 (37.7)
J	25	1.450 (36.8)	1.600 (42.2)

Table IV: Recommended PCB Hole Sizes for 050-301 and 050-367 Contacts		
	Ø J	Ø L
Solder	.028	.040
Mill-Max*	.039	.060
*Maximum PCB thickness to use Mill-Max contacts is .090" 5X 0566-2-15-15-21-27-10-0 1X 0305-2-15-80-47-27-10-0		

Table IV: Recommended PCB Hole Sizes for 050-399 and 0500-3015 Contacts	
	Ø J
Soldering	.028
Mill-Max*	.039
*Maximum PCB thickness to use Mill-Max contacts is .090" 3X 0305-2-15-80-47-27-10-0	

- 050-399 and 0500-3015 are active size #8 DC-Coupled opto-electronic contacts.
- For electrical ratings and specifications, please refer to 050-301, 050-367, 050-399, and 0500-3015 datasheets.

050-304 DATASHEET

D38999 Series III Type Active Receptacle Connector
With Glenair Size #8 Opto-Electronic Contacts



Recommended PCB Layout (continued)

PCB layouts for different arrangements

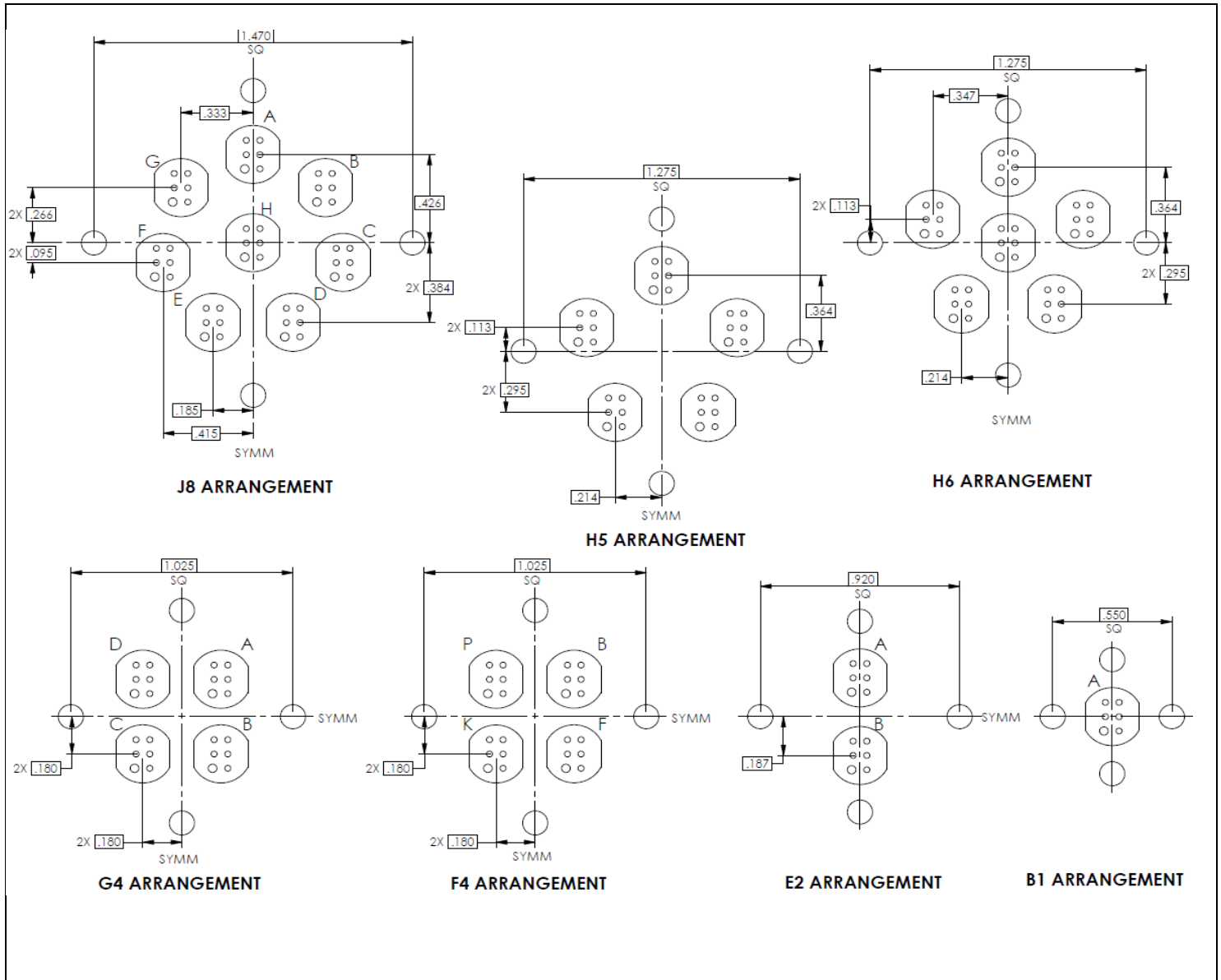

050-304 DATASHEET

D38999 Series III Type Active Receptacle Connector
With Glenair Size #8 Opto-Electronic Contacts



Recommended PCB Layout (continued)

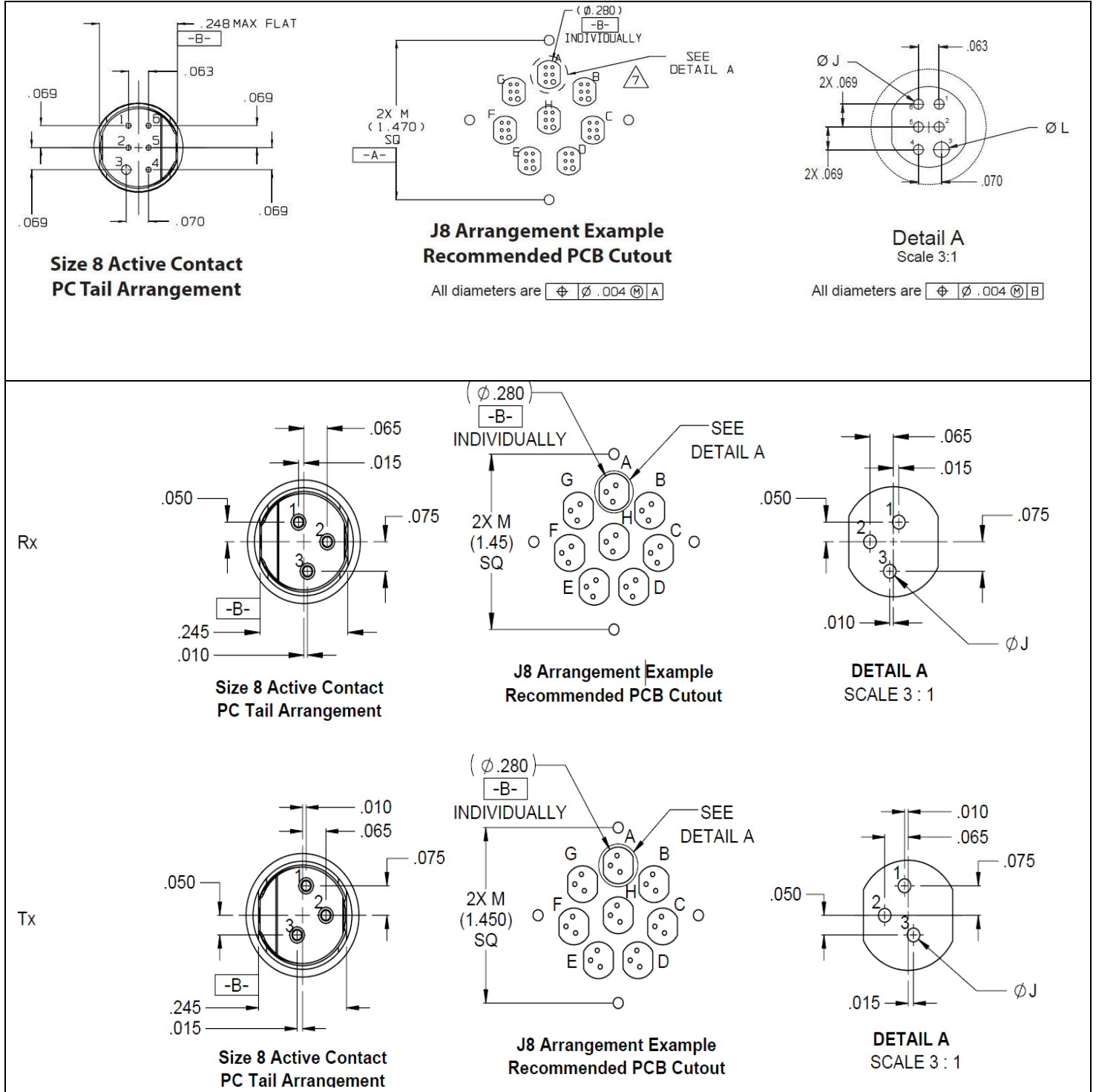

050-304 DATASHEET

D38999 Series III Type Active Receptacle Connector
With Glenair Size #8 Opto-Electronic Contacts



Recommended Inspection & Cleaning Tools/Kits

The following recommendations are suggested for this product:

- GBS-1001 Inspection Kit which includes GIT-003 tip for ARINC 801 fiber contacts.
- GCLT-H200 or GCLT-HA125 cleaning tool for ARINC 801 system.

GBS1001 Inspection Probe with USB Adapter and Fiber Chek 2 Software



How To Order

GBS1001

Basic Part Number Includes:

- *Inspection probe with USB adapter*
- *Fiber Chek 2 Software*

Comes with

(installed on the probe):

GIT-003 Universal 1.25mm patch cord

The GBS1001 is the only inspection probe today with a high resolution, all digital sensor and USB2 video stream which delivers high-resolution uncompressed images directly to your personal computer.

GBS1001 Specifications

Weight	.11 Kg / .25 lb
Resolution	Better than 1.5 Microns
Cable	Integrated USB 2.0 coil cable 2.5' relaxed, 10.5' fully extended
Certification	CE
Warranty	1 year

Fiber Chek Software

Fiber Optic Analysis Program

Fiber Chek is an integrated hardware/software package engineered with the single purpose of critically and consistently grading fiber end-faces. Works hand in hand with the Quick Capture Analog Probe for visual inspection, taking pictures and testing fibers.

- Automatic debris and defect detection, including fine scratches
- Measures epoxy ring for out-of-tolerance conditions
- Inspection results, including image data, can be printed or archived
- Utilizes industry standards or user defined threshold settings

050-304 DATASHEET

D38999 Series III Type Active Receptacle Connector
With Glenair Size #8 Opto-Electronic Contacts



Recommended Inspection & Cleaning Tools/Kits – (Continued)

Dry action cleaning tool for ARINC 801 systems

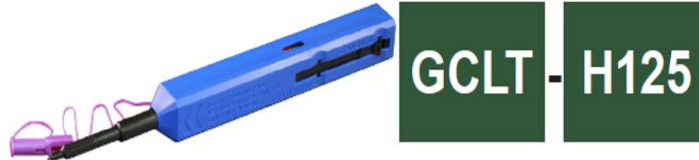

Dry action cleaning tool for ARINC 801 test adapters



- A simple push motion engages tool
- Audible click when tool is fully engaged
- Durable — over 525 engagements per tool
- Crush resistant to over 250N
- Impact resistant to survive drops over 1.5M