



# 050-399

## PRODUCT BRIEF

SIZE 8 ELECTRO-OPTICAL CONTACT TRANSMITTER OR RECEIVER  
DC-10 MBPS, PLUGGABLE  
FRONT INSERT – FRONT RELEASE

REV	DESCRIPTION	DATE	APPROVED
1	Preliminary Draft	01/10/2018	SZ/RS/GC
2	Updated Recommended Host Board Schematic	02/14/2018	SZ/RS/MT
3	Updated ESD rating and outline drawing	08/22/2018	SZ/RZ
4	Add US Patent number on Outline Drawing	09/07/2018	GC
5	Updated pin length on Outline Drawing	09/28/2018	CA
6	Updated pin length/diameter and recommended PCB hole size	10/19/2018	DJM
7	Add 10 Mbps feature. Update Part Nomenclature and EO Characteristics	03/19/2019	JLL/SZ/YA
8	Update Picture and 2D Drawing	11/01/2019	OAE/YA
9	Removed spurious incorrect text. Added units to Table 4 output voltage levels	3/16/2020	RTL/RAS/SZ
10	Update 2D drawing with new ASR and O-ring	7/22/2020	RAS/MG
11	Correct 2D drawing	12/2/2020	NA/RAS

BF17U2-9710

THIS COPYRIGHTED DOCUMENT IS THE PROPERTY OF GLENAIR, INC. AND IS FURNISHED ON THE CONDITION THAT IT IS NOT TO BE DISCLOSED, REPRODUCED IN WHOLE OR IN PART, OR USED TO SOLICIT QUOTATIONS FROM COMPETITIVE SOURCES, OR USED FOR MANUFACTURE BY ANYONE OTHER THAN GLENAIR, INC. WITHOUT WRITTEN PERMISSION FROM GLENAIR, INC. THE INFORMATION HEREIN HAS BEEN DEVELOPED AT GLENAIR'S EXPENSE AND MAY BE USED FOR ENGINEERING EVALUATION AND INCORPORATION INTO TECHNICAL SPECIFICATIONS AND OTHER DOCUMENTS WHICH SPECIFY PROCUREMENT OF PRODUCTS FROM GLENAIR, INC.

## 050-399 PRODUCT BRIEF

SIZE 8 ELECTRO-OPTICAL CONTACT TRANSMITTER OR RECEIVER, MULTI-MODE,  
DC-10 MBPS, 1.25MM FERRULE, ARINC 801  
FRONT INSERT – FRONT RELEASE



### Size 8 Cavity Opto-Electronic Contacts, DC to 10 Mbps, MMF, 3.3V



Size 8 Cavity Opto-electronic contacts transmit and receive TTL/CMOS compatible electrical signals over Multimode fiber optic cable. Transmitters consist of a laser driver and an 850nm VCSEL laser. Receivers consist of an 850nm PIN Photo Detector and an Amplifier. Output data signal is TTL/CMOS compatible.

#### KEY FEATURES/BENEFITS

- Front-release, front-insert, front-removable Size #8 OE converter designed for ARINC 600
- Data rates from DC to 10 Mbps
- Supports RS232, RS422, and RS485 data rates
- DC coupled transmitter and receiver
- Link distances up to 2Km

- Single 3.3V power supply
- ARINC 801 1.25mm ceramic fiber ferrule
- Solutions available in 38999 style connectors
- -40°C to +85°C Operating Case Temperature
- Evaluation fixtures available

#### APPLICATIONS

- Harsh Environment such as: Airborne, Tactical, Railway, Industrial, Oil and Gas and Shipboard applications

#### How To Order

##### Basic Part Number

050-399

##### Optical Device Type

TX = Transmitter

RX = Receiver

01

TX

##### Signal Type

01 = DC- 1 Mbps

02 = DC- 10 Mbps

# 050-399 PRODUCT BRIEF

SIZE 8 ELECTRO-OPTICAL CONTACT TRANSMITTER OR RECEIVER, MULTI-MODE,  
DC-10 MBPS, 1.25MM FERRULE, ARINC 801  
FRONT INSERT – FRONT RELEASE



## Ratings and Specifications

**TABLE 1 ABSOLUTE MAXIMUM RATINGS**

Parameter	Symbol	Min	Typ	Max	Units	Notes
Storage Temperature	T <sub>s</sub>	-55		+100	°C	
Supply Voltage	V <sub>cc</sub>	-0.4		3.8	V	

**TABLE 2 OPERATING CONDITIONS**

Parameter	Symbol	Min	Typ	Max	Units	Notes
Operating Temperature, Case	T <sub>op</sub>	-40		+85	°C	
Supply Voltage	V <sub>cc</sub>	3.135	3.3	3.465	V	
Supply Current	I <sub>cc</sub>			30	mA	Typical @ +85°C
Power Supply Noise (Peak-Peak)	V <sub>cc, ripple</sub>			150	mV	

**TABLE 3 ELECTRO-OPTICAL CHARACTERISTICS – TRANSMITTER**

Parameter	Symbol	Min	Typ	Max	Units	Notes
Optical Output Power	P <sub>OUT</sub>	-8		0	dBm	850nm VCSEL, -40C to +85C
Optical Wavelength	λ <sub>OUT</sub>	830	850	860	nm	
Spectral Width, rms	Δλ			0.85	nm	
High-Level Input Voltage	V <sub>IH</sub>	0.7 V <sub>cc</sub>			V	
Low-Level Input Voltage	V <sub>IL</sub>			0.3 V <sub>cc</sub>	V	

**TABLE 4 ELECTRO-OPTICAL CHARACTERISTICS - RECEIVER**

Parameter	Symbol	Min	Typ	Max	Units	Notes
Sensitivity, BER 10 <sup>-9</sup> , PRBS 2 <sup>7</sup> -1	P <sub>IN</sub>			-22	dBm	PIN PD @ 1 Mbps
Sensitivity, BER 10 <sup>-9</sup> , PRBS 2 <sup>7</sup> -1	P <sub>IN</sub>			-11	dBm	PIN PD @ 10 Mbps
Overload, BER 10 <sup>-9</sup> , PRBS 2 <sup>7</sup> -1	P <sub>IN</sub>	-3			dBm	
Optical Wavelength	λ <sub>IN</sub>	830		860	nm	
Output Voltage High	V <sub>OH</sub>	V <sub>cc</sub> -0.4			V	
Output Voltage Low	V <sub>OL</sub>			0.4	V	

**TABLE 5 COMPLIANCE SPECIFICATIONS**

CHARACTERISTIC	Standard	Condition	Notes
ESD	IEC61000-4-2		15KV (air), 12KV (contact)
Eye Safety	CDRH and IEC-825	Class 1 Laser Product	

## 050-399 PRODUCT BRIEF

SIZE 8 ELECTRO-OPTICAL CONTACT TRANSMITTER OR RECEIVER, MULTI-MODE,  
DC-10 MBPS, 1.25MM FERRULE, ARINC 801  
FRONT INSERT – FRONT RELEASE



### *Input/Output Definition*

**TABLE 6 TRANSMITTER ELECTRICAL PIN ARRANGEMENT**

Pin Number	Symbol	Description	Logic
1	Vcc	Power Supply	
2	GND	Signal Ground	
3	TXIN	Transmitter Data (Input)	TTL/CMOS

**TABLE 7 RECEIVER ELECTRICAL PIN ARRANGEMENT**

Pin Number	Symbol	Description	Logic
1	Vcc	Power Supply	
2	GND	Signal Ground	
3	RXOUT	Receiver Data (Output)	TTL/CMOS

## 050-399 PRODUCT BRIEF

SIZE 8 ELECTRO-OPTICAL CONTACT TRANSMITTER OR RECEIVER, MULTI-MODE,  
DC-10 MBPS, 1.25MM FERRULE, ARINC 801  
FRONT INSERT – FRONT RELEASE



### FIGURE 1 - OUTLINE DRAWING

Refer to datasheet for more details

#### LABELING:

Each unit will be shipped in an antistatic bag. The label on the antistatic bag shall be at a minimum Arial size 10 black font and contain at a minimum the following information:

#### ANTISTATIC BAG LABEL:

Glenair

Cage Code: 06324

PN: 050-399-XX-XX

Rev: X

QTY: X

J/N: X

D/C:X

S/N\*: XXXXXX

\*If QTY is more than 1, there is no S/N

# 050-399 PRODUCT BRIEF

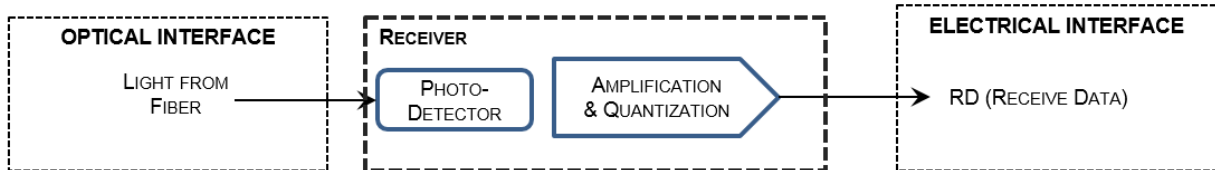
SIZE 8 ELECTRO-OPTICAL CONTACT TRANSMITTER OR RECEIVER, MULTI-MODE,  
DC-10 MBPS, 1.25MM FERRULE, ARINC 801  
FRONT INSERT – FRONT RELEASE



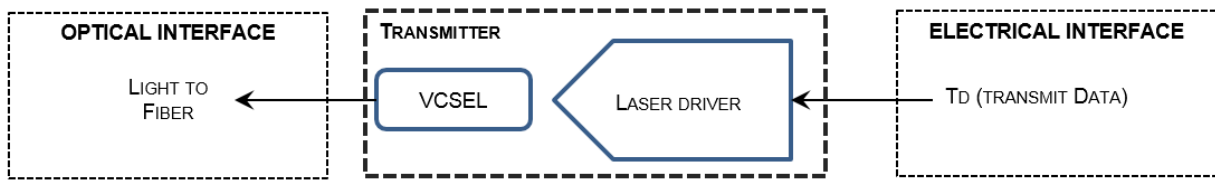
## FUNCTIONAL DESCRIPTION

Figure 2

### Receiver Functional Block Diagram



### Transmitter Functional Block Diagram



## FUNCTIONAL I/O

The Size 8 transmitter accepts industry standard TTL/CMOS signals. The module is DC-coupled internally.

Figure 3 illustrates a recommended interface circuit to link the Size 8 transmitter and receiver to the supporting Physical Layer integrated circuits.

The Size 8 transmitter or receiver interfaces with the host circuit board through 3 I/O pins identified by function in Table 7.

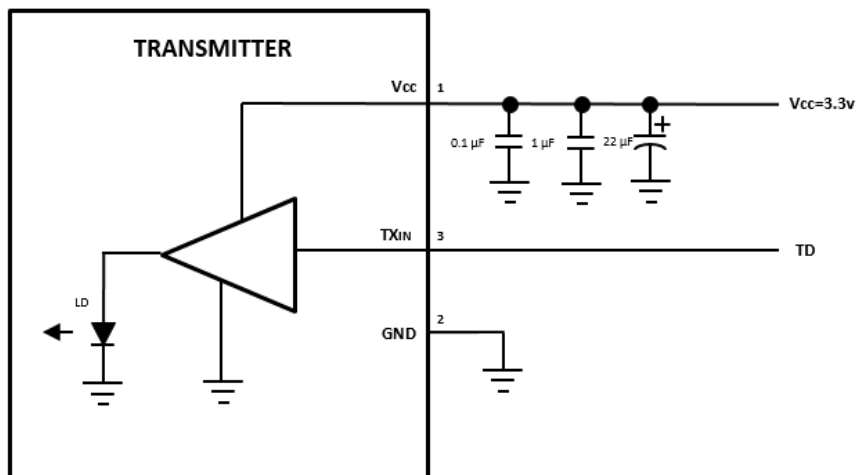
# 050-399 PRODUCT BRIEF

SIZE 8 ELECTRO-OPTICAL CONTACT TRANSMITTER OR RECEIVER, MULTI-MODE,  
DC-10 MBPS, 1.25MM FERRULE, ARINC 801  
FRONT INSERT – FRONT RELEASE

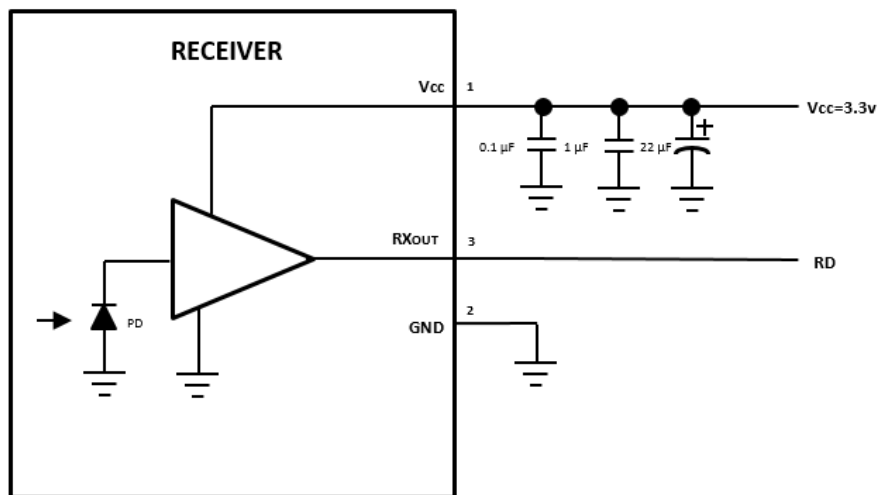


FIGURE 3 RECOMMENDED BOARD HOST BOARD SCHEMATIC

## RECOMMENDED INTERFACE CIRCUIT



## RECOMMENDED INTERFACE CIRCUIT



## 050-399 PRODUCT BRIEF

SIZE 8 ELECTRO-OPTICAL CONTACT TRANSMITTER OR RECEIVER, MULTI-MODE,  
DC-10 MBPS, 1.25MM FERRULE, ARINC 801  
FRONT INSERT – FRONT RELEASE



### Required Host Board Components

A power supply noise rejection filter as described in Figure 3 is required on the host PCB to meet data sheet performance. The required filter is illustrated in Figure 3.

### Fiber Compatibility

The link is capable of error free signal detection for 2 to 2000 meters with OM2 50/125  $\mu$ m fiber or with OM1 62.5/ 125  $\mu$ m fiber.

### Electrostatic Discharge (ESD)

The size 8 contacts are compatible with ESD levels found in typical manufacturing and operating environments as described JEDEC EIA JESD22-A114-A, Class 1C (<2000Volts) HBM. Glenair recommends that devices are handled with ESD precautions to limit exposure to below 500V HBM.

There are two design cases in which immunity to ESD damage is important. The first case is during handling of the components prior to insertion to the host board. It is important to use standard industry ESD handling precautions such as using grounded wrist straps, work benches, and floor mats in ESD controlled areas. The ESD sensitivity of the Glenair device is compatible with typical industry production environments.

The second case to consider is static discharges to the exterior of the host equipment after installation, in which case the electro-optical component may be subject to system-level ESD requirements.

### Application Support

To assist in the transmitter and receiver design and evaluation process, Glenair offers the following aids:

- Evaluation board & Product Manual
- 3D Step file to support modeling of mechanical fit and routing