



This document contains technology whose U.S. export is restricted and/or controlled by the U.S. Export Administration Regulations (15CFR parts 730-774). This technology may not be exported, disclosed or retransferred to any foreign person without U.S. Department of Commerce licensing authority." Technology is ECCN 5E991

0500-3064

PRODUCT BRIEF

SIZE 8 ELECTRO-OPTICAL CONTACT TRANSMITTER OR RECEIVER
LOW OUTGASSING FOR SPACE APPLICATIONS
MULTI-MODE, 1.25MM FERRULE ARINC 801
FRONT INSERT – FRONT RELEASE

REV	DESCRIPTION	DATE	APPROVED
1	Preliminary	02/16/2022	RAS/SS/NA/MET
2	Updated 2D drawing to correct part number on label	02/18/2022	NA/SS
3	Updated picture	04/12/2022	MET

BF22U2-XXXX

THIS COPYRIGHTED DOCUMENT IS THE PROPERTY OF GLENAIR, INC. AND IS FURNISHED ON THE CONDITION THAT IT IS NOT TO BE DISCLOSED, REPRODUCED IN WHOLE OR IN PART, OR USED TO SOLICIT QUOTATIONS FROM COMPETITIVE SOURCES, OR USED FOR MANUFACTURE BY ANYONE OTHER THAN GLENAIR, INC. WITHOUT WRITTEN PERMISSION FROM GLENAIR, INC. THE INFORMATION HEREIN HAS BEEN DEVELOPED AT GLENAIR'S EXPENSE AND MAY BE USED FOR ENGINEERING EVALUATION AND INCORPORATION INTO TECHNICAL SPECIFICATIONS AND OTHER DOCUMENTS WHICH SPECIFY PROCUREMENT OF PRODUCTS FROM GLENAIR, INC.

0500-3064 Product Brief

SIZE 8 ELECTRO-OPTICAL CONTACT TRANSMITTER OR RECEIVER, MULTI-MODE,
1.25MM FERRULE, ARINC 801, LOW OUTGASSING FOR SPACE APPLICATIONS
FRONT INSERT – FRONT RELEASE



Size 8 Cavity Opto-Electronic Contacts, 100Mbps to 5.00Gbps, MMF, 3.3V

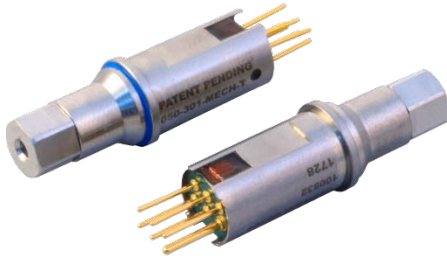

The 0500-3064 Size 8 Cavity Opto-electronic contacts, a derivative of Glenair 050-301, transmit and receive differential CML electrical signals over Multimode fiber optic cable. Transmitters consist of a laser driver with a temperature compensation circuit to maintain optical power over the entire operating temperature range, and an 850nm VCSEL laser. Receivers consist of an 850nm PIN Photo Detector, a Transimpedance Amplifier with automatic gain control circuit, and a Limiting Amplifier. Differential output data signals are CML compatible. The transmitter has a Tx Disable pin to turn off transmitter output and a Tx Fault pin to signal a fault condition. Receiver includes a CMOS compatible Loss of Signal Indicator to prevent invalid data.

U.S. Patent# US9297972, US9946041

The 0500-3064 is designed for space applications. The materials used have been reviewed and updated for space applications, include low outgassing compliance; however, the screening and assembly processes are aerospace grade. Radiation Effects test report is available under NDA.

KEY FEATURES/BENEFITS

- Front-release, front-insert, front-removable Size #8 OE converter designed for ARINC 600
- ARINC 664, 801, 803, 804, and 818 Standard Compliant
- Data rates from 100Mbps to 5.00Gbps
- Supports Fast and Gigabit Ethernet, AFDX, 1x/2x Fibre Channel, DVI, DHMI, SFPDP, Serial Rapid I/O (sRIO)
- 100 ohms differential CML inputs with Tx Fault and Tx Disable
- Link distances up to 550 meters with multimode 50/125µm or 62.5/125 µm fiber
- Single 3.3V power supply
- ARINC 801 1.25mm ceramic fiber ferrule
- Outgassing compliant to ASTM E595
- Solutions available in 38999 style connectors
- -40°C to +85°C Operating Case Temperature
- Evaluation fixtures available
- (Option for aerospace-grade version. See DS050-301)

APPLICATIONS

- Harsh Environment such as: Airborne, Tactical, Railway, Industrial, Oil and Gas, and Shipboard applications

How To Order

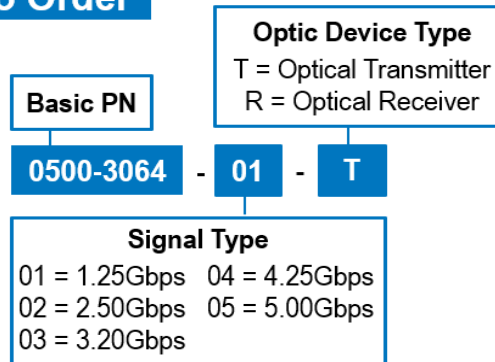

0500-3064 Product Brief

SIZE 8 ELECTRO-OPTICAL CONTACT TRANSMITTER OR RECEIVER, MULTI-MODE,
1.25MM FERRULE, ARINC 801, LOW OUTGASSING FOR SPACE APPLICATIONS
FRONT INSERT – FRONT RELEASE



Ratings and Specifications

TABLE 2 ABSOLUTE MAXIMUM RATINGS

Parameter	Symbol	Min	Typ	Max	Units	Notes
Storage Temperature	T _s	-55		+100	°C	
Supply Voltage	V _{cc}	-0.4		3.8	V	

TABLE 3 OPERATING CONDITIONS

Parameter	Symbol	Min	Typ	Max	Units	Notes
Operating Temperature, Case	T _{op}	-40		+85	°C	
Supply Voltage	V _{cc}	3.135	3.3	3.465	V	
Supply Current	I _{cc}			100	mA	Typical @ +85°C
Power Supply Noise (Peak-Peak)	V _{cc_ripple}			150	mV	

TABLE 4 ELECTRO-OPTICAL CHARACTERISTICS – TRANSMITTER

Parameter	Symbol	Min	Typ	Max	Units	Notes
Optical Output Power	P _{OUT}	-6.5		-1.5	dBm	850nm VCSEL,
Extinction Ratio	E _r	6	10		dB	1.25 Gbps
Optical Wavelength	λ _{OUT}	830	850	860	nm	
Spectral Width, rms	Δλ			0.85	nm	
Total Jitter	T _{J_p-p}			60	ps	
Transmitter Differential Input Impedance	Z _{in}		100		Ohms	Requires external AC coupling on customer's board
Differential Input Voltage	V _{in_d}	250		2200	mV _{p-p}	CML, 100 ohm

TABLE 5 ELECTRO-OPTICAL CHARACTERISTICS - RECEIVER

Parameter	Symbol	Min	Typ	Max	Units	Notes
Sensitivity, BER 10 ⁻¹² , PRBS 2 ⁷ -1, E _r 9 dB	P _{IN}			-17	dBm	PIN PD @ .125 Gbps
Sensitivity, BER 10 ⁻¹² , PRBS 2 ⁷ -1, E _r 9 dB	P _{IN}			-17	dBm	PIN PD @ 1.25 Gbps
Overload, BER 10 ⁻¹² , PRBS 2 ⁷ -1	P _{IN}			0	dBm	
Optical Wavelength	λ _{IN}	830		860	nm	
Receiver Differential Output Impedance	Z _{out}		100		Ohms	Requires external AC coupling on customer's board
Differential Output Voltage Swing	V _{out_d}	600		1200	mV _{p-p}	CML, 100 ohm
LOS Assert Level	LOS			-20	dBm	@ 1.25 Gbps
LOS Hysteresis	LOS _{HYS}	1.5	2.3		dB	@ 1.25 Gbps

TABLE 6 COMPLIANCE SPECIFICATIONS

CHARACTERISTIC	Standard	Condition	Notes
ESD	MIL-STD-883		1000V HBM
Eye Safety	CDRH and IEC-825	Class 1 Laser Product	

0500-3064 Product Brief

SIZE 8 ELECTRO-OPTICAL CONTACT TRANSMITTER OR RECEIVER, MULTI-MODE,
1.25MM FERRULE, ARINC 801, LOW OUTGASSING FOR SPACE APPLICATIONS
FRONT INSERT – FRONT RELEASE



Input/Output Definition

See datasheet for details

TABLE 7 TRANSMITTER ELECTRICAL PIN ARRANGEMENT

TABLE 8 RECEIVER ELECTRICAL PIN ARRANGEMENT

0500-3064 Product Brief

SIZE 8 ELECTRO-OPTICAL CONTACT TRANSMITTER OR RECEIVER, MULTI-MODE,
1.25MM FERRULE, ARINC 801, LOW OUTGASSING FOR SPACE APPLICATIONS
FRONT INSERT – FRONT RELEASE



FIGURE 1 - OUTLINE DRAWING

See datasheet for additional details

0500-3064 Product Brief

SIZE 8 ELECTRO-OPTICAL CONTACT TRANSMITTER OR RECEIVER, MULTI-MODE,
1.25MM FERRULE, ARINC 801, LOW OUTGASSING FOR SPACE APPLICATIONS
FRONT INSERT – FRONT RELEASE



FUNCTIONAL DESCRIPTION

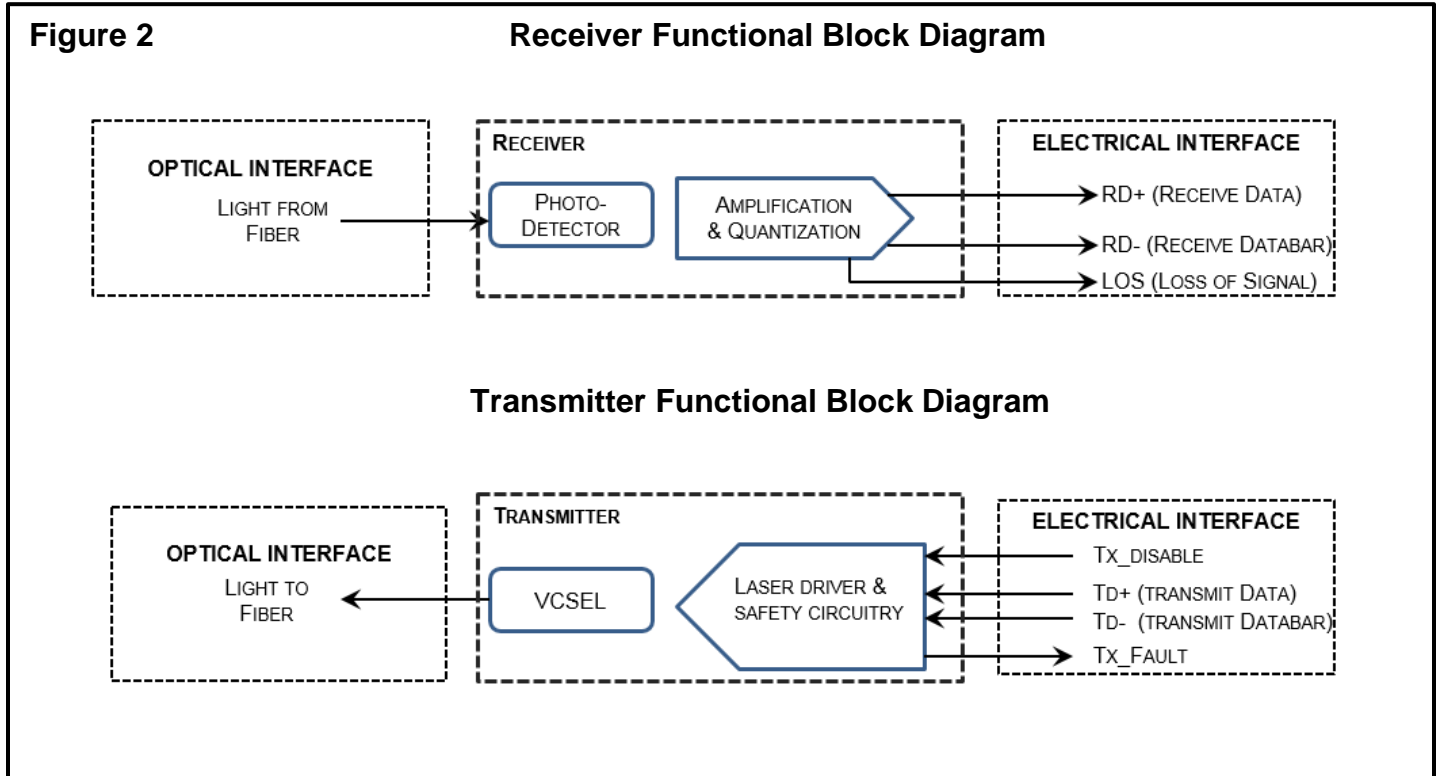

FUNCTIONAL I/O

The Size 8 transmitter accepts industry standard CML differential signals within the scope of the SFP MSA. The module is DC-coupled and internally terminated.

Figure 3 illustrates a recommended interface circuit to link the Size 8 transmitter and receiver to the supporting Physical Layer integrated circuits.

The Size 8 transmitter or receiver interfaces with the host circuit board through six I/O pins identified by function in Table 7. The transmitter high speed transmit and the receiver high speed receive interfaces require SFP MSA compliant signal lines on the host board. The TX_DISABLE and TX_FAULT require TTL lines on the host board (per SFF-8074i) if used. If an application chooses not to take advantage of the functionality of these pins TX_Disable needs to be tied to GND, and TX_Fault does not need to be connected.

0500-3064 Product Brief

SIZE 8 ELECTRO-OPTICAL CONTACT TRANSMITTER OR RECEIVER, MULTI-MODE,
1.25MM FERRULE, ARINC 801, LOW OUTGASSING FOR SPACE APPLICATIONS
FRONT INSERT – FRONT RELEASE



FIGURE 3 RECOMMENDED BOARD HOST BOARD SCHEMATIC

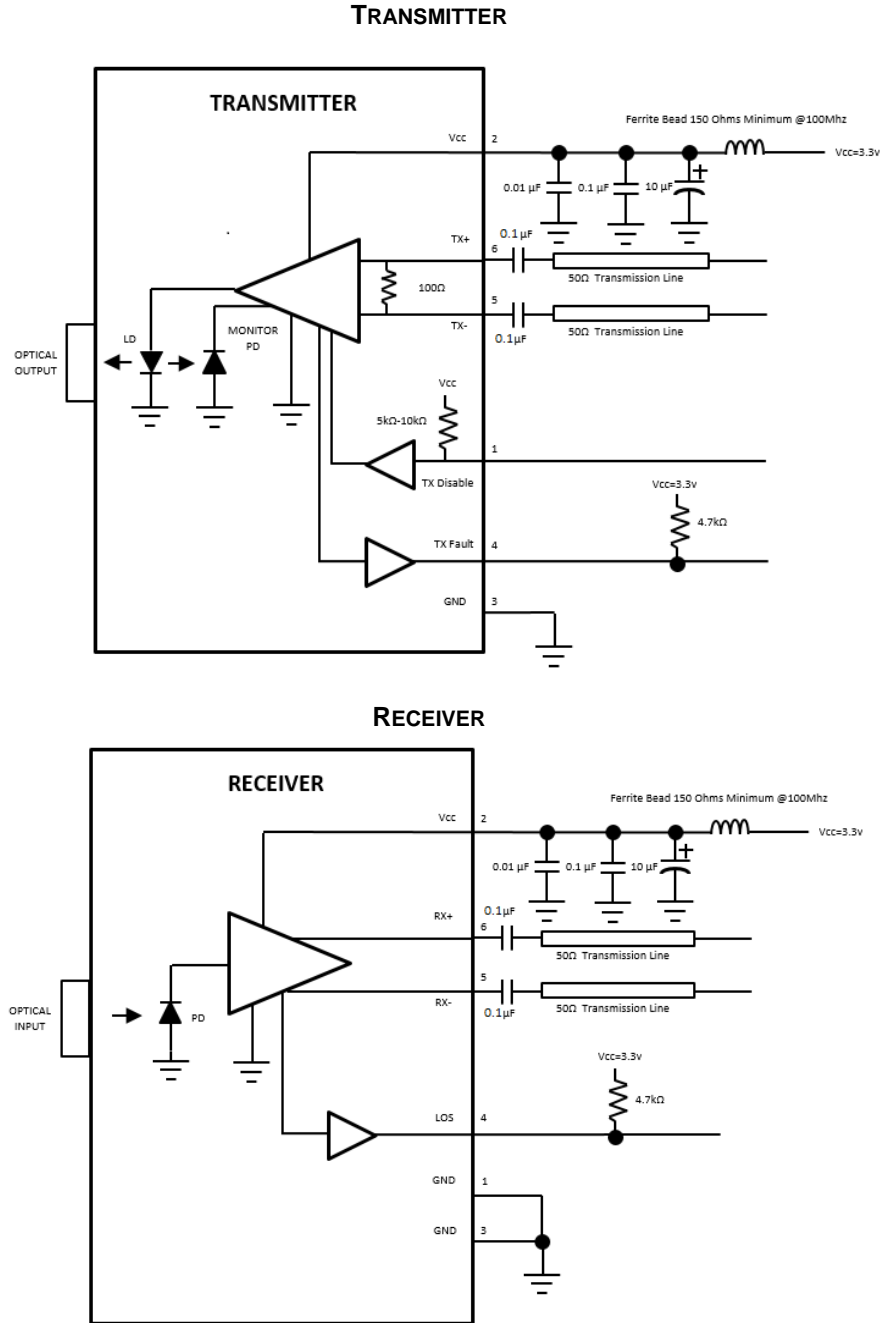

0500-3064 Product Brief

SIZE 8 ELECTRO-OPTICAL CONTACT TRANSMITTER OR RECEIVER, MULTI-MODE,
1.25MM FERRULE, ARINC 801, LOW OUTGASSING FOR SPACE APPLICATIONS
FRONT INSERT – FRONT RELEASE



Required Host Board Components

A power supply noise rejection filter as described in Figure 3 is required on the host PCB to meet data sheet performance. The required filter is illustrated in Figure 3. Also, the host PCB for the Size 8 transmitter requires 4.7 K to 10 K Ω pull-up resistors for TX_FAULT and LOS Lines for the receiver.

Fiber Compatibility

The link is capable of error free signal detection for 2 to 500 meters with OM2 50/125 μm fiber and at 2 to 275 meters with OM1 62.5/ 125 μm fiber, for 1.25 - 5.00 Gbps data rate.

Electrostatic Discharge (ESD)

The size 8 contacts are compatible with ESD levels found in typical manufacturing and operating environments as described JEDEC EIA JESD22-A114-A, Class 1C (<2000Volts) HBM. Glenair recommends that devices are handled with ESD precautions to limit exposure to below 500V HBM.

There are two design cases in which immunity to ESD damage is important. The first case is during handling of the components prior to insertion to the host board. It is important to use standard industry ESD handling precautions such as using grounded wrist straps, work benches, and floor mats in ESD controlled areas. The ESD sensitivity of the Glenair device is compatible with typical industry production environments.

The second case to consider is static discharges to the exterior of the host equipment after installation, in which case the electro-optical component may be subject to system-level ESD requirements.

Application Support

To assist in the dual-transmitter design and evaluation process, Glenair offers the following aids:

- Evaluation board & Product Manual
- 3D Step file to support modeling of mechanical fit and routing