



050-336

PRODUCT BRIEF

100 MBPS-5 GBPS

PRINTED CIRCUIT BOARD (PCB) MOUNT QUAD TRANSMITTER

850NM VCSEL TRANSMITTER

SMALL & COMPACT WITH RUGGED CONSTRUCTION FOR
HARSH ENVIRONMENTS

REV	DESCRIPTION	DATE	APPROVED
A	Initial Release	07/01/2015	SZ
B	Per DCN60359; Add ECCN	05/26/2016	RAS
C	Per DCN61188; Update height of transceiver	07/27/2016	SZ/GC
D	Per DCN62625; Replace "mm" with "um" on I2C table	11/10/2016	SZ/GC
E	Per DCN62947; Edit Bag and Tag Labeling	12/05/2016	RS/GC
F	Per DCN63730; Remove incorrect reference to ATMEL AT240C01A, added optional I2C addressing	02/24/2017	SZ/RAS/GC
G	Per DCN64107; Remove "954A-xxx" screw length mod code	03/02/2017	RAS/GC
H	Per DCN64356; Change ER for 4.25 and 5 Gbps to 5dB	03/17/2017	SZ/GC

BF14U2-7076

THIS COPYRIGHTED DOCUMENT IS THE PROPERTY OF GLENAIR, INC. AND IS FURNISHED ON THE CONDITION THAT IT IS NOT TO BE DISCLOSED, REPRODUCED IN WHOLE OR IN PART, OR USED TO SOLICIT QUOTATIONS FROM COMPETITIVE SOURCES, OR USED FOR MANUFACTURE BY ANYONE OTHER THAN GLENAIR, INC. WITHOUT WRITTEN PERMISSION FROM GLENAIR, INC. THE INFORMATION HEREIN HAS BEEN DEVELOPED AT GLENAIR'S EXPENSE AND MAY BE USED FOR ENGINEERING EVALUATION AND INCORPORATION INTO TECHNICAL SPECIFICATIONS AND OTHER DOCUMENTS WHICH SPECIFY PROCUREMENT OF PRODUCTS FROM GLENAIR, INC.

050-336 PRODUCT BRIEF
PCB Mount Quad Transmitter
100 Mbps – 5 Gbps, MMF, 3.3V



PCB Mount Fiber Optic Quad Transmitter, 100M-5Gbps, MMF, 3.3V

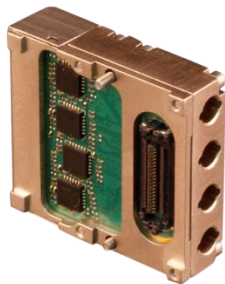

Glenair 050-336, is a ruggedized harsh environment PCB mount Quad Transmitter module with electrical and optical functionality equivalent to SFP transmitter but with mechanical design that is suited to the harsh temperature and vibration environments found in Military, Aerospace, Railway, Oil and Gas, and Industrial applications. The PCB mount optical transmitter also supports optional Digital Monitoring Interface (DMI) features in accordance with SFF 8472. The unit is comprised of four transmitter sections that resides on a common package platform and interface with a host board through a high speed electrical connector.

Each transmitter section includes a Transmitter Optical Subassembly (TOSA) and laser driver circuitry. The TOSA, containing an 850 nm VCSEL (Vertical Cavity Surface Emitting Laser) light source, is located at the optical interface and mates with an ARINC 801 optical connector. The TOSA is driven by a laser driver, which converts differential CML logic signals into an analog laser diode drive current. This laser driver circuit regulates the optical power at a constant level provided the data pattern is DC balanced (for example 8B10B encoding).

KEY FEATURES/BENEFITS

- SFP Compatible Electrical I/O signal levels
- 850nm VCSEL lasers to support up to 5 Gbps
- ARINC 801 optical contacts
- Easy assembly - module is securely mounted with screws from the top to PCB to ensure excellent shock and vibration performance
- High-Speed Electrical plug-in connector eliminates the need for soldering & enables ease of servicing
- Compact Size: 1.1" x1" x 0.39"
- -40°C to +85°C Operating Case Temperature
- Glenair fiber jumpers connect from the transmitter to any Glenair Mil/Aero Fiber Optic Connector Style
- Evaluation fixtures available
- Digital Diagnostic and Monitoring (DMI) based on SFF-8472, enables monitoring of:
 - TX optical power, Laser bias current, Temperature, Supply voltage

APPLICATIONS

- Harsh Environment such as: Airborne, Tactical, Railway, Industrial, Oil and Gas and Shipboard applications
 - Ethernet, Fibrechannel, 1x, 2x, 4x, SFPDP

HOW TO ORDER **Table 1 Part Number Development Options**

Part Number	Two Wire Address	Data Rate	Temperature	Screw Length** (Mod Code)
050-336	Blank = A2h, A4h, A6h, A8h	-1-D = 100 Mbps - 2.5 Gbps	Blank = Standard	Blank = Standard
PCB Mount Quad-Transmitter, MMF, 850nm 0.1-5 Gbps	Other Options: See Table 1A	-2-D = 2.5 Gbps - 5 Gbps		-954-xxx = IAW Mod Code 954

Example: **050-336C2-1-D**

PCB Mount Quad-Transmitter, MMF, 850nm, Two Wire ID Address = C2h C4h C6h C8h, Data Rate = 100 Mbps – 2.5Gbps, Standard Temperature Range, Standard Screw Length

**Temperature and Screw Length Mod Codes will not be added onto Digital Memory ID (See Table 8)

**050-336 PRODUCT BRIEF
PCB Mount Quad Transmitter
100 Mbps – 5 Gbps, MMF, 3.3V**



TABLE 1A TWO WIRE ADDRESS –IDENTIFIER OPTIONS

PN Identifier	Transmitter #1 Address	Transmitter #2 Address	Transmitter #3 Address	Transmitter #4 Address
Blank	A2h	A4h	A6h	A8h
B2	B2h	B4h	B6h	B8h
C2	C2h	C4h	C6h	C8h
D2	D2h	D4h	D6h	D8h
E2	E2h	E4h	E6h	E8h
X1	12h	14h	16h	18h
X2	22h	24h	26h	28h
X3	32h	34h	36h	38h
X4	42h	44h	46h	48h
X5	52h	54h	56h	58h
X6	62h	64h	66h	68h
X7	72h	74h	76h	78h
X8	82h	84h	86h	89h
X9	92h	94h	96h	98h

**Contact Glenair if additional addresses required*

050-336 PRODUCT BRIEF
PCB Mount Quad Transmitter
100 Mbps – 5 Gbps, MMF, 3.3V



Ratings and Specifications

TABLE 2 ABSOLUTE MAXIMUM RATINGS

Parameter	Symbol	Min	Typ	Max	Units	Notes
Storage Temperature	T _s	-55		+100	°C	
Supply Voltage	V _{cc}	-0.4		3.8	V	V _{cc} may not differ by more than 0.5V

TABLE 3 OPERATING CONDITIONS

Parameter	Symbol	Min	Typ	Max	Units	Notes
Operating Temperature, Case	T _{op}	-40		+85	°C	
Supply Voltage	V _{cc}	3.135	3.3	3.465	V	
Supply Current	I _{cc}		360	400	mA	Typical @ +85°C
Power Supply Noise (Peak-Peak)	V _{cc, ripple}			100	mV	

TABLE 4 ELECTRO-OPTICAL CHARACTERISTICS

Parameter	Symbol	Min	Typ	Max	Units	Notes
Optical Output Power	P _{OUT}	-6.5	-5	-1	dBm	850nm VCSEL
Extinction Ratio, 1.25Gbps	E _r	7	10		dB	Exceeds OMA for GbE, 1FC
Extinction Ratio, 2.125 Gbps & 3.2 Gbps	E _r	6			dB	Exceeds OMA for 2FC
Extinction Ratio, 4.25 Gbps & 5 Gbps	E _r	5			dB	Exceeds OMA for 4FC
Optical Wavelength	λ _{OUT}	830	850	860	nm	
Spectral Width, rms	Δλ			0.85	nm	
Relative Intensity Noise	RIN			-117	dB/Hz	
Transmitter Differential Input Impedance	R _{in}		100		Ohms	AC coupled Internally
Differential Input Voltage	V _{in_d}	250		2200	mV _{p-p}	CML, 100 ohm

TABLE 5 COMPLIANCE SPECIFICATIONS

CHARACTERISTIC	Standard	Condition	Notes
Mechanical Shock	MIL-STD-810	Para. 516.6, proc. I, 650g	0.9 ms operating
Mechanical Vibration	MIL-STD-810	Para. 514.6, 40g rms	Random, operating
ESD	MIL-STD-883		500V HBM
Flame Resistance	MIL-STD-1344	Method 1012, Cond. B	30 seconds
Damp Heat	MIL-STD-1344	Method 1002.2, Cond. B	10 cycles , 24 hours
Eye Safety	CDRH and IEC-825	Class 1 Laser Product	

**050-336 PRODUCT BRIEF
PCB Mount Quad Transmitter
100 Mbps – 5 Gbps, MMF, 3.3V**



Ratings and Specifications (continued)

TABLE 6 MATERIAL/FINISH

Item	Material/Finish
PCB	FR4
PCB flex	FR4 & Polyimide
Railings	Aluminum 6061-T6 per ASTM-B221/B211M or Equivalent
Screws	CRES Type, 302, 303, 304, 305, or 316
Optical Ferrules & Sleeves	Zirconia, Ceramic
Solder type	RoHS compliant Sn95/Sb5 (232°C melting temp) & RoHS compliant Sn96.5/Ag3.0/Cu0.5 (217° melting)

**050-336 PRODUCT BRIEF
PCB Mount Quad Transmitter
100 Mbps – 5 Gbps, MMF, 3.3V**



FIGURE 2 - OUTLINE DRAWING (cont'd)
LABELING:

Each unit will be shipped in an antistatic bag. The label on the antistatic bag shall in Arial size 10 black font and contain the following information:

ANTISTATIC BAG LABEL:

Glenair

Cage Code: 06324

PN: 050-336XX-X-X

Rev: X

QTY: X

J/N: X

D/C:X

S/N*: XXXXXX

*If QTY is more than 1, there is no S/N

Each unit will be marked as follows:

- Marking:
 - Glenair
 - Part Number
 - Serial Number (6 digits)

FUNCTIONAL DESCRIPTION

FIGURE 2 - BLOCK DIAGRAM – QUAD TRANSMITTER

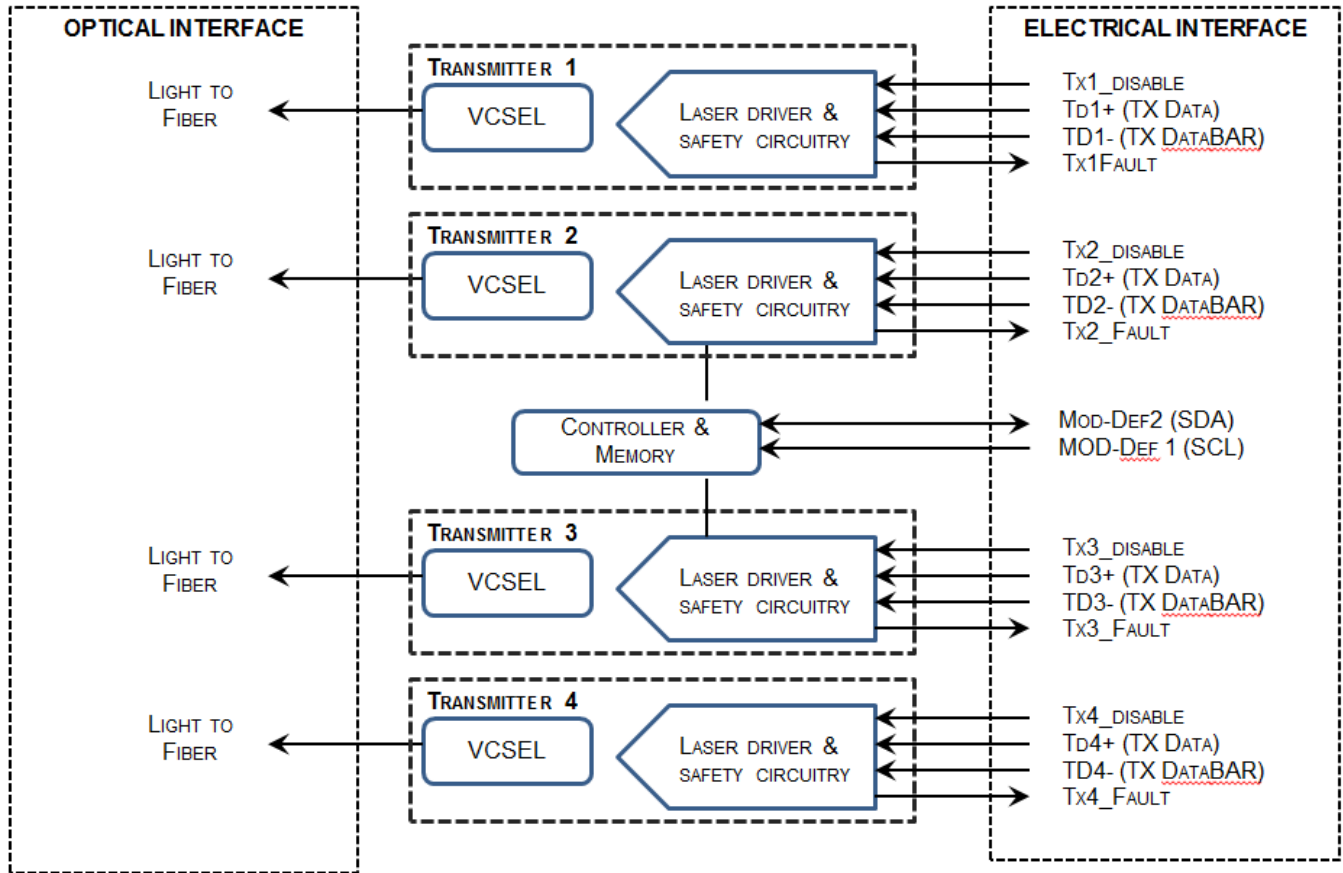

TRANSMITTER SECTION

Transmit Enable (TX Enable)

The transmitter section accepts a TTL and CMOS compatible transmit enable control signal input that turns on the transmitter optical output. A high signal disables the transmitter while a low signal allows normal transmitter operation. Also laser is disabled when TX Enable is open. In the event of a fault (e.g. eye safety circuit activated), cycling this control signal resets the module. Host systems should allow a 10ms interval between successive assertions of this control signal.

Transmit Fault (Tx Fault)

A catastrophic laser fault will activate the transmitter signal, TX FAULT, and disable the laser. This signal is an open collector output (pull-up required on the host board). A low signal indicates normal laser operation and a high signal

050-336 PRODUCT BRIEF
PCB Mount Quad Transmitter
100 Mbps – 5 Gbps, MMF, 3.3V



indicates a fault. The TX FAULT will be latched high when a laser fault occurs and is cleared by toggling the TX ENABLE input or cycling the power of the transceiver. The transmitter fault condition can also be monitored via the 2-wire serial interface (address A2, byte 110, bit 2).

Eye Safety Circuit

The Transmitter section provides Class 1 eye safety by design and is compliant with US FDA CDRH AEL Class 1 and EN(IEC) 60825-1,2, EN60950 Class 1. The eye safety circuit continuously monitors optical output power levels and will disable the transmitter and assert a TX_FAULT signal upon detecting an unsafe condition. Such unsafe conditions can be created by inputs from the host board (Vcc fluctuation, unbalanced code) or faults within the module.

FUNCTIONAL I/O

The PCB mount transmitter accepts industry standard differential signals such as LVPECL and CML within the scope of the SFP MSA. To simplify board requirements, transmitter bias resistors and ac coupling capacitors are incorporated, per SFF-8074i, and hence are not required on the host board. The module is AC-coupled and internally terminated.

Figure 3 illustrates a recommended interface circuit to link the PCB mount transmitter to the supporting Physical Layer integrated circuits.

**FIGURE 3 – HOST BOARD RECOMMENDED SCHEMATIC
 SINGLE TRANSMITTER SHOWN (X4 TRANSMITTERS PER MODULE)**

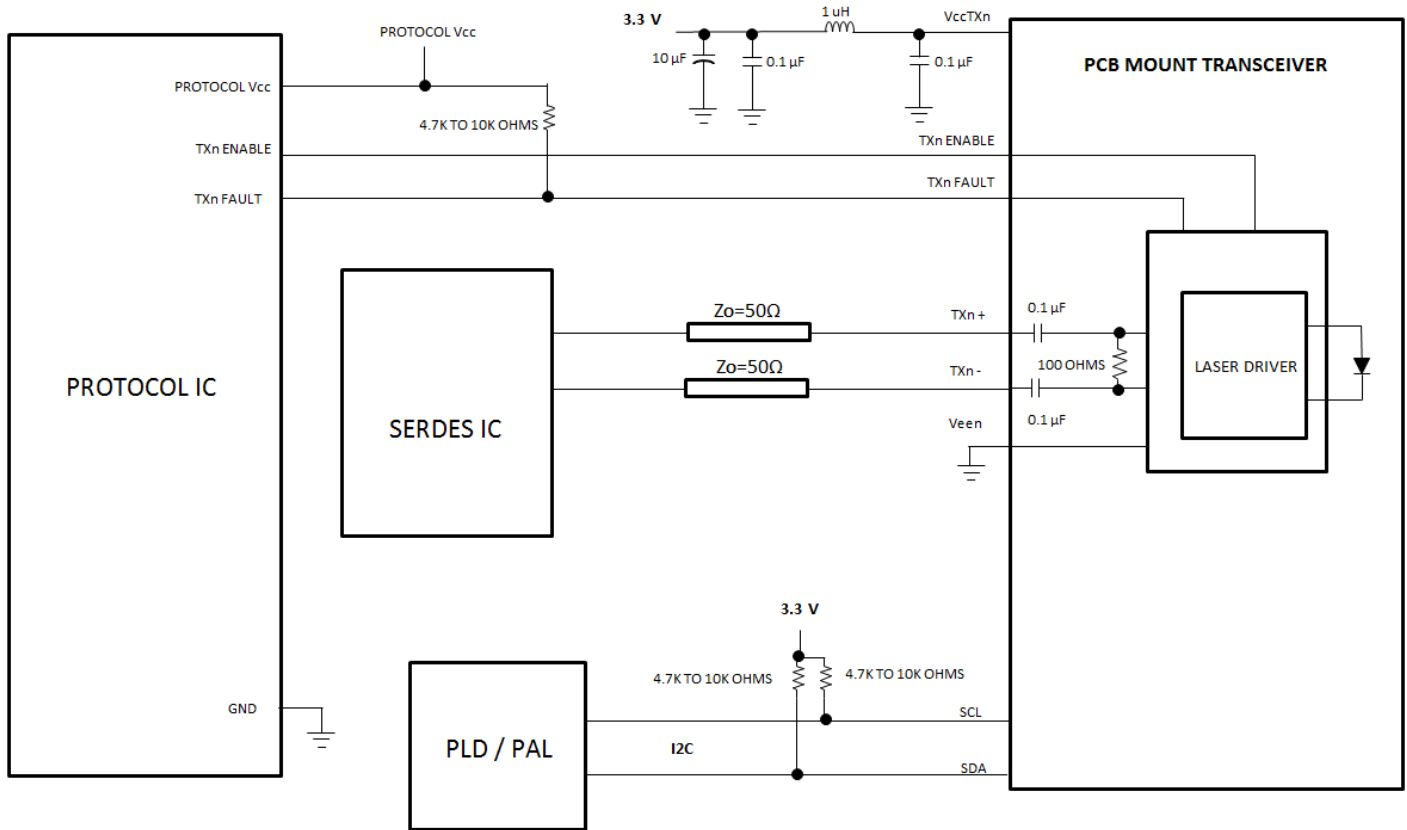

The PCB mount transmitter interfaces with the host circuit board through forty I/O pins identified by function in Table 7. The high speed signal interfaces require SFP MSA compliant signal lines on the host board. The TX Enable and TX Fault, lines require TTL lines on the host board (per SFF-8074i) if used. If an application chooses not to take advantage of the functionality of these pins, TX1_Enable, TX2_Enable, TX3_Enable and TX4_Enable need to be tied to GND, TX1_Fault, TX2_Fault, TX3_Fault, and TX4_Fault do not need to be connected.

Digital Diagnostic Interface and Serial Identification (EEPROM)

The PCB mount transceiver is compatible with the SFF-8074i SFP specification and with SFF-8472, the SFP specification for Digital Diagnostic Monitoring Interface. Both specifications can be found at <http://www.sffcommittee.org>.

050-336 PRODUCT BRIEF
PCB Mount Quad Transmitter
100 Mbps – 5 Gbps, MMF, 3.3V



FIGURE 4 – DIGITAL DIAGNOSTIC MEMORY MAP OVERVIEW

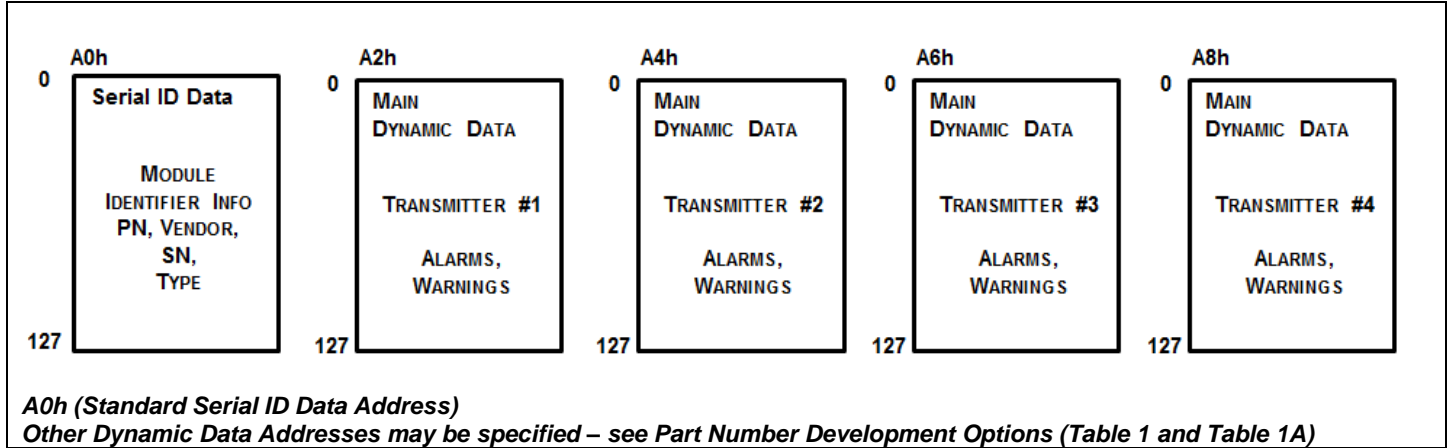

The PCB mount transmitter features EEPROM for Serial ID, which contains the product data stored for retrieval by host equipment. This data is accessed via the 2-wire serial EEPROM protocol in compliance with the industry standard SFP Multi-Source Agreement but modified to work with Quad-Transmitter. Figure 4 illustrated the Memory Map overview. The base EEPROM memory, bytes 0-255 at memory address A0h, is organized in compliance with SFF-8074i.

As an enhancement to the conventional SFP interface defined in SFF-8074i, and the unit is compliant to SFF-8472 (digital diagnostic interface for optical transmitter sections). This new digital diagnostic information is stored in bytes 0-127 at memory address A2h (TX1), A4h (TX2), A6h (TX3), A8h (TX4). Using the 2-wire serial interface defined in the MSA, the PCB mount Transmitter provides real time temperature, supply voltage, laser bias current and laser average output power for each of the four transmitters. These parameters are internally calibrated, per the SFF-8472 MSA. The digital diagnostic interface also adds the capability to monitor for Transmitter Faults (TX_FAULT). The diagnostic information provides the opportunity for Predictive Failure Identification, Compliance Prediction, Fault Isolation and Component Monitoring.

Predictive Failure Identification

The predictive failure feature allows a host to identify potential link problems before system performance is impacted. Prior identification of link problems enables a host to service an application via “fail over” to a redundant link or replace a suspect device, maintaining system uptime in the process. For applications where ultra-high system uptime is required, the PCB mount transmitter provides a means to monitor two real-time laser metrics associated with observing laser degradation and predicting failure: average laser bias current (Tx Bias) and average laser optical power (Tx Power).

050-336 PRODUCT BRIEF
PCB Mount Quad Transmitter
100 Mbps – 5 Gbps, MMF, 3.3V



Compliance Prediction

Compliance prediction is the ability to determine if an optical transmitter is operating within its operating and environmental requirements. The transmitter provides real-time access to its internal supply voltage and temperature, allowing a host to identify potential component compliance issues.

Fault Isolation

The fault isolation feature allows a host to quickly pinpoint the location of a link failure, minimizing downtime. For optical links, the ability to identify a fault at a local device, remote device or cable plant is crucial to speeding service of an installation. PCB mount transmitter real-time monitors of Tx Bias, Tx Power, and Vcc, Temperature can be used to assess local unit's current operating conditions.

Component Monitoring

Component evaluation is another use of the PCB mount transmitter's real-time monitors of Tx Bias, Tx Power and Vcc, Temperature. Potential uses are as debugging aids for system installation and design, and transmitter parametric evaluation for factory or field qualification. For example, temperature per module can be observed in high density applications to facilitate thermal evaluation of systems that incorporate this PCB mount transmitter.

Required Host Board Components

A power supply noise rejection filter as describe in SFP MSA is required on the host PCB to meet data sheet performance. This is the same filter incorporates an inductor which should be rated 400 mADC and 1 Ω series resistance or better. It should not be replaced with a ferrite. The required filter is illustrated in Figure 5. Also, the host PCB for the PCB mount transceiver requires 4.7 K to 10 K Ω pull-up resistors for TX_FAULT, SCA and SDL lines.

**FIGURE 5 – RECOMMENDED HOST BOARD POWER SUPPLY FILTERING CIRCUIT
SINGLE TRANSMITTER SHOWN (X4 TRANSMITTERS PER MODULE)**

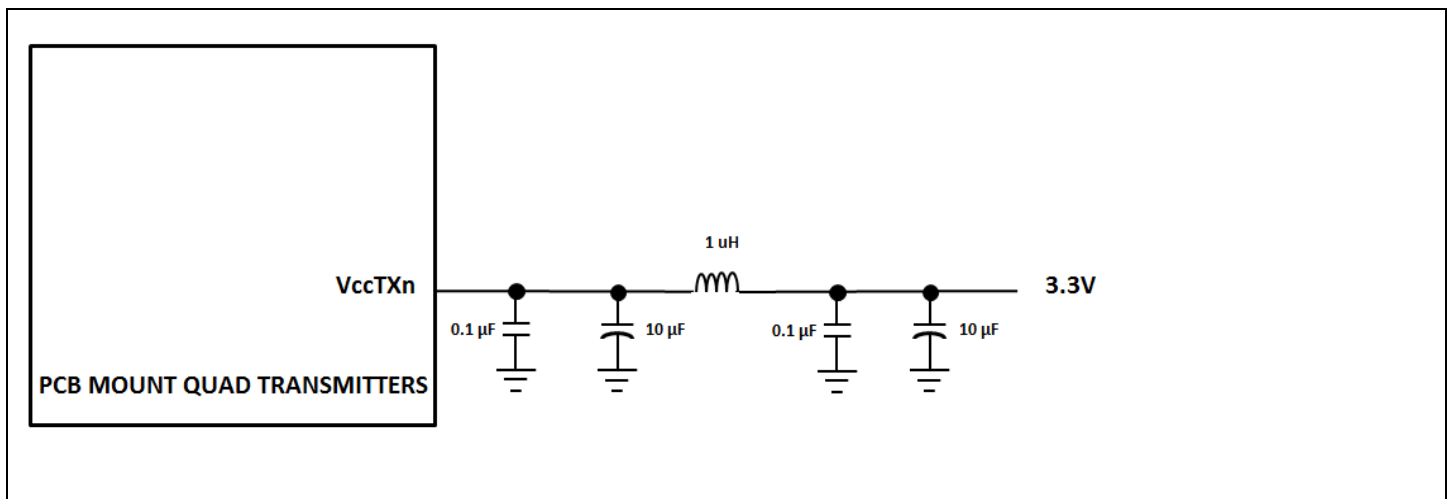

Fiber Compatibility

The transmitter is capable of transmission at 2 to 550 meters with 50/125 μ m fiber, and at 2 to 275 meters with 62.5/125 μ m fiber, for 1.25 GBd Ethernet. It is capable of transmission up to 550m with 50/125 μ m fiber and up to 300m with 62.5/125 μ m fiber, for 1.0625 GBd Fiber Channel.

Electrostatic Discharge (ESD)

The transmitter is compatible with ESD levels found in typical manufacturing and operating environments as described JDEC/EIAJESD22-A114-A, Class 1 (<2000Volts) HBM. Glenair recommends that devices are handled with ESD precautions to limit exposure to below 500V HBM.

There are two design cases in which immunity to ESD damage is important. The first case is during handling of the transmitter prior to insertion to the host board. To protect the unit, it's important to use standard industry ESD handling precautions. These precautions include using grounded wrist straps, work benches, and floor mats in ESD controlled areas. The ESD sensitivity of the Glenair PCB mount transceiver is compatible with typical industry production environments.

The second case to consider is static discharges to the exterior of the host equipment after installation, in which case the transmitter may be subject to system-level ESD requirements.

050-336 PRODUCT BRIEF
PCB Mount Quad Transmitter
100 Mbps – 5 Gbps, MMF, 3.3V



TABLE 8 TWO-WIRE INTERFACE ID: DATA FIELDS – ADDRESS A0h

Byte Decimal	# Hex	Data Notes	Byte Decimal	# Hex	Data Notes
0	80	Glenair PCB mount Transceiver	37	00	Vendor OUI (NOT USED)
1	04	Serial ID Module Definition	38	00	Vendor OUI (NOT USED)
2	80	ARINC 801 Fiber Optic Connector	39	00	Vendor OUI (NOT USED)
3	00		40	30	"0" Vendor Part Number ASCII character (Note 5)
4	00		41	35	"5" Vendor Part Number ASCII character (Note 5)
5	00		42	30	"0" Vendor Part Number ASCII character (Note 5)
6	01	1000BASE-SX	43	2D	"-" Vendor Part Number ASCII character (Note 5)
7	00		44	33	"3" Vendor Part Number ASCII character (Note 5)
8	00		45	33	"3" Vendor Part Number ASCII character (Note 5)
9	00		46	36	"6" Vendor Part Number ASCII character (Note 5)
10	00		47	43	"C" Vendor Part Number ASCII character (Note 5)
11	01	Compatible with 8B/10B encoded data	48	30	"0" Vendor Part Number ASCII character (Note 5)
12	32	BR, 5Gbps	49	2D	"-" Vendor Part Number ASCII Character (Note 5)
13	00		50	44	"4" Vendor Part Number ASCII Character (Note 5)
14	00		51	2D	"-" Vendor Part Number ASCII Character (Note 5)
15	00		52	44	"D" Vendor Part Number ASCII Character (Note 5)
16	37	550m of 50/125µm Fiber @ 1.25Gbps	53	20	" " Vendor Part Number ASCII Character (Note 5)
17	1B	275 m of 62.5/125µm Fiber @ 1.25Gbps	54	20	" " Vendor Part Number ASCII Character (Note 5)
18	00		55	20	" " Vendor Part Number ASCII Character (Note 5)
19	00		56	20	" " Vendor REV Level ASCII Character (Note 5)
20	47	"G" Vendor NAME ASCII Character	57	20	" " Vendor REV Level ASCII Character (Note 5)
21	4C	"L" Vendor NAME ASCII Character	58	20	" " Vendor REV Level ASCII Character (Note 5)
22	45	"E" Vendor NAME ASCII Character	59	20	" " Vendor REV Level ASCII Character (Note 5)
23	4E	"N" Vendor NAME ASCII Character	60	03	Hex Byte of Laser Wavelength (Note 6)
24	41	"A" Vendor NAME ASCII Character	61	52	Hex Byte of Laser Wavelength (Note 6)
25	49	"I" Vendor NAME ASCII Character	62		RESERVED
26	52	"R" Vendor NAME ASCII Character	63		Check sum code for ID fields 0-62 (Note 7)
27	20	" " Vendor NAME ASCII Character	64	00	
28	20	" " Vendor NAME ASCII Character	65	18	Hardware TX_Disable, TX_Fault
29	20	" " Vendor NAME ASCII Character	66	00	
30	20	" " Vendor NAME ASCII Character	67	00	
31	20	" " Vendor NAME ASCII Character	68-83		Serial Number, ASCII (Note 8)
32	20	" " Vendor NAME ASCII Character	84-91		Date Code (Note 9)
33	20	" " Vendor NAME ASCII Character	92	68	Diagnostic Monitoring Type
34	20	" " Vendor NAME ASCII Character	93	A0	Enhanced Options
35	20	" " Vendor NAME ASCII Character	94	05	SFF-8472 rev 11.0
36	00		95		Checksum for bytes 64-94 (Note 7)
			96-255	00	

Notes:

1. FC-PI speed 100 MBytes/sec is a serial bit rate of 1.0625 GBit/sec.
2. RESERVED
3. Link distance with 62.5/125µm cable at 1.25Gbps is 275m.
4. RESERVED.
5. Table 1, Part number options/extensions. Temperature and Screw Length Mod Codes will not be added onto Digital Memory ID.
6. Laser wavelength is represented in 16 unsigned bits. The hex representation of 850nm is 0352.
7. Addresses 63 and 95 are checksums calculated per SFF-8472 and SFF-8074, and stored prior to product shipment.
8. Addresses 68-83 specify the module's ASCII serial number and will vary by unit.
9. Addresses 84-91 specify the module's ASCII date code and will vary according to manufactured date-code.

050-336 PRODUCT BRIEF
PCB Mount Quad Transmitter
100 Mbps – 5 Gbps, MMF, 3.3V



Table 9 Two-Wire interface ID: Data Fields – Address A2h (TX1), A4h (TX2), A6h (TX3), A8h (TX4) Standard, See Table 1A for other addressing options

NOTE: RX Data fields are not applicable in this table (i.e. Addresses 32-39 and 104-105)

Byte # Decimal	Data Notes	Byte # Decimal	Data Notes	Byte # Decimal	Data Notes
0	Temp H Alarm MSB (Note 1)	26	TX Pwr L Alarm MSB (Note 4)	104	Reserved
1	Temp H Alarm LSB (Note 1)	27	TX Pwr L Alarm LSB (Note 4)	105	Reserved
2	Temp L Alarm MSB (Note 1)	28	TX Pwr H Warning MSB (Note 4)	106	Reserved
3	Temp L Alarm LSB (Note 1)	29	TX Pwr H Warning LSB (Note 4)	107	Reserved
4	Temp H Warning MSB (Note 1)	30	TX Pwr L Warning MSB (Note 4)	108	Reserved
5	Temp H Warning LSB (Note 1)	31	TX Pwr L Warning LSB (Note 4)	109	Reserved
6	Temp L Warning MSB (Note 1)	32	Reserved	110	Status/Control
7	Temp L Warning LSB (Note 1)	33	Reserved	111	Reserved
8	Vcc H Alarm MSB (Note 2)	34	Reserved	112	Flag Bits
9	Vcc H Alarm LSB (Note 2)	35	Reserved	113	Flag Bits
10	Vcc L Alarm MSB (Note 2)	36	Reserved	114	Reserved
11	Vcc L Alarm LSB (Note 2)	37	Reserved	115	Reserved
12	Vcc H Warning MSB (Note 2)	38	Reserved	116	Flag Bits
13	Vcc H Warning LSB (Note 2)	39	Reserved	117	Flag Bits
14	Vcc L Warning MSB (Note 2)	40-45	Reserved	118	Reserved
15	Vcc L Warning LSB (Note 2)	56-94	External Cal Constants (Note 4)	119	Reserved
16	Tx Bias H Alarm MSB (Note 3)	95	Checksum for bytes 0-94	120-122	Reserved
17	Tx Bias H Alarm LSB (Note 3)	96	Temperature MSB (Note 1)	123	Reserved
18	Tx Bias L Alarm MSB (Note 3)	97	Temperature LSB (Note 1)	124	Reserved
19	Tx Bias L Alarm LSB (Note 3)	98	Vcc MSB (Note 2)	125	Reserved
20	Tx Bias H Warning MSB (Note 3)	99	Vcc LSB (Note 2)	126	Reserved
21	Tx Bias H Warning LSB (Note 3)	100	TX Bias MSB (Note 3)	127	Reserved (Note 8)
22	Tx Bias L Warning MSB (Note 3)	101	TX Bias LSB (Note 3)	128-247	Customer Writable (Note 9)
23	Tx Bias L Warning LSB (Note 3)	102	TX Power MSB (Note 4)	248-255	Vendor Specific
24	TX Pwr H Alarm MSB (Note 4)	103	TX Power LSB (Note 4)		
25	TX Pwr H Alarm LSB (Note 4)				

Notes:

1. Temperature (Temp) is decoded as a 16 bit signed twos complement integer in increments of 1/256 °C.
2. Supply voltage (VCC) is decoded as a 16 bit unsigned integer in increments of 100 µV.
3. Laser bias current (Tx Bias) is decoded as a 16 bit unsigned integer in increments of 2 µA.
4. Transmitted average optical power (Tx Pwr) is decoded as a 16 bit unsigned integer in increments of 0.1 µW.
5. Received average optical power (Rx Pwr) is decoded as a 16 bit unsigned integer in increments of 0.1 µW.
6. Bytes 55-94 are not intended from use but have been set to default values per SFF-8472.
7. Bytes 95 is a checksum calculated (per SFF-8472) and stored prior to product shipment.
8. Byte 127 accepts a write but performs no action (reserved legacy byte).
9. Bytes 128-247 are write enabled (customer writable).

050-336 PRODUCT BRIEF
PCB Mount Quad Transmitter
100 Mbps – 5 Gbps, MMF, 3.3V



TABLE 10 TRANSCEIVER DIGITAL DIAGNOSTIC MONITOR CHARACTERISTICS (WHEN APPLICABLE)
NOTE: RECEIVER PARAMETERS ARE NOT APPLICABLE

PARAMETER	SYMBOL	MIN.	UNITS	NOTES
Transceiver Internal Temperature Accuracy	TINT	±3.0	°C	Temperature is measured internal to the transceiver and is valid from -40°C to +85 °C case temperature
Transceiver internal Supply Voltage accuracy	VINT	±0.1	V	Supply voltage is measured internal to the transceiver and can, with less accuracy, be correlated to the voltage at the Vcc pin. Valid over 3.3V ±5%
Transmitter Laser DC Bias Current Accuracy	IINT	±10	%	
Transmitted Average Optical Output Power Accuracy	PT	±3.0	dB	Coupled into 50/125 mm MM fiber. Valid from -1dBm to -10dBm
Received Average Optical Input Power Accuracy	PR	±3.0	dB	Coupled from 50/125 mm MM fiber. Valid from -24 dBm to - 1 dBm

ACCESSORIES

Fiber Optic Jumper Cables to support connection to Mil/Aerospace Connectors

KEY FEATURES:

- Jumper cable between ARINC 801 (end A) and Mil/Aero Connector termini (End B)
- Offered with Multimode fibers

FIGURE 6
Fiber Optic Jumper Cable Assembly (see separate Glenair sales drawing FA02454 for details)

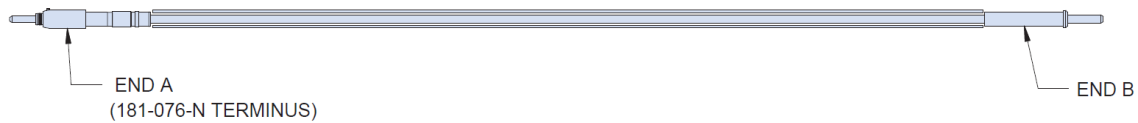

PCB Threaded Inserts, PN 059-0007

KEY FEATURES

- Simplifies installation of PCB Mount Modules eliminating the need for washers and nuts
- Soldered to PCB to eliminate need for handling nuts during assembly
- Existing Options to support PCB thickness from 0.03" to 0.92"
- Can support thicker PCB if required

EVALUATION Boards, PN 050-338 Include

- MANUAL with test block diagram, schematic
- Evaluation board PCBA
- 4 fiber optic cables (~1m MMF, ARINC 801 connector to LC connector)

