



050-357

PRODUCT BRIEF
SMPTE HD-SDI AND 3G-SDI
PRINTED CIRCUIT BOARD (PCB) MOUNT
DUAL PIN/TIA RECEIVER FOR SINGLE MODE FIBER (SMF)
SMALL & COMPACT WITH RUGGED CONSTRUCTION FOR
HARSH ENVIRONMENTS

REV	DESCRIPTION	DATE	APPROVED
1	Preliminary	06/08/2015	SZ
2	Add ECCN	05/26/2016	RAS
3	Change PRBS Specification to 2 ⁷ -1	10/12/2016	SZ/GC
4	Edit Bag and Tag Labeling	12/13/2016	RAS/GC
5	Remove incorrect reference to EEPROM protocol of the ATMEL AT240C01A, added optional I2C addressing	02/28/2017	RAS/GC
6	Change 3G-SDI max. receiver sensitivity to meet SMPTE 424 requirement	07/07/2017	SZ/GC

BF15U2-3099

THIS COPYRIGHTED DOCUMENT IS THE PROPERTY OF GLENAIR, INC. AND IS FURNISHED ON THE CONDITION THAT IT IS NOT TO BE DISCLOSED, REPRODUCED IN WHOLE OR IN PART, OR USED TO SOLICIT QUOTATIONS FROM COMPETITIVE SOURCES, OR USED FOR MANUFACTURE BY ANYONE OTHER THAN GLENAIR, INC. WITHOUT WRITTEN PERMISSION FROM GLENAIR, INC. THE INFORMATION HEREIN HAS BEEN DEVELOPED AT GLENAIR'S EXPENSE AND MAY BE USED FOR ENGINEERING EVALUATION AND INCORPORATION INTO TECHNICAL SPECIFICATIONS AND OTHER DOCUMENTS WHICH SPECIFY PROCUREMENT OF PRODUCTS FROM GLENAIR, INC.

050-357 PRODUCT BRIEF
PCB Mount Dual-Receiver
HD-SDI & 3G-SDI, SMF, 3.3V



PCB Mount Fiber Optic Dual-Receiver, 1.485Gbps - 2.970Gbps, SMF, 3.3V

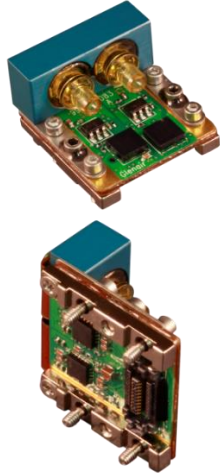

Glenair 050-357, is a ruggedized harsh environment PCB mount Dual-Receiver with electrical and optical functionality equivalent to SFP Dual-Receivers but with mechanical design that is suited to the harsh temperature and vibration environments found in Military, Aerospace, Railway, Oil and Gas, and Industrial applications. The PCB mount optical Dual-Receivers also support optional Digital Monitoring Interface (DMI) features in accordance with SFF 8472.

The receiver includes two (2) Receiver Optical Subassemblies (ROSA) and amplification/quantization circuitry. The ROSAs, containing a PIN photodiode and trans-impedance preamplifier, are located at the optical interface and mate with the GC optical connector. Each ROSA is followed by a limiting amplifier IC that provides post-amplification and quantization. Also included is a Loss Of Signal (LOS) detection circuit. These receiver designs are specifically targeted at to support SMPTE 424 (3G-SDI) and SMPTE 292 (HD-SDI), with special considerations to comply with the SMPTE Pathological test cases as described in SMPTE EG 34:2004. This transceivers support BER <10⁻¹² with Pathological test conditions CASE1, CASE2, and CASE3.

KEY FEATURES/BENEFITS

- SMPTE EG 34:2004 Compliant to Pathological Conditions CASE 1, CASE 2, and CASE 3.
- SMPTE ST 297:2006 (3G-SDI & HD-SDI)
- SMPTE 424 Compliant (3G-SDI)
- SMPTE 292 Compliant (HD-SDI)
- SFP Compatible Electrical I/O signal levels
- PIN PD to support high sensitivity up to 3 Gbps
- Glenair Rugged GC Optical connector for high shock and vibration applications
- Module is securely mounted with screws to PCB to ensure excellent shock and vibration performance
- High-Speed Electrical plug-in connector eliminates the need for soldering & enables ease of servicing
- Captive screws to simplify assembly operations
- Compact size: Approx 0.8" x 0.9" x 0.5"
- -40°C to +85°C Operating Case Temperature
- Glenair fiber jumpers connect from PCB Mount Module to any Glenair Mil/Aero Fiber Optic Connector Style
- Evaluation fixtures available
- Digital Diagnostic and Monitoring (DMI) based on SFF-8472, enables monitoring of:
 - RX optical power for each receiver, Temperature, Supply Voltage

APPLICATIONS

- Harsh Environment such as: Airborne, Tactical, Railway, Industrial, Oil and Gas and Shipboard applications
 - SMPTE 3G & HD-SDI Video Applications

HOW TO ORDER Table 1 Part Number Development Options

Part Number	Two Wire Address	Data Rate	Temperature**	Screw Length** (Mod Code)
050-357	Blank = A2h, A4h	-1-D = HD-SDI	Blank = Standard	Blank = Standard
PCB Mount Dual-Receiver, SMF, 850nm HD-SDI 3G-SDI	Other Options: See Table 1A	-2-D = 3G-SDI		-954-xxx = IAW Mod Code 954

Example: **050-357C2-1-D**

PCB Mount Dual-Receiver, SMF, 850nm, Two Wire Address = C2h & C4h, Data Rate = HD-SDI, Standard Temperature Range, Standard Screw Length

**Temperature and Screw Length Mod Codes will not be added onto Digital Memory ID (See Table 8)

050-357 PRODUCT BRIEF
 PCB Mount Dual-Receiver
 HD-SDI & 3G-SDI, SMF, 3.3V



TABLE 1A TWO WIRE ADDRESS –IDENTIFIER OPTIONS

PN Identifier	Transceiver #1 Address	Transceiver #2 Address
Blank	A2h	A4h
A6	A6h	A8h
B2	B2h	B4h
B6	B6h	B8h
C2	C2h	C4h
C6	C6h	C8h
D2	D2h	D4h
D6	D6h	D8h
E2	E2h	E4h
E6	E6h	E8h

**Contact Glenair if additional addresses required*

Ratings and Specifications

©2015 Glenair, Inc.

REV: 6

US Cage Code 06324

Printed in USA

GLENAIR, INC.

1211 AIR WAY

GLENDAL, CA 91201-2497

TEL: 818-247-6000

FAX: 818-500-9912

www.glenair.com

PAGE 3 of 16

E-mail: sales@glenair.com

050-357 PRODUCT BRIEF
PCB Mount Dual-Receiver
HD-SDI & 3G-SDI, SMF, 3.3V



TABLE 2 ABSOLUTE MAXIMUM RATINGS

Parameter	Symbol	Min	Typ	Max	Units	Notes
Storage Temperature	T _s	-55		+100	°C	
Supply Voltage	V _{cc}	-0.4		3.8	V	V _{ccR} may not differ by more than 0.5V

TABLE 3 OPERATING CONDITIONS

Parameter	Symbol	Min	Typ	Max	Units	Notes
Operating Temperature, Case	T _{op}	-40		+85	°C	
Supply Voltage	V _{cc}	3.135	3.3	3.465	V	
Supply Current	I _{cc}		180	250	mA	Typical @ +85°C
Power Supply Noise (Peak-Peak)	V _{cc, ripple}			100	mV	

TABLE 4 ELECTRO-OPTICAL CHARACTERISTICS - RECEIVER

Parameter	Symbol	Min	Typ	Max	Units	Notes
050-357-1-D						
Sensitivity, BER 10 ⁻¹² , PRBS 2 ⁷ -1, Er 10 dB	P _{IN}		-23	-20	dBm	PIN PD @ 1.485 Gbps
050-357-2-D						
Sensitivity, BER 10 ⁻¹² , PRBS 2 ⁷ -1, Er 10 dB	P _{IN}		-22	-17	dBm	PIN PD @ 2.970 Gbps
Overload, BER 10 ⁻¹² , PRBS 2 ⁷ -1	P _{IN}	-1			dBm	@ 1.485 Gbps or @ 2.970 Gbps
Optical Wavelength	λ _{IN}	1200		1600	nm	
Receiver Differential Output Impedance	Z _{out}		100		Ohms	AC coupled internally
Differential Output Voltage Swing	V _{out_d}	600		1200	mV	CML, 100 ohm
LOS Assert Level	LOS		-25	-22	dBm	@ 1.485 Gbps or @ 2.970 Gbps
LOS Hysteresis	LOS _{HYS}	1.25	2.3		dB	@ 1.485 Gbps or @ 2.970 Gbps

TABLE 5 COMPLIANCE SPECIFICATIONS

CHARACTERISTIC	Standard	Condition	Notes
Mechanical Shock	MIL-STD-810	Para. 516.6, proc. I, 650g	0.9 ms operating
Mechanical Vibration	MIL-STD-810	Para. 514.6, 40g rms	Random, operating
ESD	MIL-STD-883		1000V HBM
Flame Resistance	MIL-STD-1344	Method 1012, Cond. B	30 seconds
Damp Heat	MIL-STD-1344	Method 1002.2, Cond. B	10 cycles , 24 hours
Eye Safety	CDRH and IEC-825	Class 1 Laser Product	

050-357 PRODUCT BRIEF
PCB Mount Dual-Receiver
HD-SDI & 3G-SDI, SMF, 3.3V



Ratings and Specifications (continued)

TABLE 6 MATERIAL/FINISH

Item	Material/Finish
PCB	FR4
PCB flex	FR4 & Polyimide
Railings	Aluminum 6061-T6 per ASTM-B221/B211M or Equivalent
Screws	CRES Type, 302, 303, 304, 305, or 316
Optical Ferrules & Sleeves	Zirconia, Ceramic
Solder type	RoHS compliant Sn95/Sb5 (232°C melting temp) & RoHS compliant Sn96.5/Ag3.0/Cu0.5 (217° melting)

050-357 PRODUCT BRIEF
PCB Mount Dual-Receiver
HD-SDI & 3G-SDI, SMF, 3.3V



FIGURE 1 - OUTLINE DRAWING CONTINUED (MARKING)

LABELING:

Each unit will be shipped in an antistatic bag. The label on the antistatic bag shall be at a minimum Arial size 10 black font and contain at a minimum the following information:

ANTISTATIC BAG LABEL:

Glenair

Cage Code: 06324

PN: 050-357XX-X-X

Rev: X

QTY: X

J/N: X

D/C: X

S/N*: XXXXXX

*If QTY is more than 1, there is no S/N

Each unit will be marked, either with a label or laser engraving, as follows:

1. Marking font to be Arial, greater than .08 inches in height.
2. Minimum Marking on each part will include the following:
 - Glenair
 - Serial number
 - Glenair Part Number

Example Minimum Marking:

GLENAIR SN123456

050-357C2-2-D

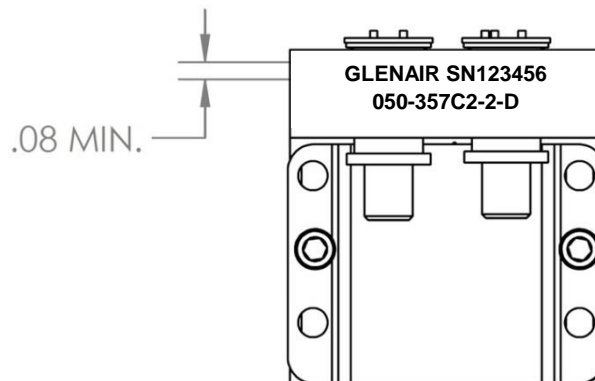

FUNCTIONAL DESCRIPTION

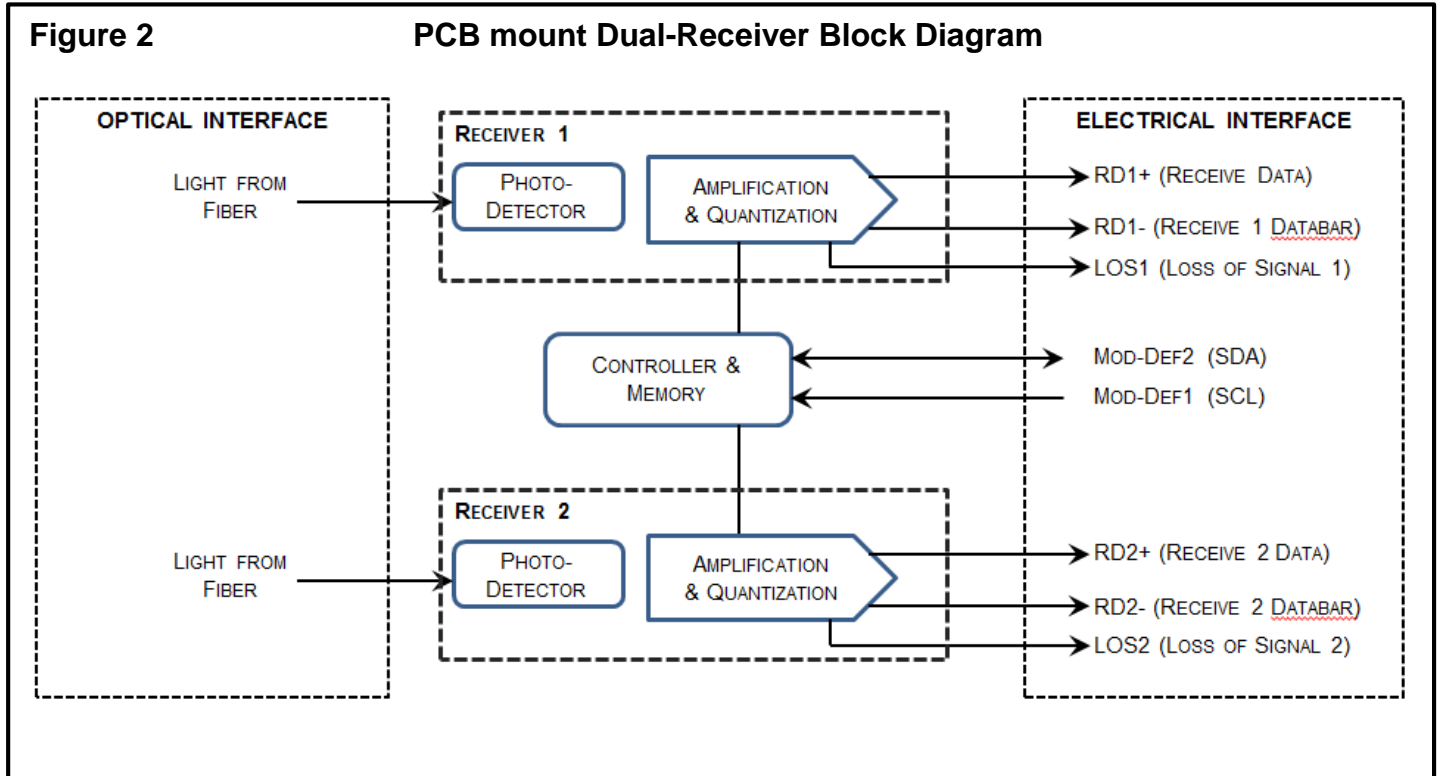

RECEIVER SECTION

Receiver Loss of Signal (LOS)

The Loss Of Signal (LOS) output indicates an unusable optical input power level. The post-amplification IC includes transition detection circuitry which monitors the ac level of incoming optical signals and provides a TTL/CMOS compatible status signal to the host. A low LOS logic level indicates the presence of an optical input while a high LOS logic level indicates an unusable optical input. The LOS thresholds are factory-set so that a high output indicates a definite optical fault has occurred (e.g. failed transmitter, broken or disconnected fiber connection to the PCB Mount Module, etc.). The LOS can also be monitored via the 2-wire serial interface (address A2h and A4h, byte 110, bit 1).

050-357 PRODUCT BRIEF
 PCB Mount Dual-Receiver
 HD-SDI & 3G-SDI, SMF, 3.3V



FUNCTIONAL I/O

The PCB mount Dual-Receiver accepts industry standard differential signals such as LVPECL and CML within the scope of the SFP MSA. The module is AC-coupled and internally terminated.

Figure 3 illustrates a recommended interface circuit to link the PCB mount Dual-Receiver to the supporting Physical Layer integrated circuits.

**FIGURE 3 RECOMMENDED PCB MOUNT DUAL-RECEIVER HOST BOARD SCHEMATIC
 SINGLE RECEIVER SHOWN (2X RECEIVERS PER MODULE)**

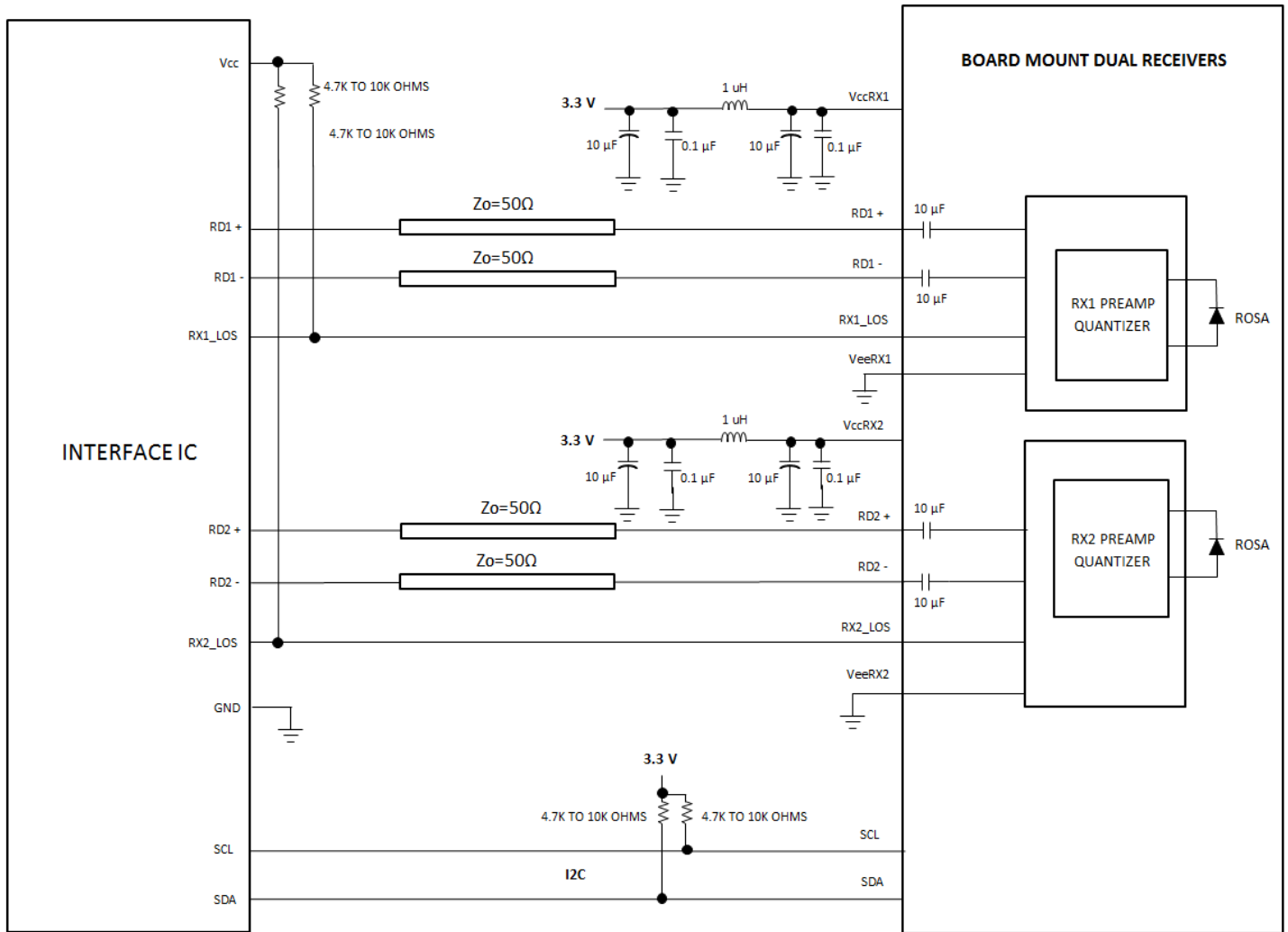

The PCB mount Dual-Receiver interfaces with the host circuit board through twenty I/O pins identified by function in Table 7. The Dual-Receiver high speed receive interface requires SFP MSA compliant signal lines on the host board. The Rx_LOS lines require TTL lines on the host board (per SFF-8074i) if used. If an application chooses not to take advantage RX_LOS do not need to be connected.

Digital Diagnostic Interface and Serial Identification (EEPROM)

The PCB mount Dual-Receiver is derived from the SFF-8074i SFP specification and with SFF-8472, the SFP specification for Digital Diagnostic Monitoring Interface, but modified to account for Dual-Receiver functionality. Both specifications can be found at <http://www.sffcommittee.org>.

FIGURE 4 – DIGITAL DIAGNOSTIC MEMORY MAP OVERVIEW

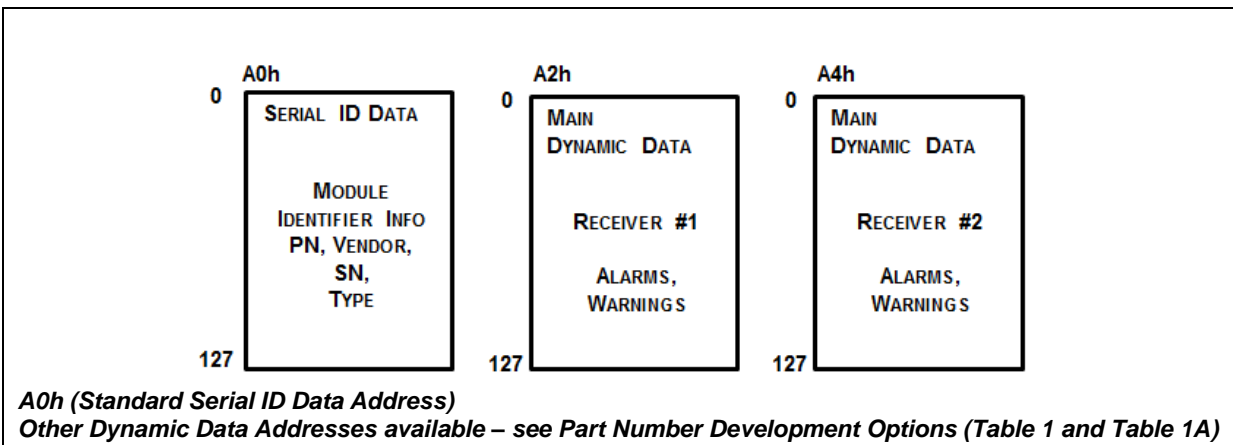

The PCB mount Dual-Receiver features EEPROM for Serial ID, which contains the product data stored for retrieval by host equipment. This data is accessed via the 2-wire serial EEPROM protocol derived from with the industry standard SFP Multi-Source Agreement but modified to account for Dual-Receiver functionality. The base EEPROM memory, bytes 0-255 at memory address A0h, is organized in compliance with SFF-8074i.

As an enhancement to the conventional SFP interface defined in SFF-8074i, the PCB mount Dual-Receiver is derived from SFF-8472 (digital diagnostic interface for optical transceivers) with memory organized as shown in Figure 4. This new digital diagnostic information is stored in bytes 0-255 at memory address A2h (RX1) and A4h (RX2). Using the 2-wire serial interface defined in the MSA, the PCB mount Dual-Receiver provides real time temperature, supply voltage, and received input power. These parameters are internally calibrated, per the SFF-8472 MSA. The digital diagnostic interface also adds the capability to monitor for Receiver Loss of Signal (RX_LOS). The diagnostic information provides the opportunity for Predictive Failure Identification, Compliance Prediction, Fault Isolation and Component Monitoring.



Compliance Prediction

Compliance prediction is the ability to determine if an optical Dual-Receiver is operating within its operating and environmental requirements. The PCB mount Dual-Receiver provides real-time access to its internal supply voltage and temperature, allowing a host to identify potential component compliance issues. Received optical power is also available to assess compliance of fiber cable plant and remote transmitter. When operating out of requirements, the link cannot guarantee error free transmission.

Fault Isolation

The fault isolation feature allows a host to quickly pinpoint the location of a link failure, minimizing downtime. For optical links, the ability to identify a fault at a local device, remote device or cable plant is crucial to speeding service of an installation. PCB mount Dual-Receiver real-time monitors of Vcc, Temperature and Rx_Power can be used to assess local Dual-Receiver current operating conditions. In addition, status flag Rx Loss of Signal (LOS) is mirrored in memory and available via the two-wire serial interface.

Component Monitoring

Component evaluation is another use of the PCB mount Dual-Receiver real-time monitors of Vcc, Temperature and Rx_Power. Potential uses are as debugging aids for system installation and design, and Dual-Receiver parametric evaluation for factory or field qualification. For example, temperature per module can be observed in high density applications to facilitate thermal evaluation of systems that incorporate this PCB mount Dual-Receiver

Required Host Board Components

A power supply noise rejection filter as describe in SFP MSA is required on the host PCB to meet data sheet performance. This is filter incorporates an inductor which should be rated to 400 mADC and 1 Ω series resistance or better. It should not be replaced with a ferrite. The required filter is illustrated in Figure 5. Also, the host PCB for the PCB mount Dual-Receiver requires 4.7 K to 10 K Ω pull-up resistors for TX_FAULT, LOS, SCA and SDL lines.

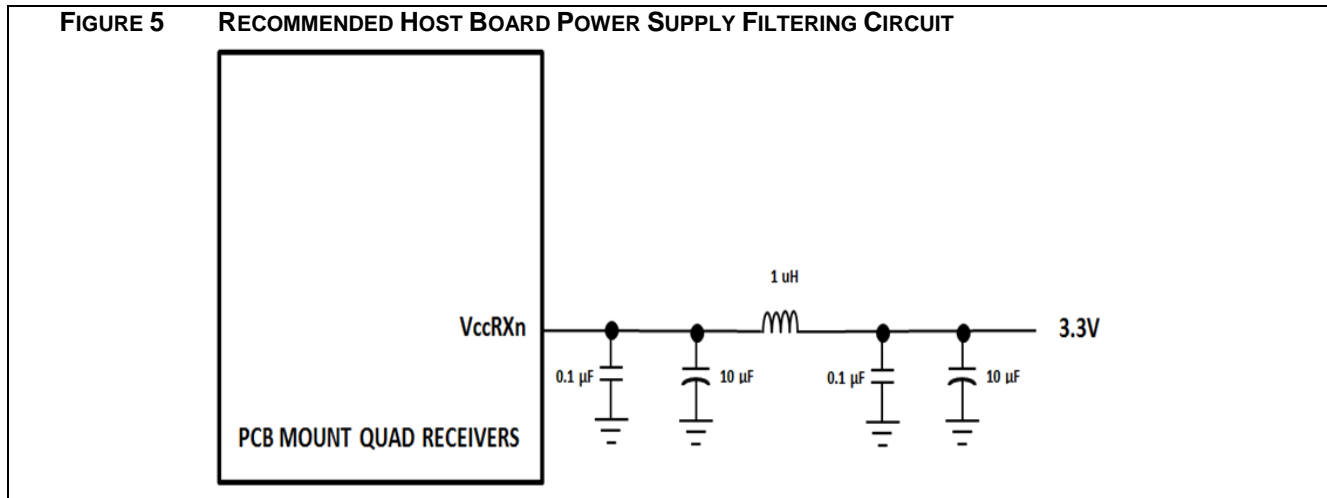

Fiber Compatibility

The transceiver is capable of transmission up to 10km with 9/125 μm fiber at 1.25Gbps data rate.

Electrostatic Discharge (ESD)

The Dual-Receiver is compatible with ESD levels found in typical manufacturing and operating environments as described JEDEC EIA JESD22-A114-A, Class 1 (<2000Volts) HBM. Glenair recommends that devices are handled with ESD precautions to limit exposure to below 500V HBM.

There are two design cases in which immunity to ESD damage is important. The first case is during handling of the Dual-Receiver prior to insertion to the host board. To protect the Dual-Receiver, it's important to use standard industry ESD handling precautions. These precautions include using grounded wrist straps, work benches, and floor mats in ESD controlled areas. The ESD sensitivity of the Glenair PCB mount Dual-Receiver is compatible with typical industry production environments.

The second case to consider is static discharges to the exterior of the host equipment after installation, in which case the Dual-Receiver may be subject to system-level ESD requirements.

**050-357 PRODUCT BRIEF
PCB Mount Dual-Receiver
HD-SDI & 3G-SDI, SMF, 3.3V**



Application Support

To assist in the Dual-Receiver design and evaluation process, Glenair offers the following aids:

- Evaluation board & Product Manual, part number 050-330, which facilitates in the testing of the PCB mount Dual-Receiver.
- 3D Step file to support modeling of mechanical fit and routing
- PADS schematic and PCB layout library files that can be exported into customer's PCB software design program
- Applications Aid Example of PCB layout including details of high speed transmission designs

Customer Manufacturing Processes

This module is mounted with screws and interfaces with a high-speed low cost surface mount electrical connector residing on the host PC board. The PCB mount Dual-Receiver is not designed for aqueous wash, IR reflow, or wave soldering processes and should be mounted on the host board after host PC board has been through its assembly process.

050-357 PRODUCT BRIEF
PCB Mount Dual-Receiver
HD-SDI & 3G-SDI, SMF, 3.3V



TABLE 8 TWO-WIRE INTERFACE ID: DATA FIELDS – ADDRESS A0h

Byte Decimal	# Hex	Data Notes	Byte Decimal	# Hex	Data Notes
0	80	Glenair PCB mount Dual-Receiver	37	00	Vendor OUI (NOT USED)
1	04	Serial ID Module Definition	38	00	Vendor OUI (NOT USED)
2	80	"GC" Fiber Optic Connector	39	00	Vendor OUI (NOT USED)
3	00		40	30	"0" Vendor Part Number ASCII Character (Note 5)
4	00		41	35	"5" Vendor Part Number ASCII Character (Note 5)
5	00		42	30	"0" Vendor Part Number ASCII Character (Note 5)
6	00		43	2D	"-" Vendor Part Number ASCII Character (Note 5)
7	00		44	33	"3" Vendor Part Number ASCII Character (Note 5)
8	00		45	35	"5" Vendor Part Number ASCII Character (Note 5)
9	00		46	37	"7" Vendor Part Number ASCII Character (Note 5)
10	00		47	43	"C" Vendor Part Number ASCII Character (Note 5)
11	03	NRZ	48	32	"2" Vendor Part Number ASCII Character (Note 5)
12	1E	BR, 3Gbps	49	2D	"-" Vendor Part Number ASCII Character (Note 5)
13	00		50	31	"1" Vendor Part Number ASCII Character (Note 5)
14	00		51	2D	"-" Vendor Part Number ASCII Character (Note 5)
15	64	10km of 9//125µm Fiber @ 2.97 Gbps	52	44	"D" Vendor Part Number ASCII Character (Note 5)
16	00		53	20	" " Vendor Part Number ASCII Character (Note 5)
17	00		54	20	" " Vendor Part Number ASCII Character (Note 5)
18	00		55	20	" " Vendor Part Number ASCII Character (Note 5)
19	00		56	20	" " Vendor REV Level ASCII Character (Note 5)
20	47	"G" Vendor NAME ASCII Character	57	20	" " Vendor REV Level ASCII Character (Note 5)
21	4C	"L" Vendor NAME ASCII Character	58	20	" " Vendor REV Level ASCII Character (Note 5)
22	45	"E" Vendor NAME ASCII Character	59	20	" " Vendor REV Level ASCII Character (Note 5)
23	4E	"N" Vendor NAME ASCII Character	60	05	Hex Byte of Laser Wavelength (Note 6)
24	41	"A" Vendor NAME ASCII Character	61	1E	Hex Byte of Laser Wavelength (Note 6)
25	49	"I" Vendor NAME ASCII Character	62		RESERVED
26	52	"R" Vendor NAME ASCII Character	63		Check sum code for ID fields 0-62 (Note 7)
27	20	" " Vendor NAME ASCII Character	64	00	
28	20	" " Vendor NAME ASCII Character	65	02	RX_LOS
29	20	" " Vendor NAME ASCII Character	66	00	
30	20	" " Vendor NAME ASCII Character	67	00	
31	20	" " Vendor NAME ASCII Character	68-83		Serial Number, ASCII (Note 8)
32	20	" " Vendor NAME ASCII Character	84-91		Date Code (Note 9)
33	20	" " Vendor NAME ASCII Character	92	68	Diagnostic Monitoring Type
34	20	" " Vendor NAME ASCII Character	93	90	Enhanced Options
35	20	" " Vendor NAME ASCII Character	94	05	SFF-8472 rev 11.0
36	00		95		Checksum for bytes 64-94 (Note 7)
			96-255	00	

Notes:

1. RESERVED
2. OM3 (2000 MHz-km)
3. OM1 (275 MHz-km)
4. RESERVED..
5. Table 1, Part number options/extensions. Temperature and Screw Length Mod Codes will not be added onto Digital Memory ID.
6. Laser wavelength is represented in 16 unsigned bits. The hex representation of 1310nm is 051E.
7. Addresses 63 and 95 are checksums calculated per SFF-8472 and SFF-8074, and stored prior to product shipment.
8. Addresses 68-83 specify the module's ASCII serial number and will vary by unit.
9. Addresses 84-91 specify the module's ASCII date code and will vary according to manufactured date-code.

050-357 PRODUCT BRIEF
PCB Mount Dual-Receiver
HD-SDI & 3G-SDI, SMF, 3.3V



Table 9 Two-Wire interface ID: Data Fields – Address A2h (RX1), A4h (RX2) standard (or see Table 1A for other options)
NOTE: TX Data fields are not applicable (i.e. address 16-31 and 100-103 are not applicable)

Byte # Decimal	Data Notes	Byte # Decimal	Data Notes	Byte # Decimal	Data Notes
0	Temp H Alarm MSB (Note 1)	26	Reserved	104	Rx Pavg MSB (Note 5)
1	Temp H Alarm LSB (Note 1)	27	Reserved	105	Rx Pavg LSB (Note 5)
2	Temp L Alarm MSB (Note 1)	28	Reserved	106	Reserved
3	Temp L Alarm LSB (Note 1)	29	Reserved	107	Reserved
4	Temp H Warning MSB (Note 1)	30	Reserved	108	Reserved
5	Temp H Warning LSB (Note 1)	31	Reserved	109	Reserved
6	Temp L Warning MSB (Note 1)	32	RX Pwr H Alarm MSB (Note 5)	110	Status/Control
7	Temp L Warning LSB (Note 1)	33	RX Pwr H Alarm LSB (Note 5)	111	Reserved
8	Vcc H Alarm MSB (Note 2)	34	RX Pwr L Alarm MSB (Note 5)	112	Flag Bits
9	Vcc H Alarm LSB (Note 2)	35	RX Pwr L Alarm LSB (Note 5)	113	Flag Bits
10	Vcc L Alarm MSB (Note 2)	36	RX Pwr H Warning MSB (Note 5)	114	Reserved
11	Vcc L Alarm LSB (Note 2)	37	RX Pwr H Warning LSB (Note 5)	115	Reserved
12	Vcc H Warning MSB (Note 2)	38	RX Pwr L Warning MSB (Note 5)	116	Flag Bits
13	Vcc H Warning LSB (Note 2)	39	RX Pwr L Warning LSB (Note 5)	117	Flag Bits
14	Vcc L Warning MSB (Note 2)	40-45	Reserved	118	Reserved
15	Vcc L Warning LSB (Note 2)	56-94	External Cal Constants (Note 4)	119	Reserved
16	Reserved	95	Checksum for bytes 0-94	120-122	Reserved
17	Reserved	96	Temperature MSB (Note 1)	123	Reserved
18	Reserved	97	Temperature LSB (Note 1)	124	Reserved
19	Reserved	98	Vcc MSB (Note 2)	125	Reserved
20	Reserved	99	Vcc LSB (Note 2)	126	Reserved
21	Reserved	100	Reserved	127	Reserved (Note 8)
22	Reserved	101	Reserved	128-247	Customer Writable (Note 9)
23	Reserved	102	Reserved	248-255	Vendor Specific
24	Reserved	103	Reserved		
25	Reserved				

Notes:

1. Temperature (Temp) is decoded as a 16 bit signed twos complement integer in increments of 1/256 °C.
2. Supply voltage (VCC) is decoded as a 16 bit unsigned integer in increments of 100 µV.
3. Laser bias current (Tx Bias) is decoded as a 16 bit unsigned integer in increments of 2 µA.
4. Transmitted average optical power (Tx Pwr) is decoded as a 16 bit unsigned integer in increments of 0.1 µW.
5. Received average optical power (Rx Pwr) is decoded as a 16 bit unsigned integer in increments of 0.1 µW.
6. Bytes 55-94 are not intended from use but have been set to default values per SFF-8472.
7. Bytes 95 is a checksum calculated (per SFF-8472) and stored prior to product shipment.
8. Byte 127 accepts a write but performs no action (reserved legacy byte).
9. Bytes 128-247 are write enabled (customer writable).

**050-357 PRODUCT BRIEF
PCB Mount Dual-Receiver
HD-SDI & 3G-SDI, SMF, 3.3V**



TABLE 10 DUAL-RECEIVER DIGITAL DIAGNOSTIC MONITOR CHARACTERISTICS (WHEN APPLICABLE)
NOTE: TRANSMITTER PARAMETERS NOT APPLICABLE

PARAMETER	SYMBOL	MIN.	UNITS	NOTES
Dual-Receiver Internal Temperature Accuracy	TINT	±3.0	°C	Temperature is measured internal to the Dual-Receiver and is valid from -40°C to +85 °C case temperature
Dual-Receiver internal Supply Voltage accuracy	VINT	±0.1	V	Supply voltage is measured internal to the Dual-Receiver and can, with less accuracy, be correlated to the voltage at the Vcc pin. Valid over 3.3V ±5%
Received Average Optical Input Power Accuracy	PR	±3.0	dB	Coupled from 50/125 mm MM fiber Valid from -24 dBm to - 1 dBm

ACCESSORIES

Fiber Optic Jumper Cables to support connection to Mil/Aerospace Connectors

KEY FEATURES:

- Jumper cable between Glenair PCB Mount Module (end A) and Mil/Aero Connector termini (End B)
- Offered with either Multimode and Single Mode fibers

FIGURE 6
Fiber Optic Jumper Cable Assembly (see separate Glenair sales drawing FA02454 for details)

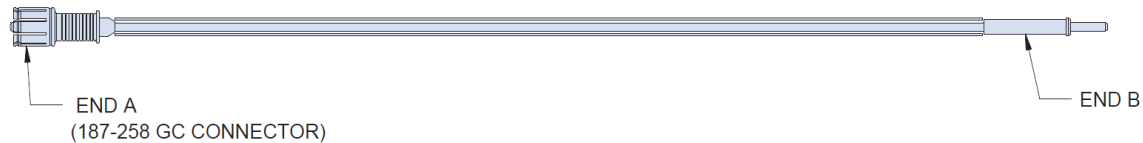

PCB Threaded Inserts, PN 059-0007

KEY FEATURES

- Simplifies installation of PCB mount PCB Mount Modules eliminating the need for washers and nuts
- Soldered to PCB to eliminate need for handling nuts during assembly
- Existing Options to support PCB thickness from 0.03" to 0.92"
- Can support thicker PCB if required

EVALUATION Boards, PN 050-330, include

- MANUAL with test block diagram, schematic and
- Evaluation board PCBA
- Multiple types of PCB mount modules supported by this evaluation board
- 2 fiber optic cables (~1m, 9 µm/125 µm, GC connector to LC connector)

