

059-0007
Kit, 100 pcs. Threaded PCB-Mount Fasteners
for PCB-Mount Transceivers

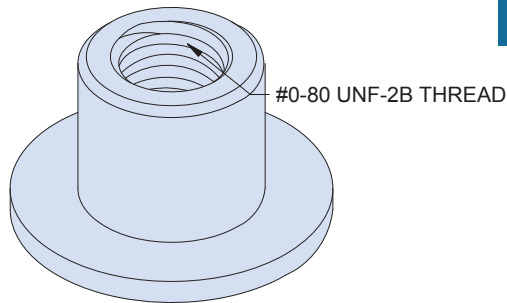

PCB Mount Fasteners

How To Order

Product Series

Kit of Threaded PCB Inserts (100 pcs.)

059 - 0007 - 1

059-0007-1 sold as a bag of 100 pcs.
 (Individual piece P/N 990-05017-1.
 Not sold separately)

KEY FEATURES

- Simplifies installation of PCB Mount Transceivers eliminating the need for separate washers and nuts
- Supports all PC boards above 0.062" nominal thickness

RECOMMENDED INSERT PADSTACK

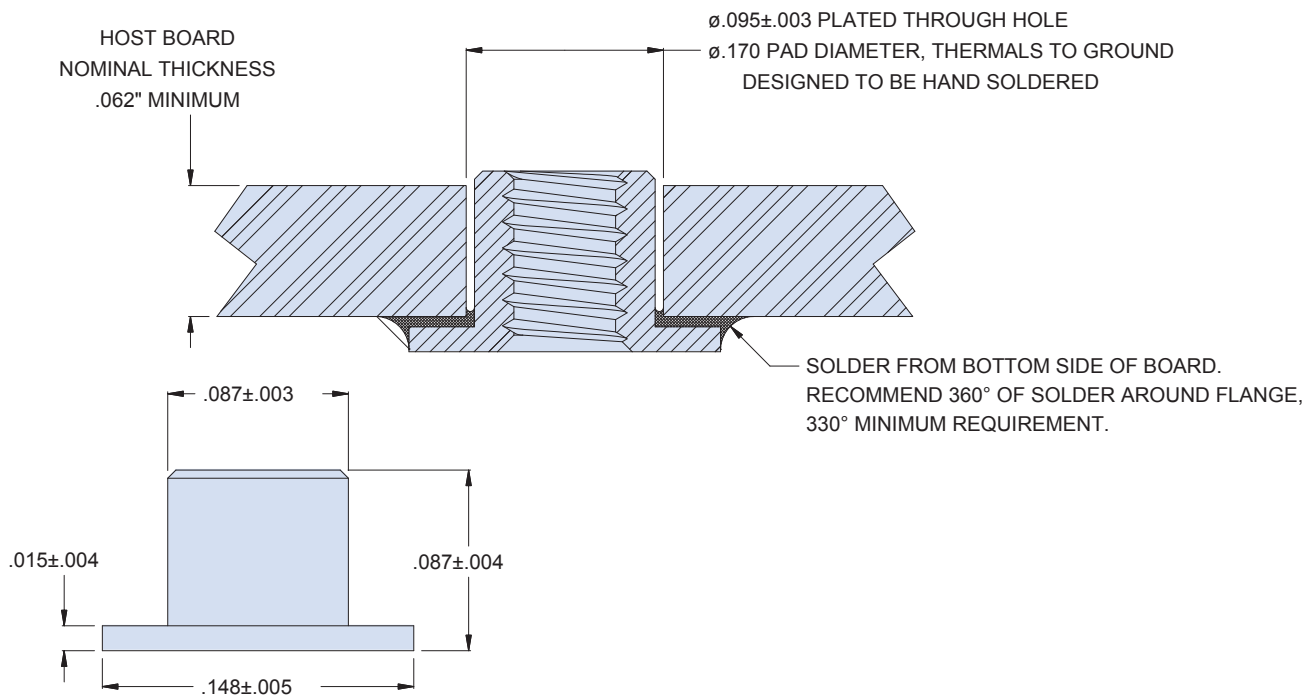

Material and Finish

Brass, Tin finish

Notes

Product sold in packs of 100.
 Recommended torque value of .5 to 1 in-lbs