



972-012 Wall-mount receptacle with banding platform, bus bar and lug contacts, bonded grommet for TurboFlex or tape-wrapped wire

POWERLOAD CONNECTORS - BUS BAR / LUG CONTACTS



972-012 Receptacle

HOW TO ORDER						
Sample Part Number	972-012	NF	32-3	P	1	A
Basic Part Number	PowerLoad™ Wall-Mount Receptacle with Banding Platform, Bonded Grommet for TurboFlex or Tape-Wrapped wire					
Material/Finish	ME, MT, NF, ZR, Z1, ZL (see Table)					
Shell Size / Contact Arrangement	See PowerLoad contact arrangements table					
Contact Gender	A = Pin, less contacts B = Socket, less contacts (see table for available contacts)					
Polarization	1, 2, 3, 4, 5, or 6					
Wire Diameter	A = standard wire, See Table III. Use code B for small-diameter wires, consult factory. Use Code Z for connector less wire sealing grommet.					

CONNECTOR FEATURES

- Socket towers for improved creep path performance
- Single-piece insulator eliminates bond lines that can lead to electrical failure
- High-vibration self-locking coupler
- High-temperature bus bar and lug type Crown Ring contacts

POWER SPECIFICATIONS

- For applications up to 2000 VAC/ 1500 Hz, and from 150 – 800 Amps.
- 230°C maximum operating temperature (stainless steel bodies and shells)
- 100% DWV tested at 5,000 VAC (all arrangements)
- Up to 60% lower contact resistance than equivalent AS39029 contacts (normalized, less wire)

MATERIAL SPECIFICATIONS

Insulators - PEEK thermoplastic, glass reinforced
 Seals - high-temperature silicone
 Contact body - high-conductivity copper alloy, gold plated
 Socket contact hood, crown ring - stainless steel, passivated

SHELL SIZE / CONTACT ARRANGEMENTS (FACE OF PIN INSERT)					
16-A1 1X #8	16-1 1X #4	20-A1 1X #2	20-1 1X #1/0	22-1* 1X #2/0	22-2 2X #8
22-3 3X #8	24-1* 1X #4/0	24-2 2X #4	24-4 4X #8	28-2 2X #2	28-3 3X #2
28-4 4X #4	28-6 6X #8	32-2 2X #1/0	32-3 3X #1/0	32-4 4X #2	
36-2* 2X #2/0	36-4 4X #1/0	40-3* 3X #2/0	#8 #4 #2 #1/0 #2/0 #4/0 Contact Size Key * Consult Factory		

Wire Gauge (AWG)	TURBOFLEX WIRE DIAMETER CODE AND WIRE PART NUMBER (BONDED GROMMET)										
	Single-Wall Hookup Wire					Dual-Wall Interconnect Cable					
	961-102-2000	961-106-1500	961-106-2000	961-108-1500	961-108-2000	961-103-2000	961-104-2000	961-107-1500	961-107-2000	961-109-1500	961-109-2000
8	A	A	A	A	A	+	+	A	+	A	+
4	A	A	A	A	A	+	+	A	+	A	+
2	A	A	A	A	A	A	A	A	+	A	A
0	A	A	A	A	A	A	A	A	+	A	A
00	A	∅	A	∅	A	A	A	A	A	A	A
0000	A	∅	A	∅	A	A	A	A	+	A	+

+: requires special termination, consult factory for how to order and terminate

972-012 Wall-mount receptacle with banding platform, bus bar and lug contacts, bonded grommet for TurboFlex or tape-wrapped wire

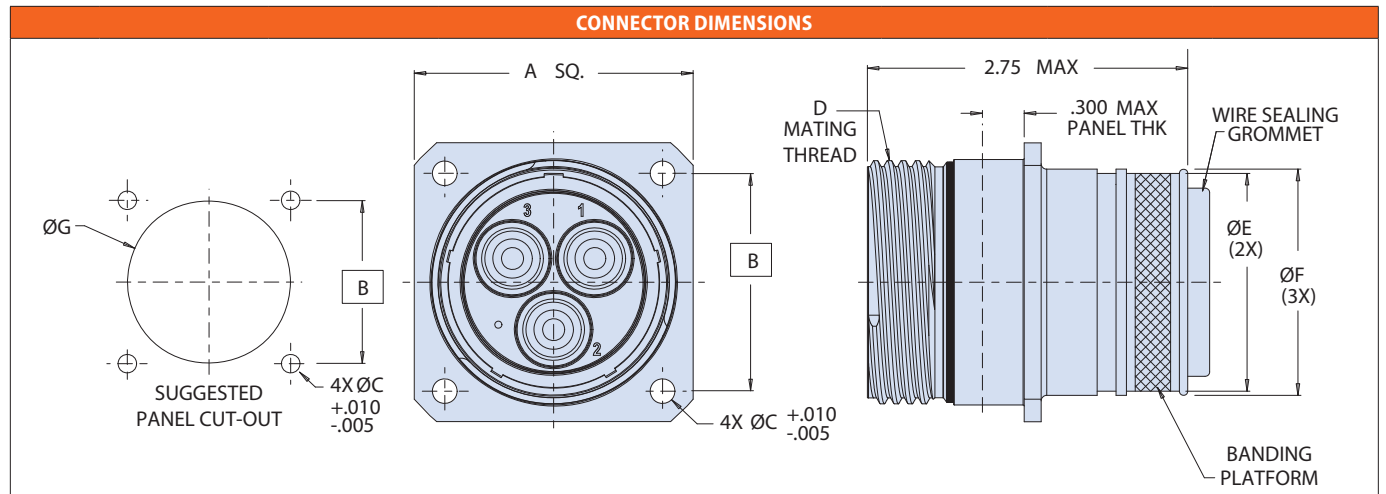

Shell Size	A ±.031	B Bsc	ØC Typ	D Mating Thread	ØE ±.015	ØF ±.015	ØG ±.010
16	1.281 (32.54)	.969 (24.61)	.150 (3.81)	1.000-0.1P-0.3L-TS-2A	.812 (20.62)	.875 (22.23)	1.062 (26.97)
20	1.500 (38.10)	1.156 (29.36)	.177 (4.5)	1.250-0.1P-0.3L-TS-2A	1.062 (26.97)	1.125 (28.58)	1.312 (33.32)
22	1.625 (41.28)	1.250 (31.75)	.177 (4.5)	1.375-0.1P-0.3L-TS-2A	1.187 (30.15)	1.250 (31.75)	1.437 (36.50)
24	1.750 (44.45)	1.375 (34.92)	.177 (4.5)	1.500-0.1P-0.3L-TS-2A	1.312 (33.32)	1.375 (34.92)	1.562 (39.67)
28	2.000 (50.80)	1.562 (39.67)	.177 (4.5)	1.750-0.1P-0.3L-TS-2A	1.562 (39.67)	1.625 (41.28)	1.812 (46.02)
32	2.250 (57.15)	1.750 (44.45)	.209 (5.3)	2.000-0.1P-0.3L-TS-2A	1.812 (46.02)	1.875 (47.63)	2.062 (52.37)
36	2.500 (63.50)	1.938 (49.23)	.209 (5.3)	2.250-0.1P-0.3L-TS-2A	2.062 (52.37)	2.125 (53.97)	2.312 (58.72)
40	2.750 (69.85)	2.188 (55.58)	.209 (5.31)	2.500-0.1P-0.3L-TS-2A	2.187 (55.55)	2.250 (57.15)	2.562 (65.07)

MATERIAL / FINISH			
Code	Material	Finish	Temp. Rating
ME	Aluminum	Electroless Nickel	-54°-+200°C
MT		Nickel-PTFE	-54°-+200°C
NF		Cadmium, OD	-54°-+175°C
ZR		Zinc-Ni, Black (Tri-Valent CR)	-54°-+175°C
Z1	Stainless Steel	Passivate	-54°-+230°C
ZL		Electrodeposited Nickel	-54°-+230°C

EXAMPLE CONTACT ARRANGEMENT CURRENT RATINGS				
Ins. Arr.	#8AWG 145 A ¹	#4 AWG 270 A ¹	#2 AWG 360 A ¹	1/0 490 A ¹
28-3			3X (156 A ²)	
28-4		4X (104 A ²)		
28-6	6X (49 A ²)			
32-3				3X (210 A ²)

¹ Absolute maximum current rating per SAE AS50881: single conductor, sea level, 205° temp rise (25° ambient to 230° C max for "Z1" connectors)
² Derated current for typical applications per SAE AS50881: multiple conductors, 50,000 ft. altitude, 100°C temp rise

AVAILABLE PIN CONTACTS			AVAILABLE SOCKET CONTACTS		
Part Number	Contact Size	Termination Style	Part Number	Contact Size	Termination Style
850-323-0-A	0	Internal Thread Style A	850-324-0-A	0	Internal Thread Style A
850-323-2-A	2		850-324-2-A	2	
850-323-4-A	4		850-324-4-A	4	
850-323-8-A	8		850-324-8-A	8	
850-323-0-C	0	Lug Style C	850-324-0-C	0	Lug Style C
850-323-2-C	2		850-324-2-C	2	
850-323-4-C	4		850-324-4-C	4	
850-323-8-C	8		850-324-8-C	8	

POWERLOAD CONNECTORS - BUS BAR / LUG CONTACTS