

Series 806 Mil-Aero PowerPlay

627V234 Composite Swing-Arm® Flex Strain Relief with EMI Adapter

SERIES 806 MIL-AERO POWERPLAY HIGH DENSITY



Drop-In EMI Adapter

Terminate cable braid shield to adapter with Band-Master ATS® strap. Slots in adapter are used for individual shield pigtails.



Straight, 45° or 90°

Loosen screws and re-position flex arms for optimum wire routing.

CONSTRUCTION

- Body, Coupling Nut, Flex Arms: high grade engineering thermoplastic, black
- Hardware: stainless steel, passivated
- Anti-Rotation Device: high grade engineering thermoplastic

HOW TO ORDER			
Shell Size	Shield Termination Adapter Finish		
	Electroless Nickel Code BM	Nickel-PTFE Code BMT	Olive Drab Cadmium Code BN
11	627V234BM11	627V234BMT11	627V234BN11
14	627V234BM14	627V234BMT14	627V234BN14
16	627V234BM16	627V234BMT16	627V234BN16
18	627V234BM18	627V234BMT18	627V234BN18
20	627V234BM20	627V234BMT20	627V234BN20

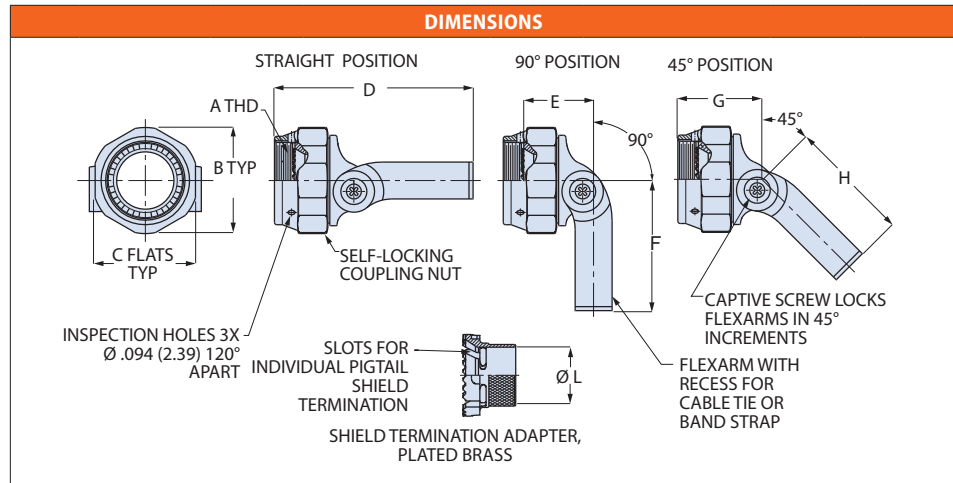

Shell Size	A ISO Metric Thd	øB Max.	C Max.	D Max.	E Max.	F Max.	G Max.	H Max.	ø L
11	M15 x 1.0-6H	.938 (23.83)	.875 (22.23)	1.77 (44.96)	.73 (18.54)	1.12 (28.45)	.70 (17.78)	1.11 (28.19)	.305 (7.75)
14	M19 x 1.0-6H	1.125 (28.58)	1.000 (25.40)	2.05 (52.07)	.84 (21.34)	1.41 (35.81)	.81 (20.57)	1.34 (34.04)	.472 (11.99)
16	M22 x 1.0-6H	1.250 (31.75)	1.125 (28.58)	2.05 (52.07)	.84 (21.34)	1.47 (37.34)	.75 (19.05)	1.42 (36.07)	.565 (14.35)
18	M25 x 1.0-6H	1.375 (34.92)	1.250 (31.75)	2.26 (57.40)	.94 (23.88)	1.65 (41.91)	.88 (22.35)	1.54 (39.12)	.658 (16.71)
20	M28 x 1.0-6H	1.500 (38.10)	1.375 (34.92)	2.26 (57.40)	.94 (23.88)	1.71 (43.43)	.81 (20.57)	1.63 (41.40)	.777 (19.74)