

973-003 SuperNine Series III PowerPlay with Threaded Contacts
00, D0, CS Panel-Mount Receptacles

SUPERNINE SERIES III POWERPLAY TRIPLE-START

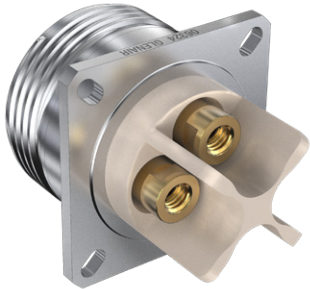

MATERIAL/FINISH

- Housing and coupling ring per How to Order Table
- Seal/grommet: silicone blend
- Contacts: copper alloy / gold
- Insulator: High-Temp composite

NOTES

- 973-003 mates with only 973-001 of the same size, layout, and polarization and the opposite gender.
- Electrical Performance:
 - DWV: 5000 VAC pin-pin and pin-shell (sea level)
 - Insulation resistance: 5000 megohm min at 500 VDC
- Customer shall analyze bus-bar design and attachment hardware, to ensure proper clearances are maintained for the intended application (max voltage, environmental conditions, etc.)

FINGER-PROOF CONTACTS		
Size	Pin	Socket
8	Yes	Yes
4	Yes	Yes
2	Yes	Yes
1/0	Yes	No
2/0	No	Yes

Finger-proof to IEC 60529 Level IP2X
(Rated voltages Not exceeding 1,000 VAC or 1500 VDC)

HOW TO ORDER						
Sample Part Number	973-003	-00	ME	17-2	P	N
Basic Part Number	SuperNine PowerPlay Connector					
Connector Style	00 = Receptacle, Panel-Mount with Slotted Holes D0 = Receptacle, Panel-Mount with Round Holes CS = Receptacle, Panel-Mount with Standard Clinch Nuts					
Connector Finish	NF = Aluminum, CAD/O.D. Over Electroless Nickel MT = Aluminum, Nickel-PTFE ME = Aluminum, Electroless Nickel TZ = Aluminum, Tin Zinc Z1 = Stainless Steel, Passivate					
Size and Layout	See Contact Arrangements Table					
Contact Style	P = Pin S = Socket					
Polarization	A, B, C, D, E, F, G, N (see Polarization Keys and Keyways table)					

SHELL SIZE / CONTACT ARRANGEMENTS (FACE OF PIN INSERT)			
11-1 • 1X #8	13-1 • 1X #4	15-1 • 1X #2	17-1 • 1X #1/0
17-2 • 2X #8	19-3 • 3X #8	21-4 • 4X #8	
23-2 • 2X #4	25-2 • 2X #2	25-4 • 4X #4	
15-3 • 1X #8 and 2X #20	17-3 • 1X #4 and 2X #20	19-A3 • 1X #2 and 2X #20	21-3 • 1X #1/0 and 2X #20

973-003 SuperNine Series III PowerPlay with Threaded Contacts
00, D0, CS Panel-Mount Receptacles

SUPER NINE SERIES III POWERPLAY TRIPLE-START

00, D0 AND CS PANEL-MOUNT AND IN-LINE RECEPTACLES

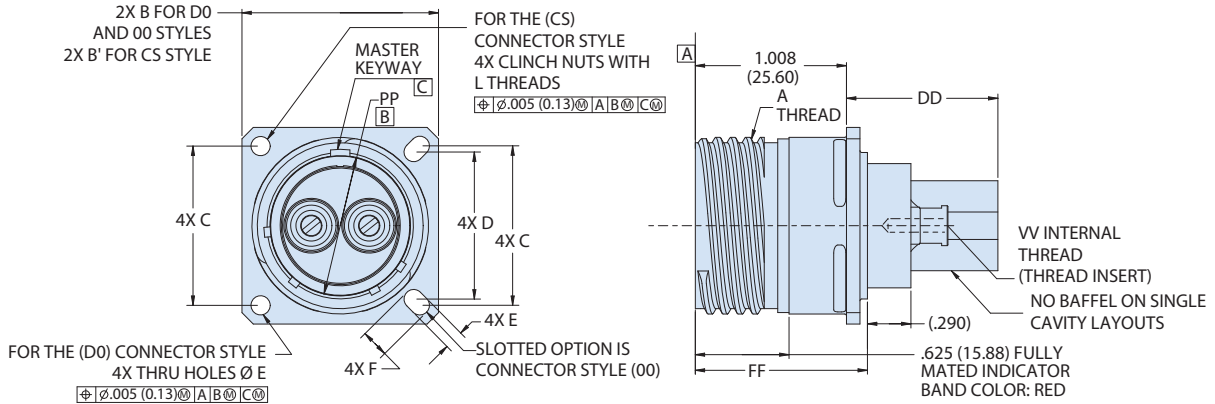

Shell Size	A Thread	B SQ	B' SQ	C BSC	D BSC	PP	E	F	L Thread	Ø M Max	DD Max.	FF 0.025	VV Thread
11-1	.7500-.1P-.3L-TS-2A	1.043 (26.49) 1.019 (25.88)	1.187 (30.15) 1.147 (29.13)	0.812 (20.62)	0.719 (18.26)	0.447 (11.35) 0.441 (11.20)				0.984 (24.99)	N/A	1.148 (29.16)	6-32 UNC
13-1	.8750-.1P-.3L-TS-2A	1.138 (28.91) 1.114 (28.30)	1.281 (32.54) 1.241 (31.52)	0.906 (23.01)	0.812 (20.62)	0.687 (17.45) 0.681 (17.30)				1.157 (29.39)	N/A	1.148 (29.16)	10-32 UNF
15-1	1.0000-.1P-.3L-TS-2A	1.232 (31.29)	1.293 (32.84)	0.969 (24.61)	0.906 (23.01)	0.812 (20.62)	0.136 (3.45)	0.202 (5.13)	.112-40 UNC-3B	1.280 (32.51)	N/A	1.310 (33.27)	1/4-28 UNF
15-3		1.208 (30.68)	1.253 (31.83)	(24.61)	(23.01)	0.804 (20.42)				1.148 (29.16)	6-32 UNC		
17-1	1.1875-.1P-.3L-TS-2A	1.323 (33.60)	1.386 (35.20)	1.062 (26.97)	0.969 (24.61)	0.937 (23.80)	0.120 (3.05)	0.186 (4.72)	.112-40 UNC-3B	1.406 (35.71)	N/A	1.310 (33.27)	5/16-24 UNF
17-2		1.299 (32.99)	1.346 (34.19)	(26.97)	(24.61)	0.930 (23.62)				1.040 (26.42)	1.148 (29.16)	6-32 UNC	
17-3										N/A	1.148 (29.16)	10-32 UNF	
19-3	1.2500-.1P-.3L-TS-2A	1.449 (36.80)	1.531 (38.89)	1.156 (29.36)	1.062 (26.97)	1.042 (26.47)				1.516 (38.51)	1.040 (26.42)	1.148 (29.16)	6-32 UNC
19-A3		1.425 (36.20)	1.491 (37.87)	(29.36)	(26.97)	1.036 (26.31)				N/A	1.310 (33.27)	1/4-28 UNF	
21-3	1.3750-.1P-.3L-TS-2A	1.575 (40.01)	1.625 (41.28)	1.250 (31.75)	1.156 (29.36)	1.167 (29.64)				1.642 (41.71)	N/A	1.310 (33.27)	5/16-24 UNF
21-4		1.551 (39.40)	1.585 (40.26)	(31.75)	(29.36)	1.161 (29.49)				1.040 (26.42)	1.148 (29.16)	6-32 UNC	
23-2	1.5000-.1P-.3L-TS-2A	1.701 (43.21) 1.677 (42.60)	1.750 (44.45) 1.710 (43.43)	1.375 (34.93)	1.250 (31.75)	1.295 (32.89) 1.286 (32.66)	0.162 (4.11)	0.250 (6.35)	.138-32 UNC-3B	1.768 (44.91)	1.150 (29.21)	1.148 (29.16)	10-32 UNF
25-2	1.6250-.1P-.3L-TS-2A	1.823 (46.30)	1.875 (47.63)	1.500 (38.10)	1.375 (34.93)	1.417 (35.99)	0.146 (3.71)	0.234 (5.94)	.138-32 UNC-3B	1.890 (48.01)	1.372 (34.85)	1.310 (33.27)	1/4-28 UNF
25-4		1.799 (45.69)	1.835 (46.61)	(38.10)	(34.93)	1.411 (35.84)				1.150 (29.21)	1.148 (29.16)	10-32 UNF	

POLARIZATION KEYS AND KEYWAYS					
Shell Size	Polarization Code	Minor Key/Keyway Rotation			
		A°	B°	C°	D°
11 13 15	N	95	141	208	236
	A	113	156	182	292
	B	90	145	195	252
	C	53	156	220	255
	D	119	146	176	298
	E	51	141	184	242
	F	77	141	220	273
17 19 21 23 25	G	66	156	176	236
	N	80	142	196	293
	A	135	170	200	310
	B	49	169	200	244
	C	66	140	200	257
	D	62	145	180	280
	E	79	153	197	272
F	95	150	180	235	
G	115	157	185	270	

PANEL CUT OUT FOR PANEL-MOUNT RECEPTACLES					
Shell Size	N Min.	P Min.	R Holes	S1 BSC	S2 BSC
11	.796 (20.22)	.625 (15.88)		.812 (20.62)	.719 (18.26)
13	.922 (23.42)	.750 (19.05)		.906 (23.01)	.812 (20.62)
15	1.047 (26.59)	.906 (23.01)	.133 (3.38)	.969 (24.61)	.906 (23.01)
17	1.219 (30.96)	1.016 (25.81)	.123 (3.12)	1.062 (26.97)	.969 (24.61)
19	1.297 (32.94)	1.141 (28.98)		1.156 (29.36)	1.062 (26.97)
21	1.422 (36.12)	1.266 (32.16)		1.250 (31.75)	1.156 (29.36)
23	1.547 (39.29)	1.375 (34.93)	.159 (4.04)	1.375 (34.93)	1.250 (31.75)
25	1.672 (42.47)	1.484 (37.69)	.149 (3.78)	1.500 (38.10)	1.375 (34.93)

Panel Thickness: .300 Max

973-003 SuperNine Series III PowerPlay with Threaded Contacts
00, D0, CS Panel-Mount Receptacles

SUPERNINE SERIES III POWERPLAY TRIPLE-START

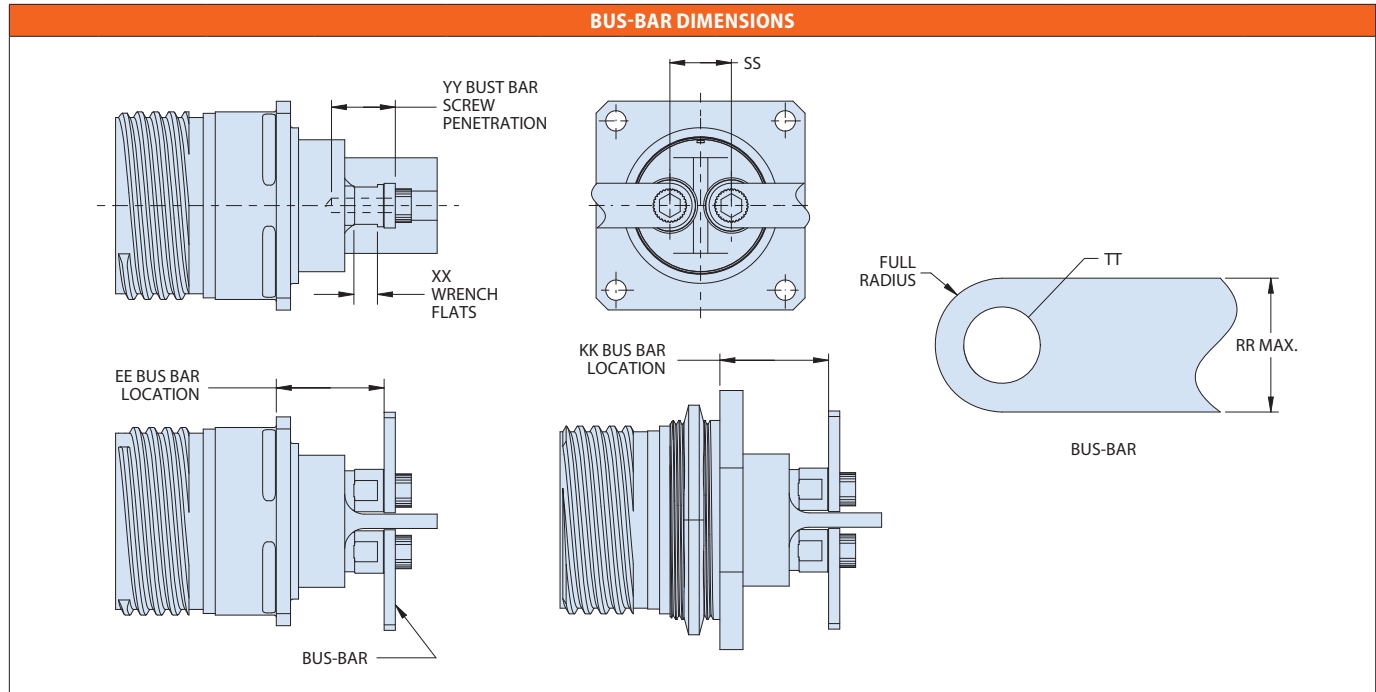

Shell Size	Ee ±.015	Kk ±.015	Rr	Tt ±.005	Ww	Xx	Yy	Ss	Recommended Torque (In. Lbs.)	Wrench Part Number
11-1	0.677 (17.20)	0.682 (17.32)	.265 (6.73) Max.	0.145 (3.68)	15/64"	0.140 (3.56)	.190 (4.83) Min./ .325 (8.26) Max.	N/A	8-10	979-008-8
13-1	0.677 (17.20)	0.682 (17.32)	.385 (9.78) Max.	0.197 (5.00)	5/16"	0.140 (3.56)	.410 (10.41) Min./ .560 (14.22) Max.	N/A	20-29	979-008-4
15-1	0.839 (21.31)	0.690 (17.53)	.475 (12.07) Max.	0.257 (6.53)	3/8"	0.140 (3.56)	.530 (13.46) Min./ .680 (17.27) Max.	N/A	60-70	979-008-2
15-3	0.677 (17.20)	0.682 (17.32)	.265 (6.73) Max.	0.145 (3.68)	15/64"	0.140 (3.56)	.190 (4.83) Min./ .325 (8.26) Max.	N/A	8-10	979-008-8
17-1	0.881 (22.38)	0.732 (18.59)	.595 (15.11) Max.	0.320 (8.13)	1/2"	0.190 (4.83)	.650 (16.51) Min./ .800 (20.32) Max.	N/A	90-140	979-008-0
17-2	0.677 (17.20)	0.682 (17.32)	.265 (6.73) Max.	0.145 (3.68)	15/64"	0.140 (3.56)	.190 (4.83) Min./ .325 (8.26) Max.	0.386	8-10	979-008-8
17-3	0.677 (17.20)	0.682 (17.32)	.385 (9.78) Max.	0.197 (5.00)	5/16"	0.140 (3.56)	.410 (10.41) Min./ .560 (14.22) Max.	N/A	20-29	979-008-4
19-3	0.677 (17.20)	0.682 (17.32)	.265 (6.73) Max.	0.145 (3.68)	15/64"	0.140 (3.56)	.190 (4.83) Min./ .325 (8.26) Max.	0.390	8-10	979-008-8
19-A3	0.839 (21.31)	0.690 (17.53)	.475 (12.07) Max.	0.257 (6.53)	3/8"	0.140 (3.56)	.530 (13.46) Min./ .680 (17.27) Max.	N/A	60-70	979-008-2
21-3	0.881 (22.38)	0.732 (18.59)	.595 (15.11) Max.	0.320 (8.13)	1/2"	0.190 (4.83)	.650 (16.51) Min./ .800 (20.32) Max.	N/A	90-140	979-008-0
21-4	0.677 (17.20)	0.682 (17.32)	.265 (6.73) Max.	0.145 (3.68)	15/64"	0.140 (3.56)	.190 (4.83) Min./ .325 (8.26) Max.	0.381	8-10	979-008-8
23-2	0.677 (17.20)	0.682 (17.32)	.385 (9.78) Max.	0.197 (5.00)	5/16"	0.140 (3.56)	.410 (10.41) Min./ .560 (14.22) Max.	0.540	20-29	979-008-4
25-2	0.839 (21.31)	0.690 (17.53)	.475 (12.07) Max.	0.257 (6.53)	3/8"	0.140 (3.56)	.530 (13.46) Min./ .680 (17.27) Max.	0.600	60-70	979-008-2
25-4	0.677 (17.20)	0.682 (17.32)	.385 (9.78) Max.	0.197 (5.00)	5/16"	0.140 (3.56)	.410 (10.41) Min./ .560 (14.22) Max.	0.503	20-29	979-008-4