

Series 970 PowerTrip™

Connectors and Accessories 850-311 Pin Contact Bus Bar/Lug

HOW TO ORDER				
Sample Part Number	850-311	-00	-A	-2
Basic Number	850-311 Pin Contact Bus Bar/Lug			
Contact Size	See Dimensions Table			
Termination Style	A = Internal Thread C = Lug			
Contact Plating	1 = Silver per ASTM B700, .0002 min over nickel 2 = Gold per ASTM B488, .000050 min over nickel			

MATERIAL AND FINISH

- Contact body: High conductivity copper alloy: See Dimensions Table

NOTES

- Contacts are intended to be installed into standard 970 Series powertrip plug and receptacle connectors

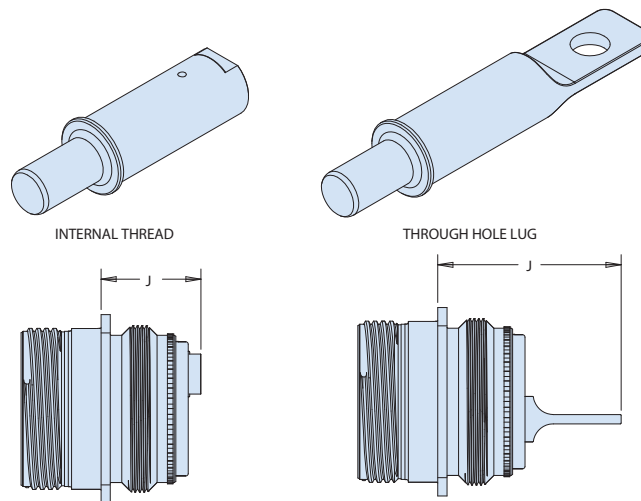

Contact Extension From Front Of Shell Flange. 970-003 Square Flange Housing Shown For Reference. Dimension Applies To Standard Length Connectors.

Orientation Of Contacts Shown For Reference. Contacts Are Not Keyed Into The Insert.

(TERMINATION STYLE A AND B) SUGGESTED HARDWARE TORQUE	
Thread Size	Torque (IN-LB)
5/16-24 UNF	90-140
10-32 UNF	20-29
8-36 UNF	11-19

Connectors and Accessories

850-311 Pin Contact Bus Bar/Lug

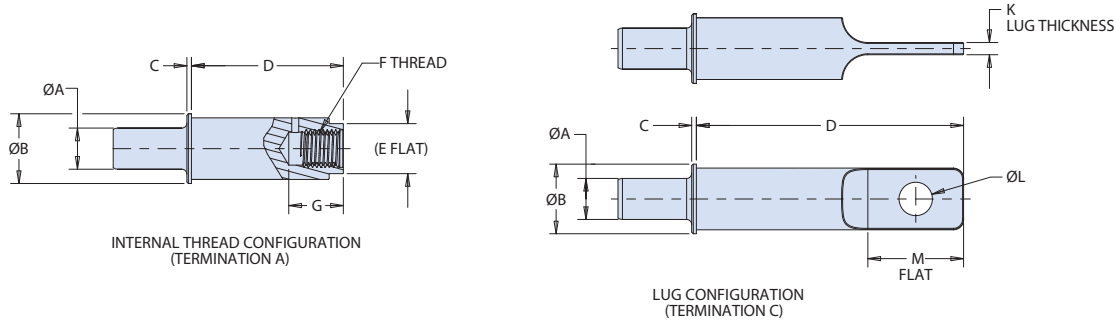

DIMENSIONS												
Part Number	Contact Size	Termination Style	$\varnothing A$	$\varnothing B$	C	D	E Flat (REF)	F Thread	G	H Max	J .025	
850-311-00-A-*	00	Internal Thread Style "A"	0.406 (10.31)	0.688 (17.48)	0.046 (1.17)	1.500 (38.10)	(1/2")	5/16-24 UNF 2B	0.539 (13.69)	N/A	1.356 (34.44)	1.231 (31.27)
850-311-0-A-*	0		0.357 (9.07)	0.613 (15.57)	0.046 (1.17)	1.376 (34.95)	(1/2")	5/16-24 UNF 2B	0.539 (13.69)		1.232 (31.29)	1.107 (28.12)
850-311-4-A-*	4		0.225 (5.72)	0.415 (10.54)	0.046 (1.17)	1.376 (34.95)	(5/16")	10-32 UNF 2B	0.460 (11.68)			
850-311-8-A-*	8		0.142 (3.61)	0.305 (7.75)	0.031 (0.79)	1.277 (32.44)	(1/4")	8-36 UNF 2B	0.407 (10.34)			
850-311-00-C-*	00	Lug Style "C"	0.406 (10.31)	0.688 (17.48)	0.046 (1.17)	2.640 (67.06)	N/A	N/A	N/A	N/A	2.496 (63.40)	2.371 (60.22)
850-311-0-C-*	0		0.357 (9.07)	0.613 (15.57)	0.046 (1.17)	2.406 (61.11)					2.262 (57.45)	2.137 (54.28)
850-311-4-C-*	4		0.225 (5.72)	0.415 (10.54)	0.046 (1.17)	2.122 (53.90)					1.978 (50.24)	1.853 (47.07)
850-311-8-C-*	8		0.142 (3.61)	0.305 (7.75)	0.031 (0.79)	1.889 (47.98)					1.844 (46.84)	1.719 (43.66)

DIMENSIONS				
Contact Size	Termination Style	K	$\varnothing L$	M Flat
00	Lug Style "C"	.120 (3.05)	.330 (8.38)	.946 (24.03)
0		.115 (2.92)	.330 (8.38)	.836 (21.23)
4		.085 (2.16)	.198 (5.03)	.552 (14.02)
8		.075 (1.90)	.173 (4.39)	.468 (11.89)