

SPRING ACTION

ProSeal™ environmental connector covers



for MIL-DTL-38999 Series III / SuperNine® connectors
Pressure seal, dust and immersion resistant

667-449 PROSEAL PROTECTIVE COVER FOR D38999 SERIES III CONNECTORS

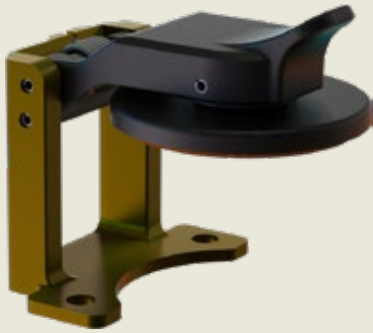

How to Order 667-449					
Sample Part Number	667-449	NF	17	T1	J
Series	ProSeal protective cover for D38999 Series III connectors				
Material / Finish	See Table II				
Shell Size	See Table I				
Panel Thickness	See Table III				
Type of Mounting	J = Jam Nut Mount Receptacle W = Wall Mount Receptacle				

- Pressure seal, dust and immersion resistant
- Self-aligning
- Positive spring-action in closed position. Locks open at approximately 105° from receptacle face.

Wall mount, shown closed

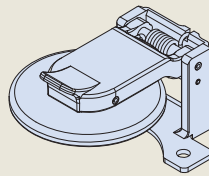

Jam nut mount, shown open

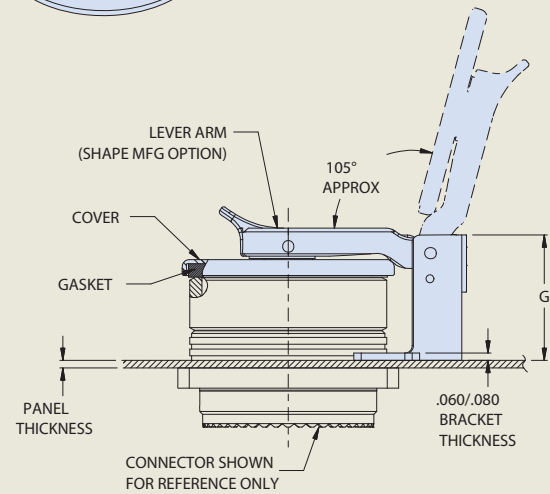
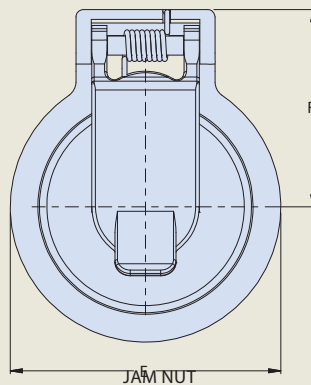
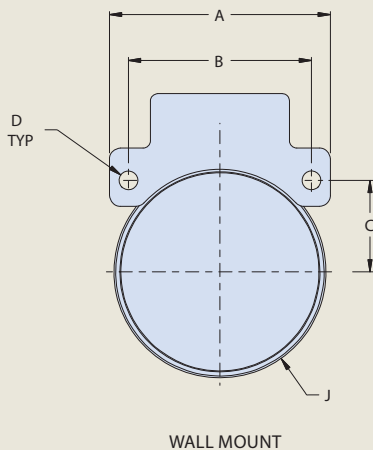
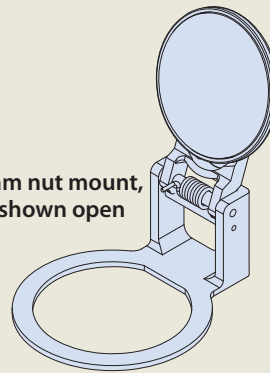

MATERIAL / FINISH

- Cover, Lever Arm, Gimbal - Thermoplastic / Black
- Bracket - see Table II
- Spring / Pin / Rivet - 300 Series SST / Passivate
- Sleeve - Delrin
- Gasket - Silicone (optional)



Table I: Dimensions														
Shell Size	A Dim max		B Dim		C Dim		D ±.008 (.20)		E ±.031 (.79)		F Dim max		J Dia max	
	in	mm	in	mm	in	mm	in	mm	in	mm	in	mm	in	mm
09	0.937	23.80	0.719	18.26	0.360	9.14	0.128	3.25	1.031	26.19	.913	23.19	.735	18.67
11	1.031	26.19	0.812	20.62	0.406	10.31	0.128	3.25	1.125	28.58	.961	24.41	.860	21.84
13	1.126	28.60	0.906	23.01	0.453	11.51	0.128	3.25	1.375	34.93	1.083	27.51	.985	25.02
15	1.220	30.99	0.969	24.61	0.485	12.32	0.128	3.25	1.560	39.62	1.178	29.92	1.120	28.45
17	1.311	33.30	1.062	26.97	0.531	13.49	0.128	3.25	1.625	41.28	1.211	30.76	1.280	32.51
19	1.437	36.50	1.156	29.36	0.578	14.68	0.128	3.25	1.750	44.45	1.273	32.33	1.343	34.11
21	1.563	39.70	1.250	31.75	0.625	15.88	0.128	3.25	2.000	50.80	1.538	39.07	1.466	37.24
23	1.689	42.90	1.375	34.93	0.688	17.48	0.154	3.91	2.150	54.61	1.614	41.00	1.593	40.46
25	1.841	46.76	1.500	38.10	0.750	19.05	0.154	3.91	2.218	56.34	1.647	41.83	1.718	43.64

Table II: Material and Finish		
Sym	Material	Finish
MT	Aluminum	Nickel-PTFE
ZR		Zinc-Nickel, Black (Tri-Valent CR)
M		Electroless Nickel
NF		Cad Plate / Olive Drab over Electroless Nickel
C		Anodize / Black
UC		Zinc Cobalt / Black

Table III: Panel Thickness							
Dash No.	Panel Thickness* ±.030 (.76)		Shell Size	G ± .06			
	in	mm		Jam Nut Mount		Wall Mount	
				in	mm	in	mm
T0	.000	.00	09-19	N/A	N/A	1.039	26.39
			21-25	N/A	N/A	1.094	27.79
T1	.062	1.57	09-19	1.041	26.44	0.977	24.82
			21-25	1.126	28.60	1.032	26.21
T2	.125	3.18	09-19	0.979	24.87	0.915	23.24
			21-25	1.064	27.03	0.970	24.64

*Jam nut mount is not available with panel thickness T0

38999 Series III / SuperNine