

QwikConnect[®]

GLEN AIR • APRIL 2026 • VOLUME 30 • NUMBER 2

Satellite Interconnect Architectures:
CONNECTING THE SATELLITE BUS
TO THE MISSION PAYLOAD



Satellite Interconnect Architectures: CONNECTING THE SATELLITE BUS TO THE MISSION PAYLOAD





In satellite architecture, mission hardware is divided into two fundamental elements: the payload, which performs the mission function, and the spacecraft bus, the supporting platform that provides power, command and data handling, thermal control, propulsion, communications, and structural support. The interface between these two domains is enabled by a complex network of electrical and fiber optic interconnects that distribute power, route high-speed data, and carry command and telemetry signals. Designing these interconnect interfaces to meet the stringent requirements of the space environment—while maintaining reliability and signal integrity—constitutes a central challenge in modern spacecraft engineering.

Individual satellites and satellite constellations must perform flawlessly in an environment that is simultaneously mechanically violent, electrically complex, and thermally extreme. Once deployed in orbit, repair is effectively impossible. Reliability must therefore be engineered into every connector, cable assembly, and harness interface from the start.

To meet these challenges, Glenair has adopted an ecosystem approach to the design of space-grade interconnects and wire harnessing—an integrated architecture of cables, connectors, assemblies, and mechanisms engineered in concert for reliable life-of-system performance. Rather than viewing connectors, contacts, and harnesses as individual components, the ecosystem model considers how every electrical pathway interacts with spacecraft subsystems, mission payloads, and the unique environmental zones of the satellite itself.

Before exploring these technologies in detail, it is useful to examine the application environment and the fundamental architecture that defines modern satellite systems.



The Satellite Bus and the Mission Payload

At the most basic level, the architecture of any satellite consists of two integrated elements: The spacecraft bus and the mission payload.

The spacecraft bus provides the foundational infrastructure that allows the satellite to operate in orbit. It includes the vehicle's structural framework and all supporting subsystems required for sustained operation: Structural elements and mounting interfaces; thermal control systems; electrical power generation and distribution; onboard flight computers and command/data handling electronics; propulsion and orbital maneuvering systems; attitude determination and control systems; and communications and telemetry equipment. In essence, the bus is the satellite's life-support system, providing power, stability, environmental control, and command capability for every onboard function.

The payload, by contrast, is the mission-specific equipment responsible for accomplishing the satellite's purpose. Payload configurations vary depending on mission objectives. An Earth observation satellite may carry high-resolution cameras, multispectral imaging systems, or synthetic aperture radar instruments. A communications satellite typically houses transponders, amplifiers, and high-gain antennas for broadband signal relay. Scientific missions may incorporate magnetometers, particle detectors, spectrometers, or atmospheric probes.

Although the bus and payload are conceptually distinct, their operational effectiveness depends in large part on the electrical and mechanical interconnect architecture that links them together. This is the subject of this special issue of *QwikConnect*.

This communications satellite diagram identifies the principal satellite bus subsystems that support the mission payload. Source: *The Efficient Engineer* www.youtube.com/@TheEfficientEngineer

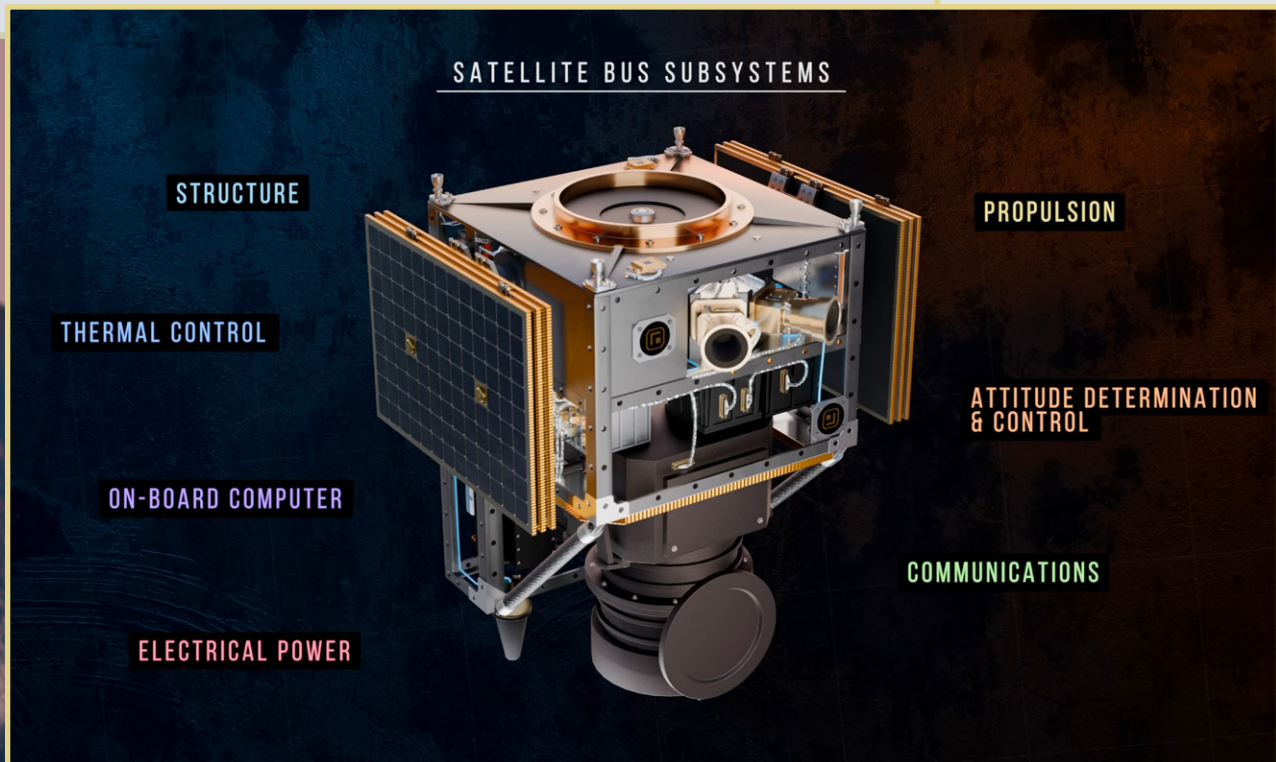

Four branded wire families form the basis for the Glenair ecosystem approach to the interconnection of satellite bus / payloads, as well as—in the case of RF—operations internal to the payload such as radar and RF receiver chains.



SpeedLine
Controlled-Impedance Cables

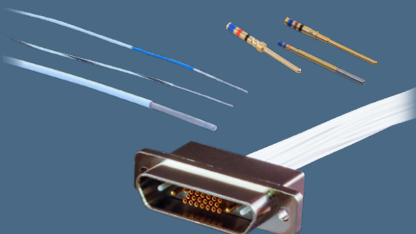

MIL-STAR
HIGH-PERFORMANCE HOOKUP WIRE AND CABLE



turboflex
THE ULTRA FLEXIBLE RUGGED POWER CABLE



BLUMARK
COAX CABLES **RF**

Four Primary Wiring Types in Satellite Interconnect Systems

Electrical integration between the spacecraft bus and the payload is typically achieved through four fundamental classes of wiring: high-speed digital data, low-speed digital and discrete signaling, electrical power distribution, and RF/microwave transmission. Each category supports a distinct class of spacecraft function and requires specialized cable construction, shielding, and connector technologies.

HIGH-SPEED DIGITAL DATA

High-speed digital cabling carries mission data and high-bandwidth communications between payload electronics, processors, and onboard data-handling systems. These interconnects utilize controlled-impedance shielded differential pairs designed to meet modern communication standards. Glenair SpeedLine™ assemblies employ precise impedance control, advanced shielding architectures, and low-loss insulation materials to support 10 Gigabit Ethernet and other high-speed data buses used in modern spacecraft avionics. Maintaining signal integrity in these networks requires careful attention to cable geometry, shielding effectiveness, connector termination, and electromagnetic compatibility.

COMMAND, CONTROL, AND DISCRETE I/O SIGNALING

Low-speed digital and discrete wiring supports spacecraft command, control, and housekeeping functions—monitoring voltages, temperatures, currents, and subsystem health. Glenair MIL-STAR™ wiring supports standard spacecraft interfaces including RS-422 and similar serial control buses. These cables are available in conventional and cross-linked insulation constructions and may incorporate specialized plating systems to address long-term corrosion risks. For example, thick 2-micron silver plating mitigates red plague, while low-fluoride insulation systems reduce susceptibility to white plague in harsh environments.

ELECTRICAL POWER DISTRIBUTION

Electrical power cabling distributes energy from solar arrays and onboard batteries to propulsion systems, avionics boxes, sensors, communications equipment, and payload instruments throughout the satellite. Glenair TurboFlex™ power cables and assemblies are designed to carry high current loads while remaining lightweight, flexible, and resistant to environmental damage.

RF AND MICROWAVE TRANSMISSION

High-frequency RF and microwave cabling supports command uplinks, telemetry downlinks, and mission data transmission between the satellite and ground stations, as well as internal payload functions such as radar and receiver chains. Glenair BluMark™ RF coax cables are engineered for minimal signal loss, stable impedance, and resistance to radiation and thermal extremes within payload electronic systems.

Turnkey Space-Grade Harness Assembly

All of these wire types—along with compatible connectors and termination technologies—are available as fully integrated harness assemblies manufactured in conventional and controlled cleanroom environments.

Glenair's Space Systems facility in Salem, Germany, specializes in the fabrication of space-grade harness assemblies including Micro-D, nano-miniature, and other small form-factor connector systems used in modern spacecraft. The capability includes highly-engineered **cryogenic harnesses** fabricated from ultra small-gauge Niobium-Titanium and other low thermal-conductivity wire and connector materials.

These assemblies support applications ranging from serial data bus integration and avionics connectivity to high-speed digital networks and RF payload interconnection. Cryogenic cables support such applications as infrared sensors and cameras and thermal imaging devices.

Cleanroom and tightly-controlled conventional fabrication ensures contamination control and process traceability—critical factors in space-flight hardware qualification.

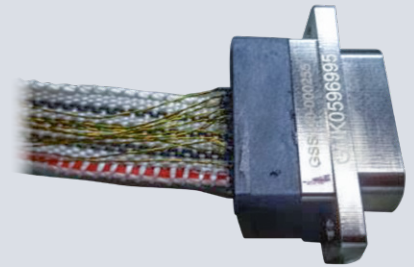

Glenair operates space harness assembly facilities worldwide, including ISO 8 and ISO 6 clean rooms, a certified ISO 5 flow chamber, and ample accommodation for any size mockup and integration for satellite harnesses. Glenair cable assemblies have space flight heritage in active satellite and satellite constellations. Image: Turnkey crimp-contact Micro-D cryogenic cable harness for a low thermal conductivity infrared camera payload application.



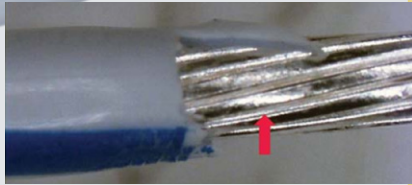
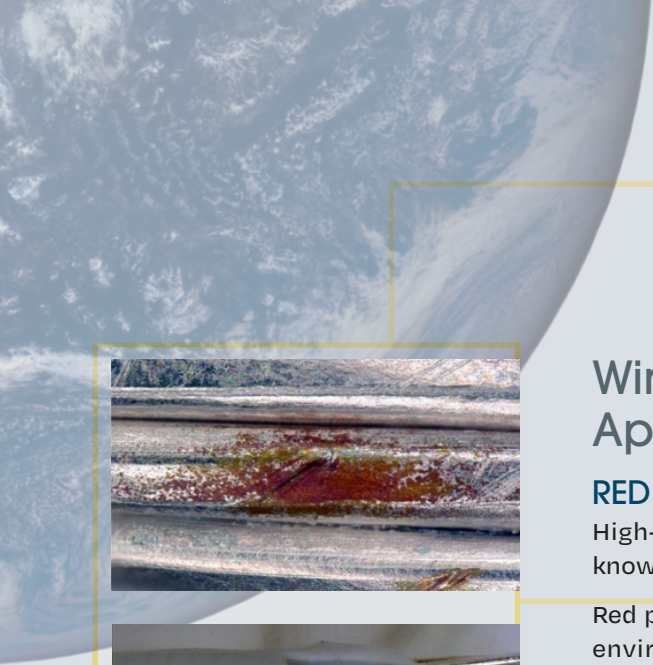

Red plague corrosion (top) and White plague can cause degradation and electrical failure in electrical wire interconnect systems. Glenair MIL-STAR wire customers may specify Mod Code 1304B for thicker 80 microinch silver plating on wire conductors to mitigate red plague risks, and low-fluoride XL-ETFE wire insulation to reduce the potential for fluoride-related white plague corrosion.
Photos: NASA

Wire Corrosion Resistance in Satellite Applications

RED PLAGUE AND WHITE PLAGUE IN AEROSPACE WIRING

High-reliability aerospace wiring systems must contend with two well-known corrosion phenomena: red plague and white plague.

Red plague is a copper oxide corrosion process that occurs in pre-launch environments when moisture penetrates silver-plated copper conductors through cracks or damage in the plating layer. The resulting cuprous oxide corrosion product has a characteristic reddish color and can propagate along the conductor strands, eventually degrading conductivity and causing electrical failure.

White plague is a different corrosion mechanism associated with certain fluoropolymer wire insulation systems. In the presence of moisture and elevated temperatures, fluorine compounds can contribute to reactions with silver-plated conductors resulting in white, powdery silver fluoride residue.

Mitigation strategies include optimized plating thickness, improved insulation chemistry, and controlled manufacturing processes. For example, Glenair customers may specify thicker 2-micron silver plating and low-fluoride XL-ETFE MIL-STAR wiring—both of which are widely used in space-grade wiring to reduce these corrosion mechanisms.

Advanced Temperature and Durability in Satellite Wire Systems

CROSSLINKED WIRE INSULATION FOR SPACE APPLICATIONS

Wire insulation used in spacecraft must maintain mechanical integrity and electrical performance across a wide range of environmental conditions.

Crosslinked insulation materials are widely used in aerospace wiring because they provide enhanced resistance to heat, radiation, and mechanical stress.

Crosslinking is achieved through processes such as electron-beam irradiation, which creates chemical bonds between polymer chains in the insulation material. This transformation improves:

- ▷ Temperature resistance
- ▷ Chemical stability
- ▷ Abrasion resistance
- ▷ Resistance to radiation degradation

Crosslinked ETFE and other advanced fluoropolymer insulations are commonly used in space-grade wiring systems, particularly in harnesses exposed to the external spacecraft environment.

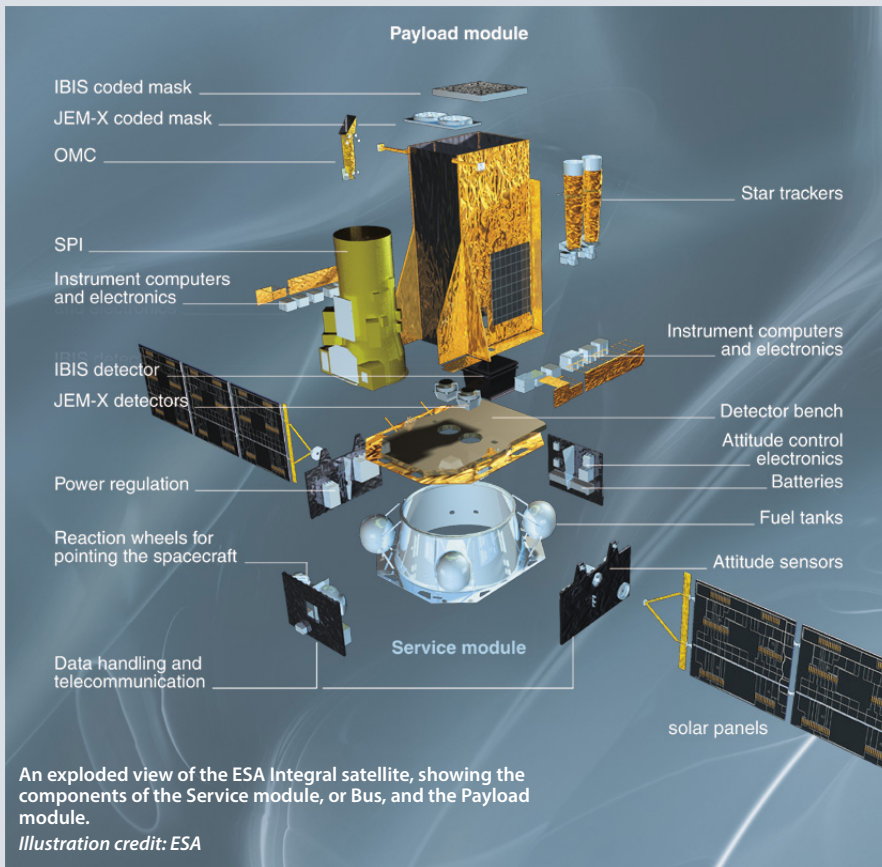

Modular Satellite Bus and Payload Interfaces

Satellite design is moving rapidly toward spacecraft architectures that allow modular payloads, avionics, and subsystem components to be easily and consistently integrated across multiple spacecraft platforms. A modular approach—with functionally consistent interconnect interfaces—shortens development timelines, reduces integration complexity, and enables spacecraft buses to support a wide range of missions with accelerated development cycles.

Several industry initiatives have explored functionally standard payload interface concepts. One emerging example is the Handle 2.0 initiative, which proposes a modular spacecraft interface architecture intended to simplify payload integration through common electrical services and connector layouts. While still evolving, the concept reflects a broader industry trend toward payload interfaces built around Ethernet data networks, distributed power delivery, and standardized connector architectures. Numerous other data bus and network architectures exist such as MIL-STD-1553, SpaceWire, and SpaceFibre.

At a practical level, these satellite interconnect system architectures depend on a physical layer of connectors, contacts, and wire harness assemblies capable of carrying signals and power reliably throughout the spacecraft. Nearly all payload interfaces ultimately support three essential electrical services: high-speed digital data communication, electrical power distribution, and discrete command, control, avionics, and sensor signaling. Let's take a look at some specific Glenair interconnect technologies—with proven reliability and space heritage—that are currently being deployed in each of these critical satellite bus-to-payload interconnect system roles.

Satellite Payload Interfaces: Three Essential Services

- ▶ High-speed digital data communication
- ▶ Electrical power distribution
- ▶ Command, control, avionics, and sensor signaling

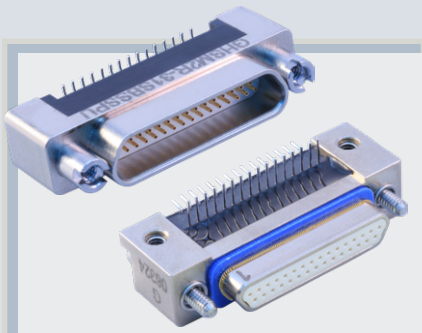

Why Ethernet is Growing in Spacecraft Payload Interfaces

Ethernet is emerging as a viable architecture for spacecraft data networks because it combines high bandwidth with a mature ecosystem of switching hardware and communication protocols. Unlike legacy spacecraft buses designed for specific missions, Ethernet enables distributed avionics systems in which payload processors, sensors, and control electronics communicate across a common network. This flexibility simplifies spacecraft integration and allows payload modules to be reused across multiple spacecraft platforms. High-density connectors such as GHSM High-Speed Micro-D provide the controlled-impedance differential pair routing required to maintain signal integrity in these high-speed avionics networks.

Board-Level High-Speed Digital Data Communication

GHSM AND GMMD HIGH-SPEED MICRO-D CONNECTORS

Modern payload instruments generate enormous volumes of data that must be transmitted to onboard processors, avionics systems, and communication subsystems. Ethernet has therefore become one of the preferred architectures for spacecraft data networks. Its mature switching infrastructure, widely supported protocols, and scalability across distributed avionics systems make it well suited to modular satellite platforms.

Ethernet signals are transmitted through controlled-impedance differential pairs (Glenair SpeedLine) that must maintain signal integrity to and from payload and satellite bus electronic equipment, as well as from I/O interfaces to the board. Inside spacecraft avionics enclosures, high-density rectangular connectors such as Glenair GHSM High-Speed Micro-D and GMMD maintain signal integrity in board-to-board and I/O-to-board configurations.

GHSM connectors support tightly-controlled differential pair routing in compact packages, enabling reliable high-speed communication between flight computers, processing modules, and subsystem electronics. Their high contact density and excellent electrical performance make them particularly well suited to the high-speed data links that increasingly define board-level spacecraft avionics.

For applications requiring flexible internal wiring layouts, designers may also incorporate Glenair Modular Micro-D (GMMD) connectors. GMMD modules allow engineers to specify familiar Micro-D interconnect arrangements while incorporating high-speed differential data pairs for 10Gb Ethernet and other controlled-impedance protocols.

Together, these Micro-D solutions support the board and backplane interconnect requirements for countless spacecraft high-speed digital communication architectures.

High-Speed Digital Data

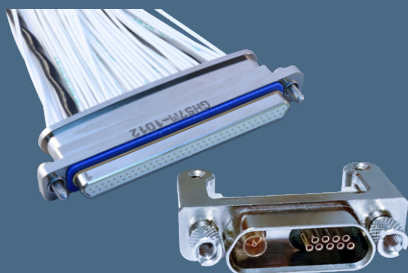

High-Speed Micro-D · GMMD

Electrical Power Distribution

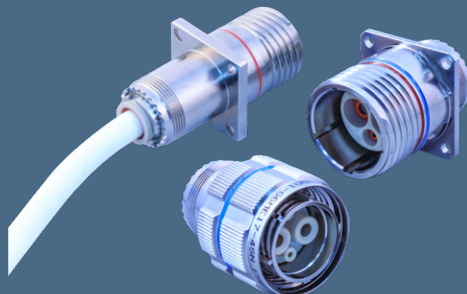

SuperNine PowerPlay · TurboFlex

Databus Signaling



Series 806 Mil-Aero

System-to-System Level Electrical Power Distribution

TURBOFLEX AND SUPERNINE POWERPLAY HYBRID POWER AND DATA INTERCONNECTIONS

In addition to high-speed data communication, payload interfaces must deliver electrical power from the spacecraft bus to payload instruments and subsystem electronics.

Many payload interfaces deliver both low-to-moderate power distribution as well as low-power digital signaling through contacts and wiring in the 22–28 AWG range. Spreading current across multiple contacts improves thermal performance, enhances redundancy, and allows spacecraft integrators to scale power capacity across different payload configurations.

Certain spacecraft subsystems require significantly higher current capacity. Electric propulsion systems, high-power RF transmitters, optical payload instruments, and advanced onboard processors can all place substantial demands on spacecraft power distribution systems. For these applications, Glenair PowerPlay connectors provide a scalable solution with contact sizes ranging from #22D to 4/0. The series is supplied in four interconnect packaging options, SuperNine Series I and III D38999-type, Series 806 micro miniature circular, and Series 971 high-performance rectangular. kVDC high-voltage kV Seal™ contacts for use in spacecraft propulsion systems are supported in all designs.

I/O and Wire-Harness Level Command, Control, and Avionics Signaling

SERIES 806 AND 806B MIL-AERO CONNECTORS

In addition to high-speed data and high-current power delivery, the satellite bus and payload interface must also support low-speed databus signals used for command, telemetry, and housekeeping functions.

These circuits include subsystem control lines, payload status indicators, and other operational signals exchanged between payload instruments and spacecraft avionics systems. Although these circuits typically carry relatively low current, they must be routed through connectors capable of maintaining electrical integrity under launch vibration, thermal cycling, and long-duration orbital operation.



Why Crown-Ring Contacts Excel in Spacecraft Power Systems

Delivering electrical power through spacecraft connectors requires low contact resistance, strong mechanical retention, and reliable performance under vibration and thermal cycling. Crown-ring contacts achieve this by using multiple circumferential spring elements that create a large and stable electrical contact surface. The result is lower resistance, improved heat dissipation, and higher current capacity compared with traditional contact designs. These characteristics make crown-ring contacts particularly well suited to demanding spacecraft subsystems such as electric propulsion and high-power RF systems. Connectors such as Series 806B incorporate crown-ring contacts to provide compact, high-current power interfaces for modern spacecraft architectures.

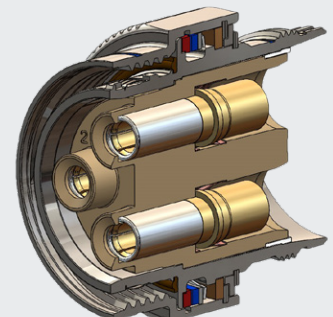

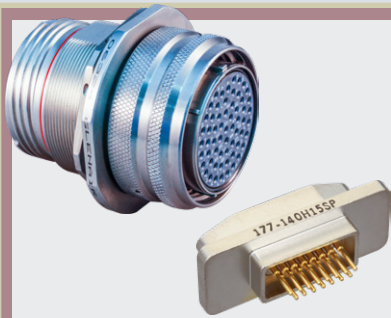

Why Hermetic Connectors Matter in Spacecraft

Hermetic connectors are essential components in spacecraft systems where environmental isolation must be maintained between compartments.

These connectors utilize glass-to-metal or epoxy sealing technologies to create leak-tight electrical feedthroughs for pressure boundaries or sealed avionics enclosures. The hermetic seal prevents gas leakage, moisture ingress, and contamination transfer between compartments.

Hermetic interconnects play several critical roles in spacecraft systems:

- ▶ Preserving dry nitrogen backfills inside avionics enclosures prior to launch
- ▶ Maintaining insulation resistance in sensitive electronics packages
- ▶ Supporting thermal vacuum testing during spacecraft qualification
- ▶ Managing long-term leak rates during multi-year missions in orbit

Hermetic connector packaging commonly used in space systems include D-Sub, Micro-D, and D38999 circular connectors. Special cryogenic hermetics meet the need for extreme low-temperature tolerance in external-zone space applications.

Compact circular connectors such as Glenair Series 806 (triple-start stub ACME) and 806B (bayonet) connectors are widely used for these payload I/O interfaces. Both designs combine rugged circular shells with removable crimp contacts and flexible hybrid insert arrangements, allowing designers to integrate discrete signal contacts alongside high-speed differential pair shielded contact and power contacts when required.

In many spacecraft architectures, Series 806 and 806B connectors serve as the primary payload interface, carrying command signals, telemetry, Ethernet differential pairs, as well as distributed power circuits through a single connector interface.

Hybrid Connectors: One Interface Package for High-Speed Data, Power, and Signal Interconnects

Hybrid connectors—both space-grade environmental and hermetic—combine the three principal contact and wire types—differential pairs for high-speed data, signal contacts for command and telemetry circuits, and specialized power contacts for power distribution—within a single connector insert. This approach reduces connector count, simplifies harness routing, and improves overall system reliability. Compact circular connectors such as Glenair SuperNine and Series 806 Mil-Aero, and Series 79 Micro-Crimp rectangular may be easily configured with hybrid inserts, allowing spacecraft designers to integrate Ethernet communication, discrete signals, and distributed power delivery through a single rugged payload interface.

A broad range of circular and rectangular connectors from Glenair have also been optimized with hybrid contact layouts that combine standard signal contacts with 20HD Power contacts and El Ochito octaxial shielded contacts for 10Gb Ethernet applications, enabling high-speed data, power, and discrete signals to coexist within compact harness designs. This flexibility helps spacecraft integrators further reduce connector count while streamlining payload-to-satellite bus harness architecture. Furthermore, as satellite programs increasingly adopt modular spacecraft architectures, scalable hybrid interconnect systems such as those described here will become ever more essential to rapid payload integration across the next generation of spacecraft platforms.

Hybrid Payload-to-Bus Architectures Optimized for Size, Weight, and Power

Glenair fields a highly popular payload-to-satellite bus interconnect architecture: a Series 805 circular Mighty Mouse equipped with El Ochito 10Gb Ethernet shielded contacts, size #23 39029 crimp signal contacts, and special size #22 Crown Ring contacts for up to 10 Amps of power. This TRL9 solution is in active use in LEO satellite constellations, and is compatible with emerging standards such as Handle 2.0 for payload-to-bus interconnections. Glenair is able to supply a signature range of other form-factor interconnects as well, including higher-amperage power solutions, high-speed digital data up to 28Gbps, plus in-house controlled-impedance cable with lightweight shielding. Here are two of these unique interface architectures:



HYBRID PAYLOAD-TO-BUS ARCHITECTURE OPTIMIZED FOR SWAP: SERIES 806 MIL-AERO AND GHSM OR GMMD HIGH-SPEED MICRO-D

In this architecture the modular payload connects to the spacecraft bus through a hybrid circular connector optimized for weight and size reduction. High-speed data and control / telemetry signals plus power are routed through the spacecraft harness and distributed internally to power supplies and avionics equipment through high-density, high-signal-integrity circular or Micro-D rectangular connectors.

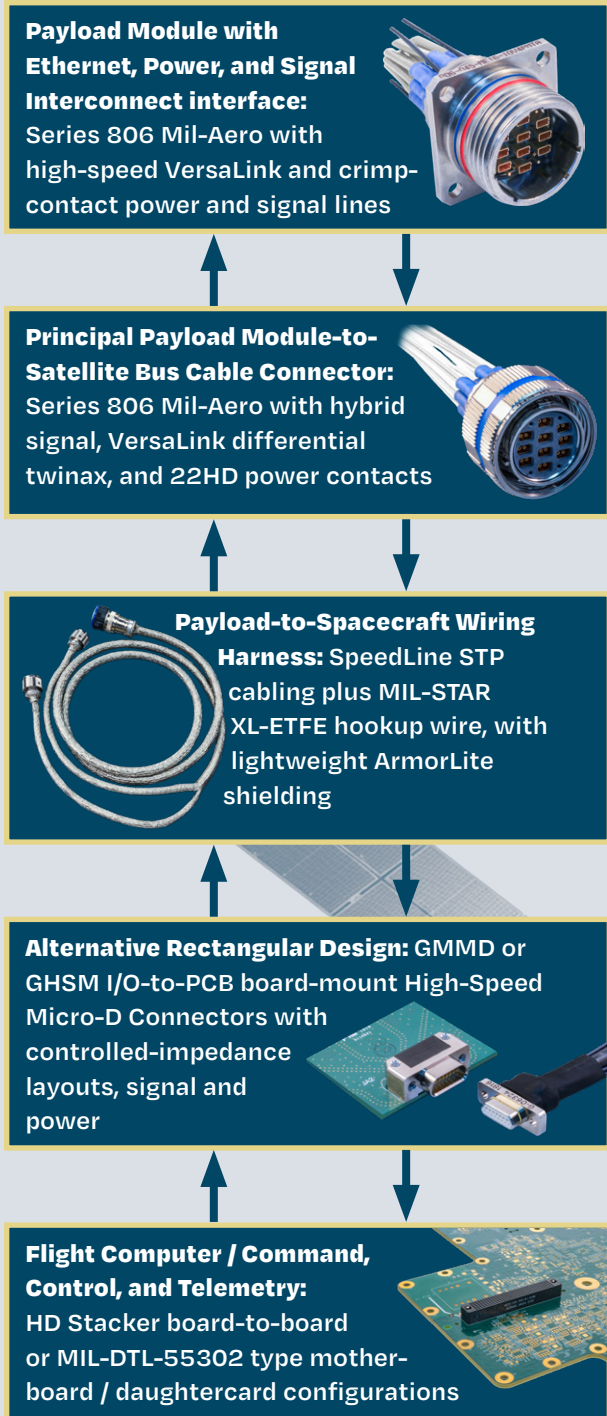

PAYLOAD-TO-BUS POWER ARCHITECTURES: SERIES 806B POWERPLAY, SERIES 971 POWERPLAY, OR SUPERNINE POWERPLAY

This configuration enables significantly higher current delivery while maintaining rugged electrical contact between payload elements and the satellite bus. Glenair Series 971 PowerPlay rectangular is offered in hybrid arrangements with both size #8 Crown Ring contacts and size #20 signal. Circular PowerPlay versions are high-power only.



Interconnect Zones in Spacecraft Design

Much like in aircraft systems, electrical interconnect architectures in spacecraft are often defined by the environmental zones in which they operate. Each region exposes connectors and harnesses to different stress factors, requiring specialized materials, sealing strategies, and mechanical designs. Typical spacecraft interconnect zones include the external environment, enclosure penetrations, internal avionics compartments, deployment and separation interfaces, and ground test and integration systems. Understanding the environmental demands of each zone is essential for selecting appropriate connector technologies and harness materials.

EXTERNAL ZONE

The external zone, where hardware is directly exposed to the space environment, is the most hostile region for spacecraft interconnect systems. In orbit, connectors and harnesses operate in high vacuum while enduring ultraviolet radiation, atomic oxygen, and plasma interactions. Temperatures swing dramatically between deep cold during eclipse and intense solar heating in sunlight. Interconnect systems in this zone are optimized for survivability in both high heat and cryogenic extremes. Solutions include cross-linked wire insulation, robust EMI shielding, corrosion-resistant bonding paths, and temperature/radiation-tolerant connector shell and dielectric materials such as Glenair ThermaRex Cryo.

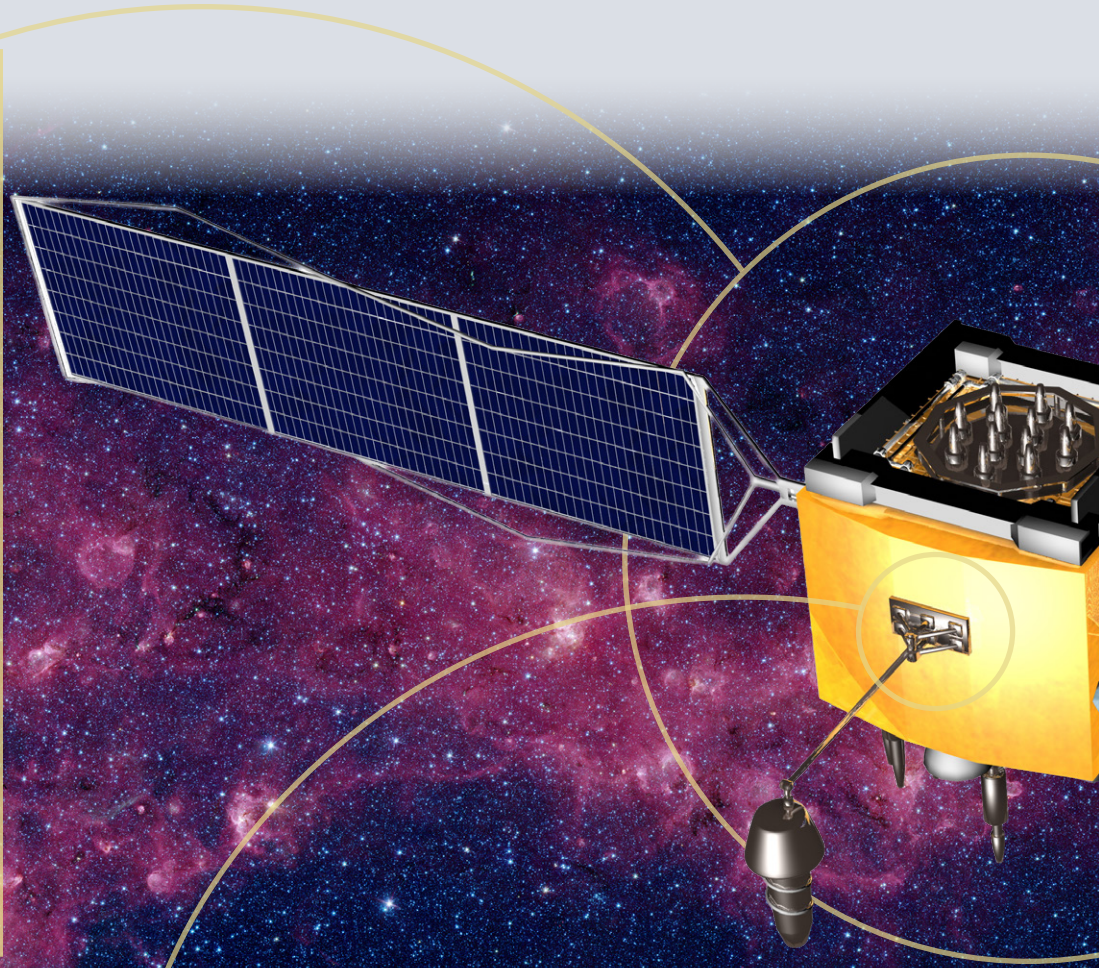

TVAC testing in a USAF environmental test chamber. Glass-sealed hermetic feedthrus maintain enclosure integrity.

ENCLOSURE PENETRATION ZONES

When power and signal pathways pass from the spacecraft exterior into sealed avionics enclosures, pressure boundaries, or contamination-controlled volumes, design requirements change significantly. This transition region—the Enclosure Penetration Zone—relies on ruggedized interconnects that preserve the environmental integrity of the enclosure. Prior to launch, satellites must withstand humidity, coastal salt air, fueling operations, and repeated handling during integration and testing. Hermetic connectors maintain controlled internal atmospheres by preventing moisture ingress and preserving insulation resistance within sealed compartments. During launch, these interconnects must tolerate rapid depressurization, vibration, acoustic loading, and thermal gradients while preventing contamination migration once in orbit.

INTERNAL AVIONICS ZONES

Inside flight computers, avionics boxes, and payload electronics—the Internal Avionics Zone—the environment is far more controlled than on the spacecraft exterior. Here, interconnect selection is driven primarily by package density, weight reduction, and signal integrity. Modern spacecraft avionics rely on lightweight, high-density micro- and nano-miniature PCB connectors. Flex and rigid-flex jumper assemblies route signals between boards. Although protected from the external environment, connectors and assemblies in this zone must tolerate launch vibration while maintaining reliable electrical contact and minimizing fretting or mating wear.



EMI/EMC testing of the NOAA GOES-U satellite

GROUND TEST AND INTEGRATION SYSTEMS

Satellite ground testing represents a distinct category of interconnect architecture. Prior to launch, spacecraft are connected to Electrical Ground Support Equipment (EGSE) used to simulate spacecraft operation, monitor subsystem health, and validate command and telemetry pathways. Ground test harnesses rely on connectors designed for repeated mating cycles rather than extreme environmental performance. D-subminiature, Micro-D, and D38999 connectors are commonly used. High-power ground support equipment may employ ruggedized power connectors such as PowerTrip™. Sealed hermetic feedthroughs also maintain avionics enclosure integrity during Thermal Vacuum Testing (TVAC), where spacecraft are exposed to simulated space conditions inside environmental chambers.

DEPLOYMENT AND SEPARATION INTERFACES

A highly specialized region of spacecraft interconnect architecture involves deployment and separation systems. These mechanisms support critical mission events such as satellite release, solar array deployment, antenna extension, instrument boom deployment, and protective cover release. Because these operations occur only once and are essential to mission success, their interconnect systems must perform with absolute reliability. Technologies used in this zone include blind-mate connectors, assisted-separation force connectors, dead-face connectors, and lanyard-release designs that disengage automatically during deployment. These connector interfaces are often integrated with Hold-Down and Release Mechanisms (HDRMs) that secure deployable structures during launch and trigger release once the spacecraft reaches orbit. Design priorities focus on dependable preload stowage during launch and reliable mechanical release through precisely controlled electrical actuation.



Glenair HDRMs are high-reliability, non-explosive devices for dependable preload stowage and release of deployable space systems with TRL9 flight heritage.



CONNECTING THE SATELLITE BUS TO THE MISSION PAYLOAD

GLENAIR SIGNATURE SPACE-GRADE WIRE AND CABLE BACKBONES

MIL-STARTM
HIGH-PERFORMANCE HOOKUP WIRE AND CABLE

SpeedLineTM
Controlled-Impedance Cables

CROSSLINKED (XL) ETFE HOOKUP WIRE

GS22759-53 / -54

- Low-fluoride. High-strength or standard silver-coated copper core, dual wall modified XL-ETFE insulation/jacket.

Primary Insulation - Extruded, Modified XL-ETFE

Silver-coated copper conductor, standard (-54) or high-strength (-53)

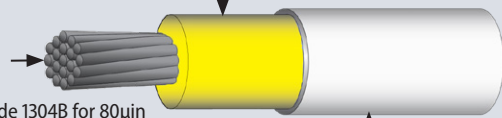

Jacket - Extruded, Modified XL-ETFE

Order with Mod Code 1304B for 80µin silver plating for red plague mitigation in space applications

GS22759-51 / -52

- Low-fluoride. High-strength or standard silver-coated copper core, lightweight / modified XL-ETFE insulation.

Insulation - Extruded, Modified XL-ETFE

Silver-coated copper conductor, standard (-52) or high-strength (-51)

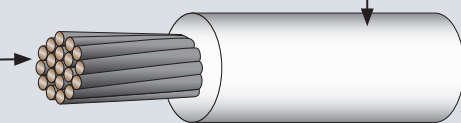

Order with Mod Code 1304B for 80µin silver plating for red plague mitigation in space applications

MULTICONDUCTOR M27500 TYPE CABLES

968-001

- 27500 type with ArmorLite or AmberStrand lightweight microfilament braided shielding

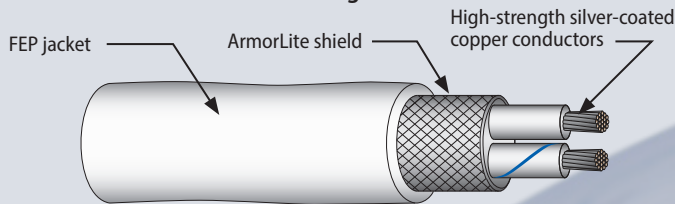

GS27500

- 27500 type with GS22759-33 wire (silver-plated high-strength copper wire, XL-ETFE insulation), and silver-coated copper shielding.

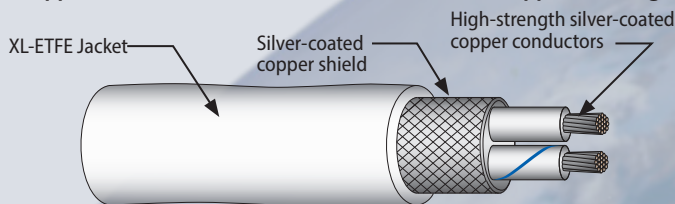

963-066 -24, -26, and -28

100 OHM TWISTED PAIR SHIELDED CABLE FOR EL OCHITO® WHITE / SPEEDMASTER CONNECTORS

- Performance up to 2 GHz
- 65°C to +200°C
- FEP jacket, FEP insulation
- Dual shields: aluminized polyimide tape and metallic braid

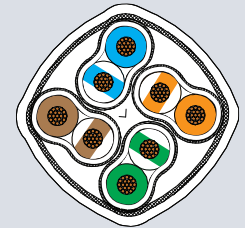

963-069-26

100 OHM #26 AWG FLAT PAIR SHIELDED CABLE FOR USE WITH VERSALINK™ CONNECTORS

- Performance up to 18 GHz
- 65°C to +200°C
- FEP jacket, FEP insulation
- Dual shields: aluminized polyimide tape and silver-plated copper braid

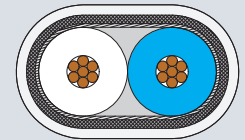

963-057-28

100 OHM TWISTED PAIR SHIELDED CABLE FOR USE WITH MICRO-D HIGH-SPEED CONNECTORS

- Performance up to 10 GHz
- 65°C to +200°C
- FEP jacket, FEP insulation
- Shield: aluminized polyimide tape

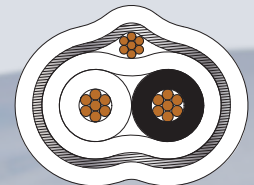

963-065-30

100 OHM #30 AWG TWISTED PAIR SHIELDED CABLE FOR USE WITH GMMD CONNECTORS

- Performance up to 18 GHz
- 65°C to +200°C
- FEP jacket, FEP insulation
- Dual shields: 2X silver-plated copper flat wire and braid

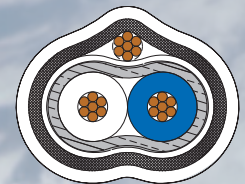

SPACE FLIGHT HERITAGE · HIGH-AVAILABILITY · NO MOQs · FULLY-TESTED

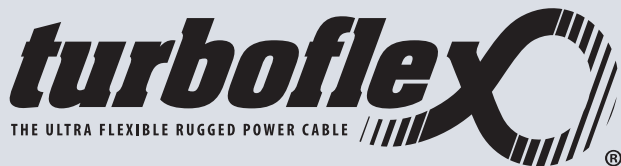

961-033

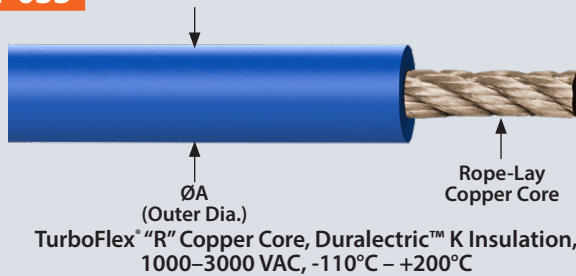

962-032-300



- 50 ohm size .300" diameter, 26.5 GHz max. frequency low-attenuation cable
- -55°C to +200°C rated operating temperature
- FEP jacket, expanded PTFE dielectric, solid SPC center conductor
- Triple-shielded: Tape/foil/braid shield layers with >90 dB shield effectiveness

967-600

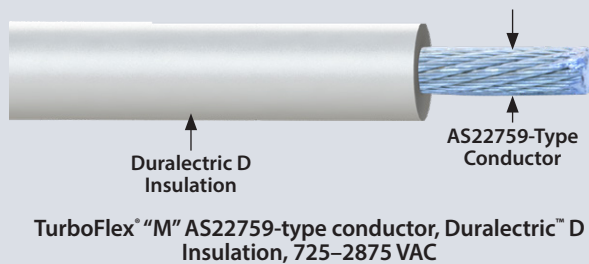

962-032-160

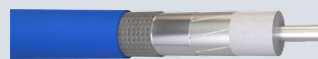

- 50 ohm size .160" diameter, 40 GHz max. frequency low-attenuation cable
- -55°C to +200°C rated operating temperature
- FEP jacket, expanded PTFE dielectric, solid SPC center conductor
- Triple-shielded: Tape/foil/braid shield layers with >90 dB shield effectiveness

961-044

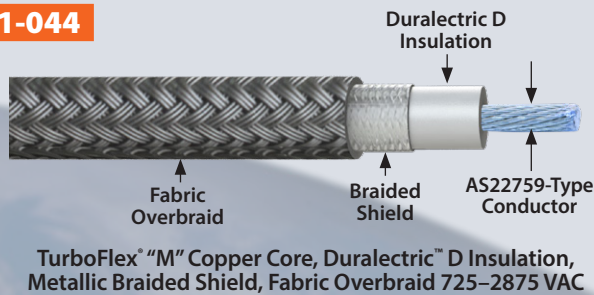

962-025-086



- 50 ohm size .086" (.104" OD), 40 GHz max. frequency low-attenuation cable
- -65°C to +165°C rated operating temperature
- FEP jacket, PFA dielectric, solid SPC center conductor
- Triple-shielded: Tape/foil/braid shield layers with >90 dB shield effectiveness

961-007

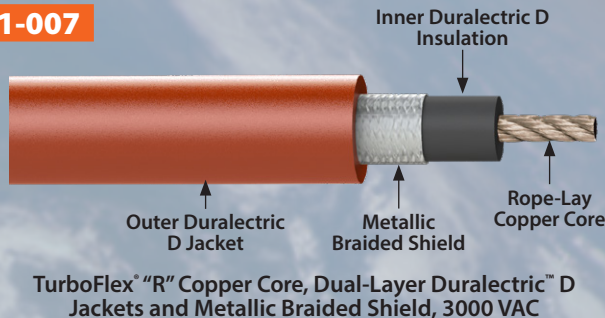

962-025-047



- 50 ohm size .047" (.056" OD), 70 GHz max. frequency low-attenuation cable
- -65°C to +165°C rated operating temperature
- FEP jacket, PFA dielectric, solid SPC center conductor
- Triple-shielded: Tape/foil/braid shield layers with >90 dB shield effectiveness



CONNECTING THE SATELLITE BUS TO THE MISSION PAYLOAD

SuperNine® “BETTER-THAN-QPL” MIL-DTL-38999

SuperNine® is a “Better-than-QPL” MIL-DTL-38999 series connector with board, I/O, cable-to-cable, and system interconnect interfaces. Ideal for satellite bus and payload interconnection architectures that demand mil-spec and/or legacy space-grade pedigree and performance. Triple-start stub ACME and bayonet-lock mating versions offer launch-grade resistance to vibration and shock. Supplied in rugged environmental, class H hermetic, EMI/RFI filter, and connector saver designs.

LEVELS OF INTERCONNECTION

PCB SIGNAL/HIGH-SPEED AND POWER LEAD INTERFACES TO I/O, BUS BAR, OR TERMINALS

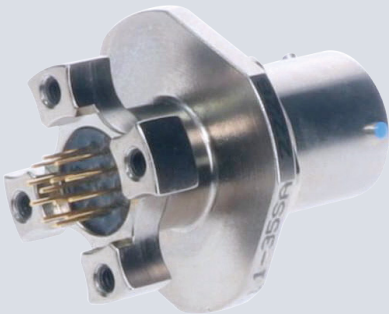

Signal line PCB-to-I/O configurations (dual-standoff bayonet version shown) high vibration and shock-resistant

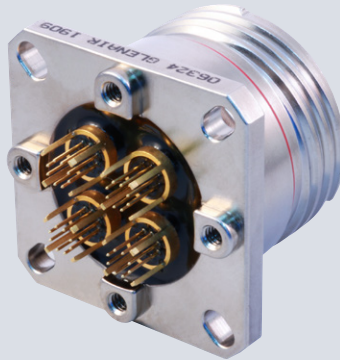

High-speed shielded-contact PCB-to-I/O configuration with solder-flow standoffs (triple-start version shown)

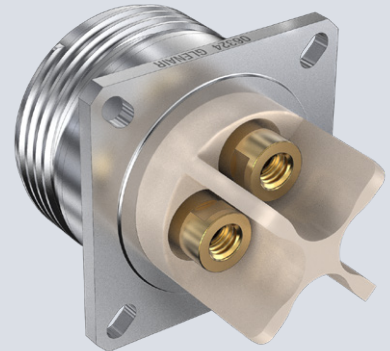

High-amperage Crown Ring contact—SuperNine PowerPlay with threaded post-to-bus bar terminations

GLENAIR SUPERFLEX™ FLEX CIRCUIT I/O-TO-BOARD AND BOARD-TO-BOARD INTERFACES



SuperNine-to-AlphaLink spring-pin contact SuperFlex PCB jumper

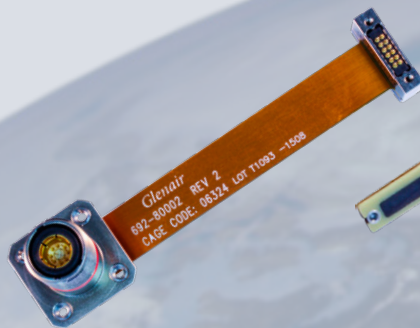

High-speed SuperNine-to-AlphaLink spring-pin contact SuperFlex PCB jumper



SuperNine hybrid multibranch flex circuit assembly

PAYLOAD AND SATELLITE EQUIPMENT I/O INTERFACES: BOX- AND PANEL-MOUNT CONFIGURATIONS

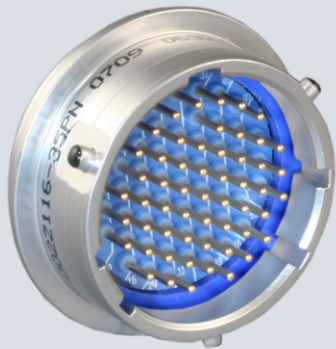

SuperNine Series I bayonet-lock with signal contact pin field for command and telemetry circuits, weld-mount



SuperNine Series I bayonet-lock with hybrid high-speed / signal I/O interface, jam-nut mount

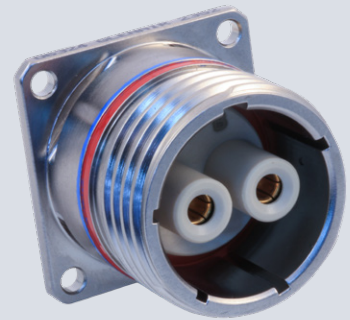

SuperNine PowerPlay with safe-touch high-power distribution contacts, box-mount

CABLE-TO-I/O AND CABLE-TO-CABLE LEVEL CONFIGURATIONS



SuperNine Series III cable plug with integrated shield termination banding porch



SuperNine Series III connector saver for protection of deliverable connectors during qualification testing



SuperNine Series III in-line cable receptacle for cable-to-cable applications

SPECIAL-CLASS CONNECTORS: HERMETICS

SUPERNINE D38999 CLASS H SPACE-GRADE HERMETIC SOLUTIONS

Resolve gas, moisture, and particle ingress problems during launch with NASA-certified glass-sealed hermetic or lightweight, low-resistance CODE RED encapsulant-sealed hermetic designs

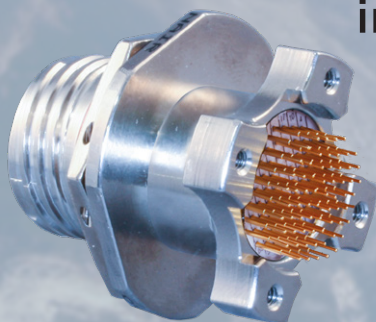

ALL SOLUTIONS DELIVER

- Higher resistance to extreme operating temperatures from -195°C to +260°C
- Superior mechanical strength
- No material breakdown or aging over time
- Helium leak rate <math><1 \times 10^{-7}</math> cc/sec to 1×10^{-10}
- Suitable for use in both flight and ESGE testing



CONNECTING THE SATELLITE BUS TO THE MISSION PAYLOAD



MICRO-MINIATURE
CIRCULAR CONNECTORS

Series 806 Mil-Aero offers significant size and weight savings compared to MIL-DTL-38999 Series I and III while meeting all key performance benchmarks of the standard. Series 806 is ideally suited for satellite bus and payload interconnection for missions that depend on both outstanding environmental performance and reduced size and weight. Interconnect interfaces are available for low-speed control and telemetry signaling, high-speed Ethernet, and power in both Bayonet and Triple-Start Stub ACME mating configurations.

CONTROL, SIGNAL, AND HIGH-SPEED ETHERNET PCB AND FLEX SOLUTIONS

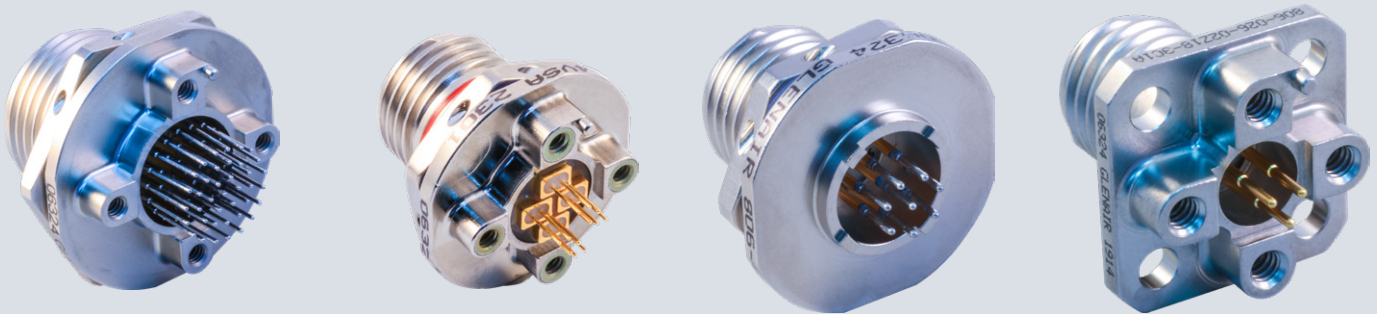

Standard signal and high-speed PCB connectors with various standoff geometries for optimized assembly and resistance to vibration and shock

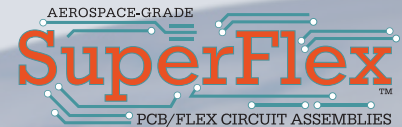
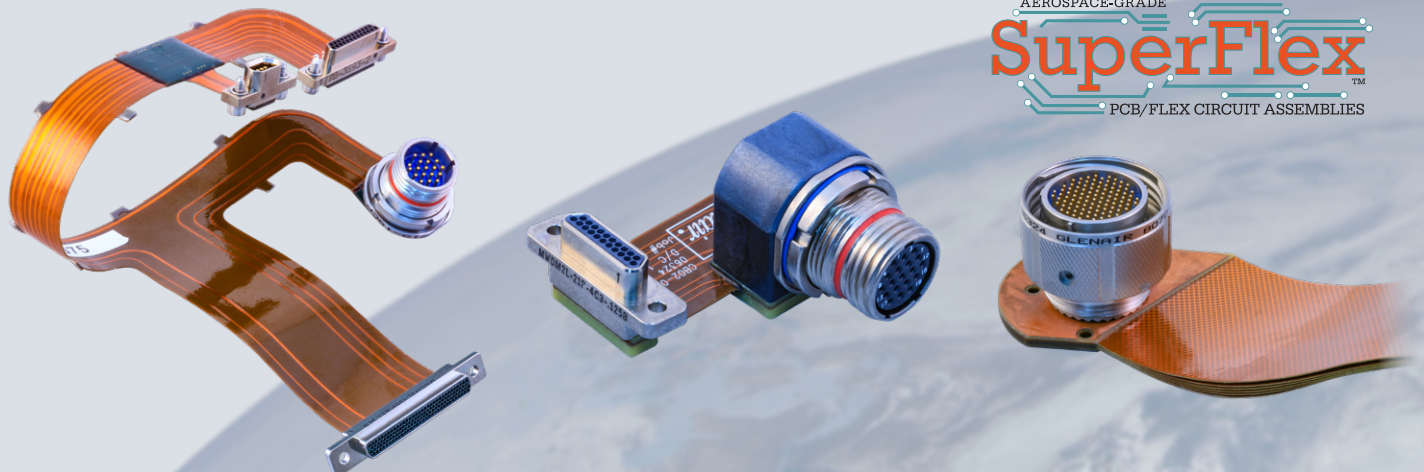

SuperFlex I/O-to-flex and rigid flex reduce size and weight and ensure reliable, repeatable assembly of both payload and core satellite electronic equipment

SUPPORTED SIGNAL, DATA, AND POWER INTERFACES: I/O AND CABLE-TO-CABLE

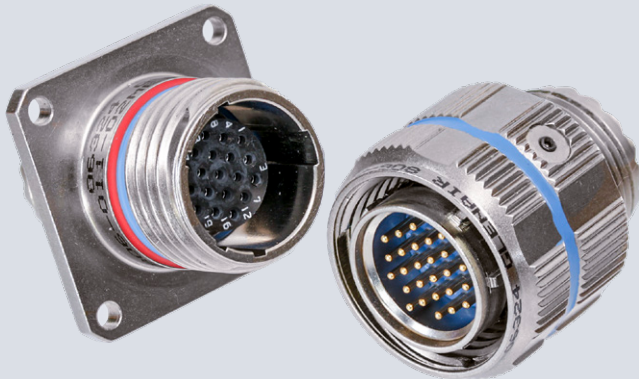

Series 806 Mil-Aero environmental series with micro miniature #20HD contact layouts



Hybrid Series 806 connectors with VersaLink high-speed Ethernet and standard signal arrangements



Series 806 Mil-Aero micro miniature circular with hybrid high-speed EI Ochito octaxial contacts and standard 39029 signal contacts

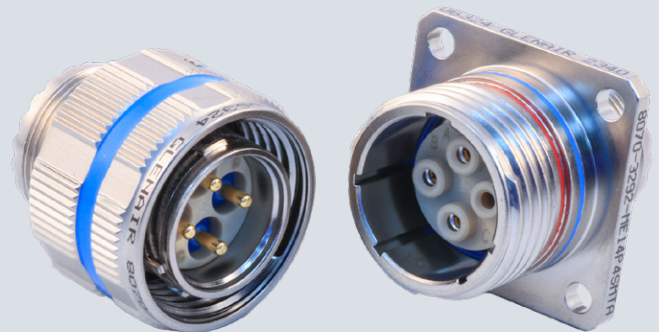

Series 806 Mil-Aero micro miniature with PowerPlay Crown Ring contact arrangements for satellite payload power distribution

SERIES 806 MIL-AERO: FEATURES / SPECIFICATIONS

- Next-generation small form factor aerospace-grade circular connector
- Designed for harsh application and high-altitude environments
- Robust and reliable anti-decoupling technology
- High density 20HD, 22HD, RF, and high-speed contact arrangements
- Lightweight hermetic and filter versions
- +200°C temperature rating
- Improved ramp angle on mating interface for better vibration and shock resistance High-density #20HD and #22HD arrangements for reduced size and weight
- Supported wire sizes:
#20HD contacts 20–24 AWG
#22HD contacts 22–28AWG
- Dielectric withstanding voltage
#20HD layouts: 1800 VAC
#22HD layouts: 1300 VAC
- Reduced pitch triple-start modified anti-decoupling stub ACME mating threads
- +200°C operating temperature
- “Triple ripple” wire sealing grommet (75,000 ft. rated)
- Snap in, rear release crimp contacts
- Metal contact retention clips
- Integral Nano-Band shield termination platform
- EMI shielding effectiveness per D38999M para. 4.5.28 (65 dB min. leakage attenuation @ 10GHz)
- MIL-S-901 Grade A high impact shock



CONNECTING THE SATELLITE BUS TO THE MISSION PAYLOAD



MODULAR HIGH-SPEED MICRO-D CONNECTORS

GMMD is an innovative modular Micro-D connector for high-speed differential twinax applications, standard signal, power, and RF coax—making it the most versatile Micro-D rectangular in the industry. GMMD leverages Glenair Signature Micro and Nano TwistPin contact inserts, as well as ultra small form-factor differential twinax modules delivering 18 Gb/second per pair and RF to 20 GHz. GMMD is supplied as factory-terminated pigtailed, point-to-point jumpers, and surface-mount receptacles for easy PCB termination. GMMD is Glenair’s highest-performing high-speed I/O-to-board solution.

BOARD AND I/O-TO-BOARD INTERFACES

MODULAR SUPPORT FOR SIGNAL, HIGH-SPEED ETHERNET, RF, AND POWER

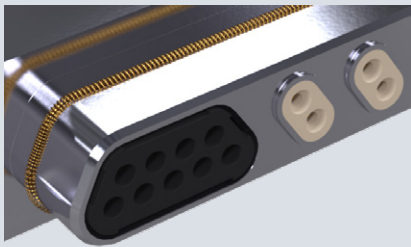

Glenair Signature GMMD contact modules (right) are fully shielded for outstanding cross-talk isolation and signal integrity. Standard Micro-D TwistPin contact modules deliver reliable signal performance IAW MIL-DTL-83513. Insert arrangements with power and RF are also available.

- Low crosstalk, high bandwidth twinax modules for 18Gb/s per pair and RF up to 20GHz
- Cable and 90° PCB configurations for matched 100 Ohm differential impedance performance from I/O to board
- SMT receptacles for easy PCB mounting
- Combo layouts include twinax, 50 and 75Ω coax, mixed signal and power
- TwistPin contacts for low resistance and high shock and vibe performance
- Standard Micro-D shell sizes and hardware

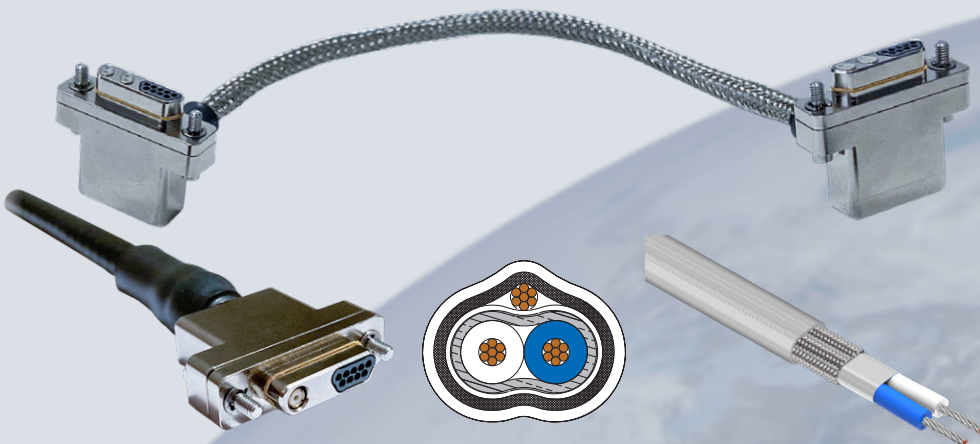

Twinax and hybrid twinax jumpers and pigtailed supplied with SpeedLine 100 Ohm shielded twisted pair cable

GMMD BOARD, I/O, AND PIGTAIL / JUMPER ASSEMBLIES MEET ALL SATELLITE SIGNAL, HIGH-SPEED, POWER, AND RF REQUIREMENTS

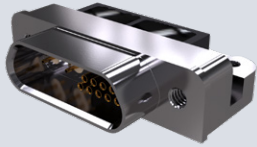

Horizontal PCB-mount twinax and combo twinax receptacles

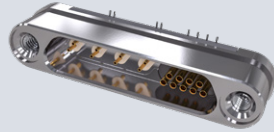

Vertical PCB-mount twinax and combo twinax plug and receptacles



Twinax and combo twinax jumpers and pigtails



Horizontal PCB-mount coax and combo coax receptacles

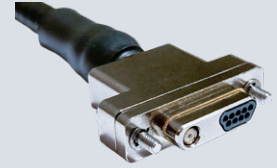

Coax and combo coax jumpers and pigtails

GMMD TWINAX AND COMBO TWINAX CONTACT ARRANGEMENTS (additional arrangements are available, consult factory)						
Contact Arrangement	2T	4T	2T9	2T15	4T9	
Shell Size	9	15	21	25	31	
No. / type of contacts	2 Twinax	4 Twinax	2 Twinax, 9 #24	2 Twinax, 15 #24	4 Twinax, 9#24	
Example applications	SpFi	10GbE, 2xSATA, SpW, 2xSpFi	USB 3.1, SATA + power		HDMI, DP, DVI, 10GbE + power	
Contact Arrangement	5T9	8T	4T15	8T15	4T31	12T
Shell Size	31	31	37	51-2	51-2	51-2
No. / type of contacts	5 Twinax, 9 #24	8 Twinax	4 Twinax, 15 #24	8 Twinax, 15 #24	4 Twinax, 31 #24	12 Twinax
Example applications	DP incl. Aux channels	2x10GbE		DP or HDMI + USB 3.1, dual DVI		
Contact Arrangement	12T15	6T37	8T31	16T		
Shell Size	67	67	67	67		
No. / type of contacts	12 Twinax, 15 #24	6 Twinax, 37 #24	8 Twinax, 31 #24	16 Twinax		
Example applications				4x10GbE		

GMMD COAX AND COMBO COAX CONTACT ARRANGEMENTS (additional arrangements are available, consult factory)				
Contact Arrangement	2C	4C	6C	
Shell Size	9	21	25	
No. / type of contacts	2 X 50Ω Coax	4X 50Ω Coax	6X 50Ω Coax	
Contact Arrangement	8C		16C	
Shell Size	37		67	
No. / type of contacts	8 X 50Ω Coax		16X 50Ω Coax	
Contact Arrangement	2C9	1V9	2V9	4V
Shell Size	21	21	31	21
No. / type of contacts	2X 50Ω Coax, 9 X #24	1 X 75Ω Coax, 9 X #24	2 X 75Ω Coax, 9 X #24	4 X 75Ω Coax



CONNECTING THE SATELLITE BUS TO THE MISSION PAYLOAD



THE SMALLEST, LIGHTEST HIGH-SPEED MICRO-D

The High-Speed Micro-D (GHSM) uses an impedance optimized open pin field for high-density signal routing flexibility. 1 Amp pre-wired cable and PCB solutions deliver up to 15 Gbps performance per differential pair. Auxiliary EMC ground springs on plugs ensure data integrity and low attenuation performance. Ideally suited for satellite bus and payload applications that demand the absolute smallest and lightest high-speed solution in a mil-spec grade rectangular package.

BOARD-MOUNT, I/O-TO-BOARD, AND SYSTEM-TO-SYSTEM CABLE ASSEMBLIES

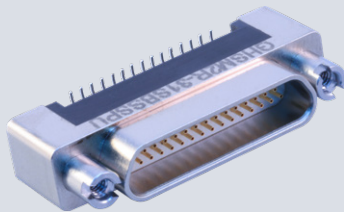

Straight Surface-Mount PCB, Jackpost Hardware

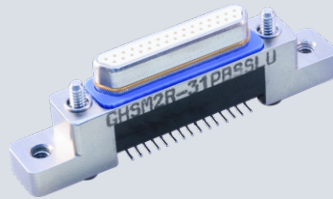

Straight Surface-Mount PCB, Jackscrew Hardware

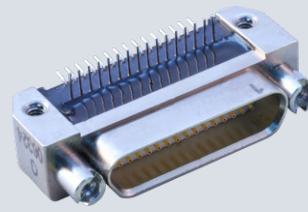

Hybrid Right-Angle PCB, Jackpost Hardware

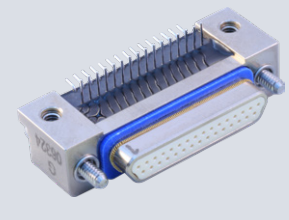

Hybrid Right-Angle PCB, Jackscrew Hardware

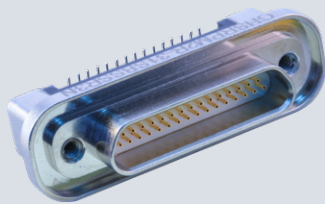

Straight Surface-Mount Rear Panel-Mount

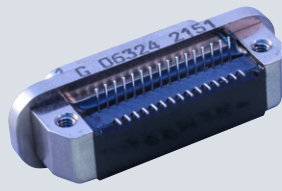

Hybrid Right-Angle Rear Panel-Mount

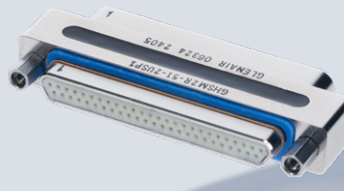

Connector savers for ground test applications

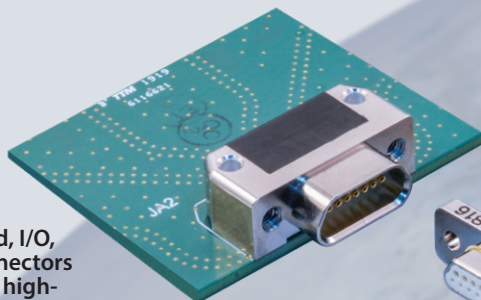



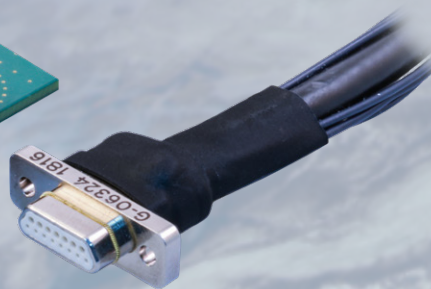





Versatile board, I/O, and cable connectors for all satellite high-speed and signal requirements



- Unique contact isolation and spacing for optimal high-speed performance up to 15 Gbps
- Supports maximum #28 AWG wire
- Low-κ dielectric insulator combined with optimized contact size and spacing
- Precision-machined shells with gold or nickel plating
- 1 Amp TwistPin contacts for optimal performance in harsh vibration, shock, and high-temperature environments

SUPPORTED HIGH-SPEED PROTOCOLS

High-Speed Micro-D connectors and cables are optimized for multi-gigabit digital datalink protocols including USB 3.0, 10Gb Ethernet, Camera Link, and PCIe 3.0. The mil-spec-grade connector series features machined-shell packaging, low-attenuation contact spacing, low-κ PPS dielectric insulators, and Glenair shock- and vibrate-resistant Nano TwistPin contacts.

 21 Display Port 1.2	 21 HDMI 2.0	 25 DVI-D Dual	 21 DVI-D Single
 15 SATA Gen 1, 2, and 3	 15 USB 3.0 SuperSpeed	 15 Up to: Cat 6A (10GBASE-T Ethernet)	 31 Camera Link

HIGH-SPEED PIGTAIL AND BACK-TO-BACK CABLE JUMPERS

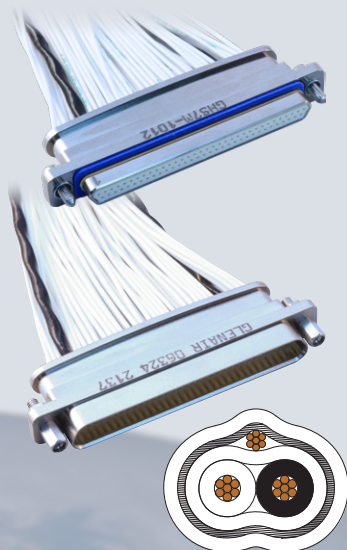

Turnkey, prewired plug and receptacle cable connectors are available as single-ended pigtailed or back-to-back cable assemblies with pin or socket contacts. Shielded twisted pair SpeedLine cable for differential data pairs is supplied in either 100 or 90 Ohms with a selection of jacketing and color. Discrete hookup wires may be specified in #28 or #30 gauge. Variable lengths of the assembly may be specified in 1 inch increments.

High-Speed Micro-D contact arrangements face view pin connector

- high-speed signal pair
- signal-pair drain wire
- low-speed signal or power contacts

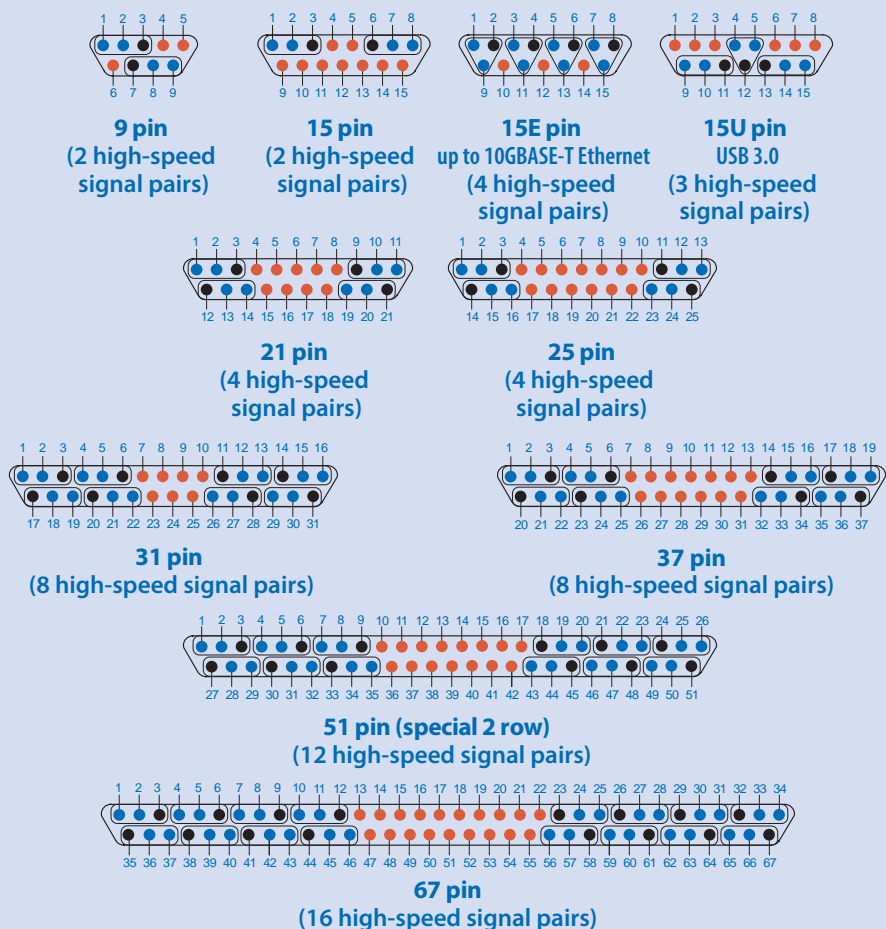

SHIP & WORLD: THE TWELVE MOST MISSION-CRITICAL SPACECRAFT NOVELS OF ALL TIME



1. Project Hail Mary — Andy Weir

A lone astronaut solving existential problems with nothing but onboard systems and ingenuity. Pure systems engineering drama.

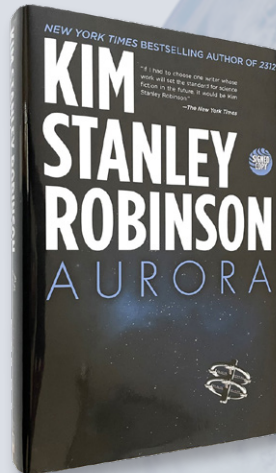

2. Aurora — Kim Stanley Robinson

The definitive modern generation ship novel—closed-loop life support as both setting and central conflict.



4. Children of Time — Adrian Tchaikovsky

A failing ark ship carrying the remnants of humanity—systems decay mirrored by social collapse.



3. Blindsight — Peter Watts

Hard, clinical first-contact aboard a specialized research vessel. Sensors, interfaces, and cognition all under scrutiny.

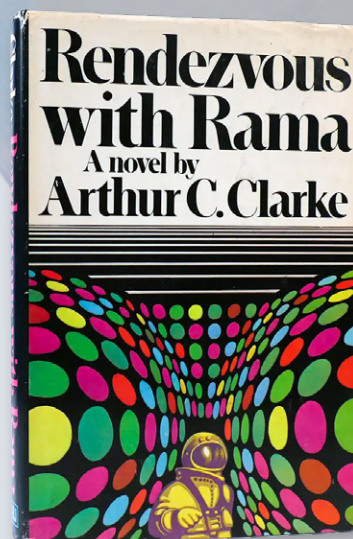

5. Rendezvous with Rama — Arthur C. Clarke

Exploring an alien craft that is itself a world. The ultimate “unknown interface” story.

6. Six Wakes — Mur Lafferty

A colony ship where the crew are repeatedly cloned—until something breaks. A closed system with no outside help.

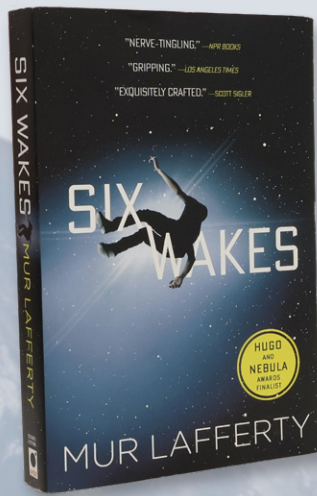

7. Seveneves — Neal Stephenson

When the moon shatters, the ISS becomes the “Cloud Ark,” a desperate cobbled-together life raft for humanity.

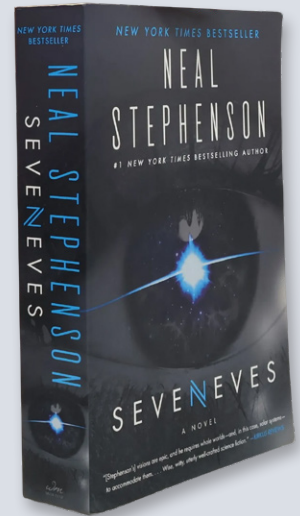

8. Hull Zero Three — Greg Bear

A vast ship gone feral. Mission unknown, systems fragmented, environment hostile.

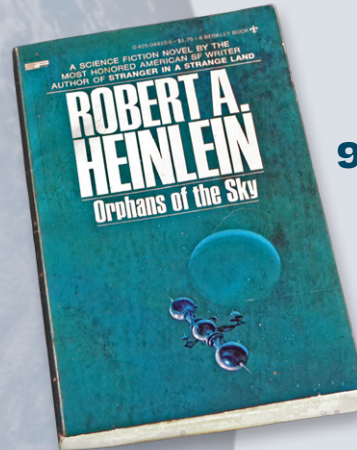

9. Orphans of the Sky — Robert A. Heinlein

The original “lost the manual” scenario—crew no longer knows they’re on a ship. Still hits hard.

10. The Long Way to a Small, Angry Planet — Becky Chambers

A warmer entry, but still a fully realized shipboard world—culture, relationships, and work all bounded by the vessel

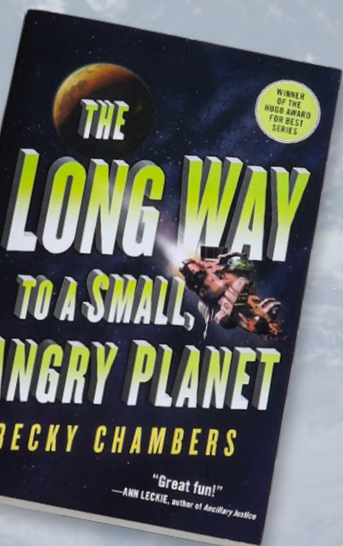

11. The Freeze-Frame Revolution — Peter Watts

Crew cycling through time aboard an AI-run mission. Control, autonomy, and system authority taken to extremes.

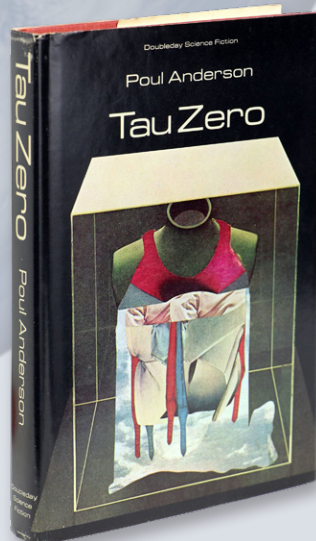
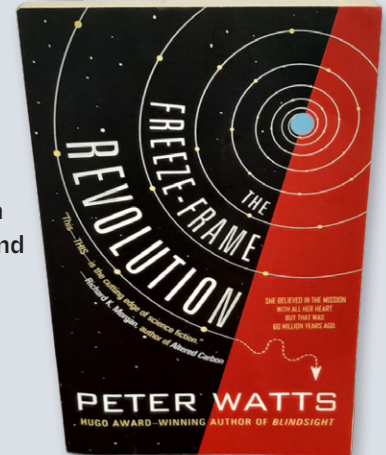

12. Tau Zero — Paul Anderson

The ultimate engine failure nightmare. After a collision damages the deceleration system, the Leonora Christine is forced to accelerate indefinitely.



CONNECTING THE SATELLITE BUS TO THE MISSION PAYLOAD

PowerPlay™ HIGH-POWER CONNECTORS AND CABLES

PowerPlay is a high-power, single-pole and multi-pole connector series—with four different circular and rectangular packaging options: SuperNine Series III triple-start, SuperNine Series I bayonet, Series 806 micro-miniature, and Micro-Crimp precision rectangular. The connector series combines Glenair signature raised tower insert architecture, Crown Ring contacts, and TurboFlex cable compatibility into the interconnect industry’s most innovative power solution. Ideal for interconnection of satellite bus power supply, battery modules, and power regulation and conversion equipment.

PLUG-TO-PLUG AND I/O CONFIGURATIONS WITH SAFE-TOUCH ARCHITECTURE AND A RANGE OF BACK-END WIRE LINE TERMINATIONS

PowerPlay’s high-conductivity Crown Ring contact and dielectric insert technology delivers 5,000 VAC dielectric withstanding voltage. Raised safe-touch socket tower and available safe-touch pin meets industry protection requirements for high power distribution applications. PowerPlay connectors employ high-performance, high-temperature materials throughout. This means that the interconnect system can withstand higher temperature rise than the typical Mil-Aero connector.

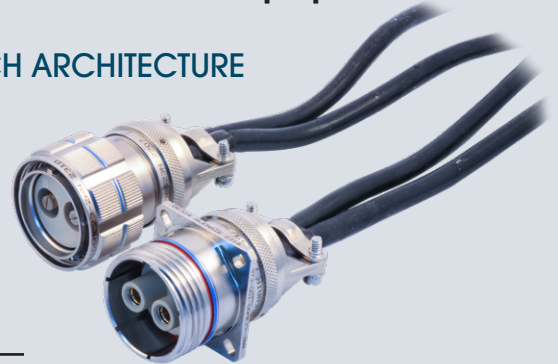

ABOUT TURBOFLEX “M” AND TURBOFLEX “R” CABLE CONSTRUCTION

TurboFlex cables are jacketed with Duraelectric insulation, which contributes to the flexibility of the product. TurboFlex R (rope-lay core) provides maximum flexibility. TurboFlex M (M22759 core) has a slightly larger bend radius but far superior flexibility compared to standard M22759 cable. Both configurations are supplied in gauges optimized for use with PowerPlay.



TurboFlex R with rope-lay cable construction



TurboFlex M with M22759 cable construction

- 5000 VAC dielectric withstanding voltage
- High current, low-resistance, and superior vibration performance
- Safe-touch finger-proofing
- Integrated band platform cable shield termination
- Compatible with TurboFlex high-flexibility cable
- Support for bus-bar and other wire terminations
- Multi-pin arrangements for size 8 and 4 AWG contacts. Single-pole arrangements for 2, 1/0, 2/0, and 4/0 contacts. Options for 20 AWG interlock contacts on all sizes

KV SEAL 13.5 KVDC–22 KVDC HIGH-VOLTAGE, LOW AMPERAGE CONTACT ASSEMBLIES FOR DC SATELLITE PROPULSION



Drop-in solutions for satellite propulsion, traveling wave tube amplifier, and altimeters. Available in SuperNine PowerPlay, Mighty Mouse, and Series 79 rectangular packaging

POWERPLAY CONNECTOR PACKAGING

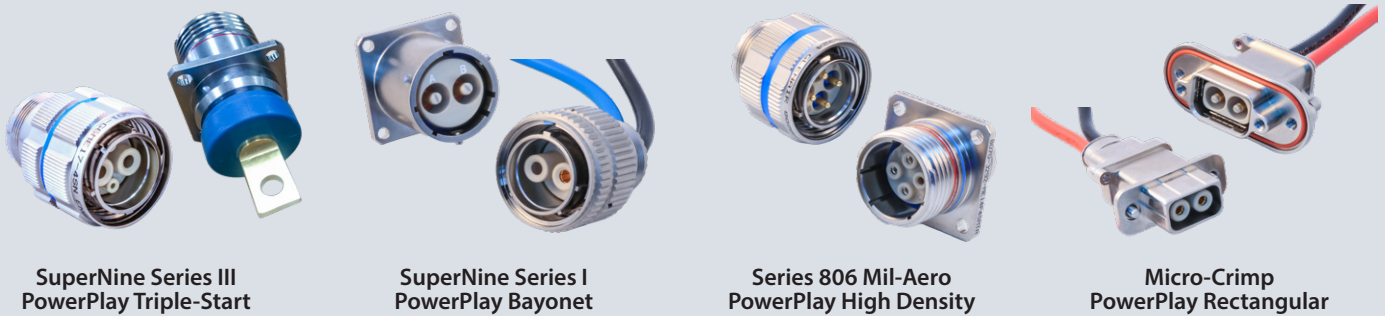

PowerPlay™: KEY CONNECTOR AND CONTACT DESIGN FEATURES, PLUG/RECEPTACLE CUTAWAY VIEWS

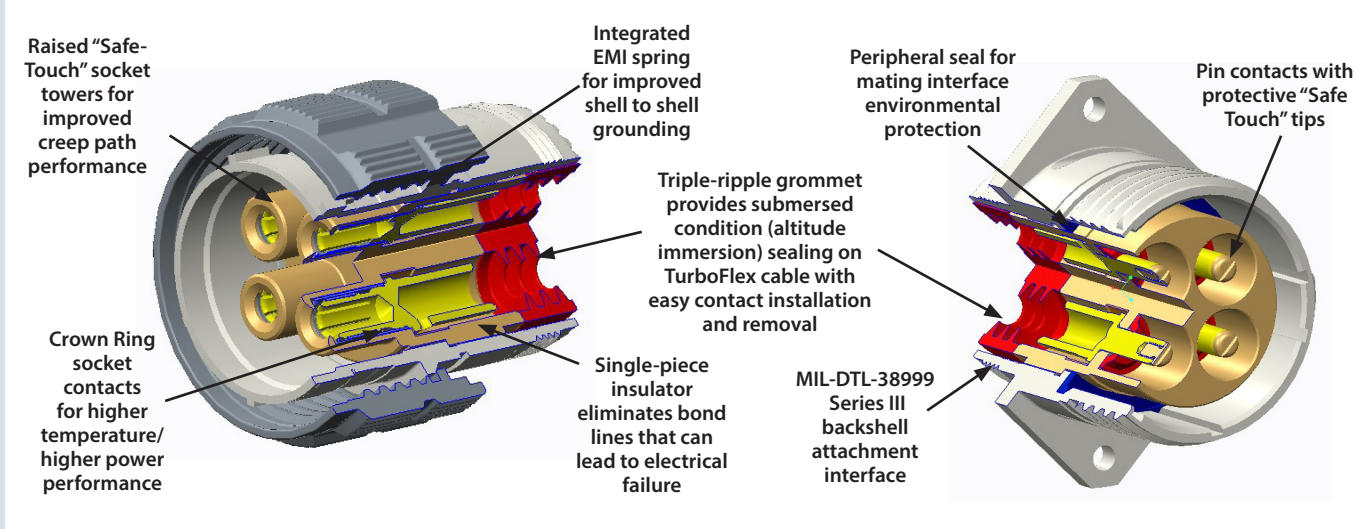

GLENAIR SIGNATURE CROWN RING CONTACTS

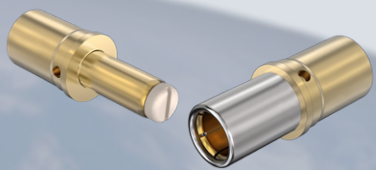

- High vibration-resistant, high-conductivity gold-plated copper alloy. Socket contact adds stainless steel Crown Ring; pin contact adds thermoplastic finger-safe tip
- Up to 60% lower contact resistance than equivalent AS39029 contacts
- High operating temperature resistance compared to other specialized high-power contacts

TURBOFLEX® ULTRA FLEXIBLE / RUGGED POWER CABLES WITH DURALECTRIC JACKETING

TurboFlex high-flexibility power cabling is optimized for use with PowerPlay connectors and is supplied with Glenair signature Duralectric jacketing material for rugged fluid immersion, caustic chemical exposure, temperature extremes, and UV radiation. Duralectric is available in a broad range of colors including safety orange. Two cable core constructions are supplied: TurboFlex M with AS22759-type conductors, and TurboFlex R with ultra-flexible rope-lay conductors.



Available with cable gauge selections from 8 AWG to 4/0, to provide suitable margins for DWV, frequency derating, and peak-load electrical performance.

DURALECTRIC JACKETING	
Abrasion Resistance	Good
Wear Resistance	Good
Flame Resistance	Excellent
Sunlight Resistance	Excellent
Flex Resistance	Excellent



CONNECTING THE SATELLITE BUS TO THE MISSION PAYLOAD

PowerPlay™ HIGH-POWER CONNECTORS AND CABLES

CROWN RING CONTACTS MAXIMIZE CURRENT CARRYING CAPACITY

Current carrying capacity can be defined as the maximum level of current that a connector can handle, while keeping all the components of the connector at or below their temperature limits. Temperature rise is caused by the heat generated from current flowing against the resistance of the conductive path. The two main sources of resistance in a cable system are the bulk resistance of the wire and the contact junction within a pair of connectors.

CROWN RING CONTACTS MINIMIZE CONTACT RESISTANCE

To keep temperature rise to a minimum, Glenair developed its signature Crown Ring contacts for use in PowerPlay connectors. Crown Ring contacts are designed to minimize contact resistance by using high conductivity copper alloy and a stainless steel ring for contact normal force. The results are contact resistance values 75% less than AS39029 required limits and as much as 60% less than average M39029 contact performance (see graphs here). Crown Ring contacts, with extremely low contact resistance, also exhibit lower temperature rise when compared to standard M39029 contacts and specialized high-power contacts from other manufacturers.

NOTE: Lower temperature rise reduces heat aging of surrounding insulation, leading to longer life and higher reliability of the connector.

STANDARD CONTACT RESISTANCE (PER AS39029 TABLE 6)

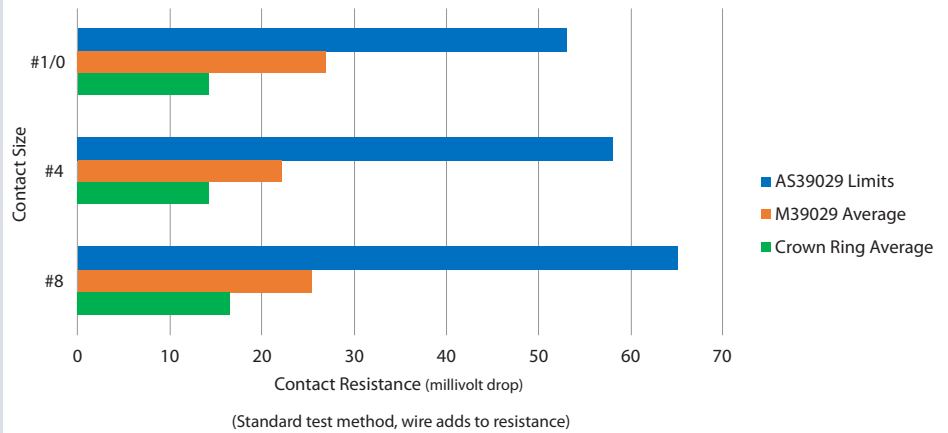

CONTACT RESISTANCE AFTER SUBTRACTING RESISTANCE OF WIRE

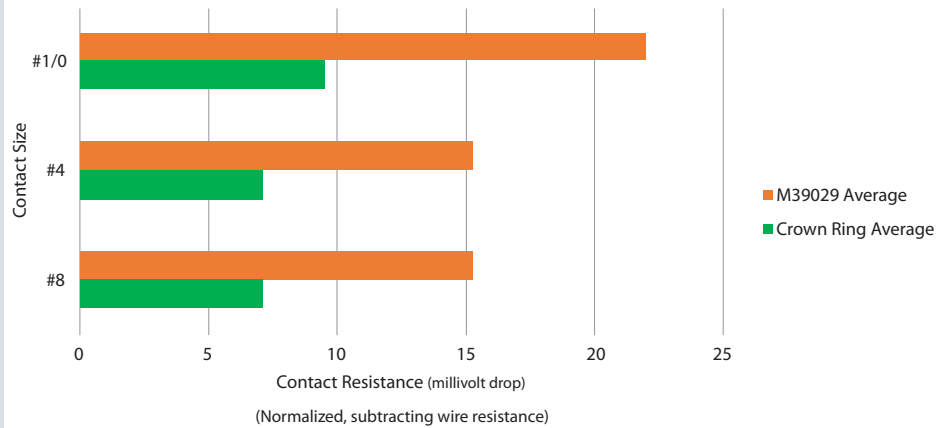

TEMPERATURE RISE

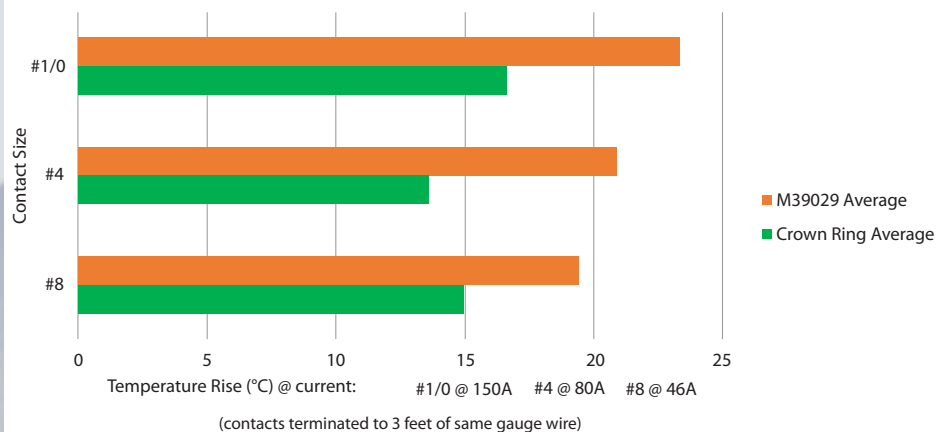



SPACE-GRADE · TRL 9

Release and Separation Interconnect Mechanisms

- **HOLD-DOWN AND RELEASE MECHANISMS (HDRM)**
- **BLIND-MATE / ASF / LANYARD-RELEASE CONNECTORS**

Glenair's line of low-shock **HDRM mechanisms** includes both North American manufactured devices as well as an EU Series in accordance with ESA standards. Glenair offers a complete HDRM solution for satellite equipment deployment including pin pullers and mechanical release ground test units. Our line of **blind-mate, dead-face, ASF, and fail-safe disconnects** are the most extensive in the industry. Glenair's family of release and separation mechanisms is augmented with space-grade **flexible grounding straps, ESD bonds, and corrosion-resistant space-grade wire.**

- Low-shock / pyrotechnic-free for single-event release of deployable space systems—configurable electrical initiation with no (amperage) upper limit
- Blind-mate, adjustable separation, dead-face, and lanyard-release connectors
- High tensile strength shield termination system
- Low-resistance, high-conductivity, flexible ground / ESD bond straps
- Available 80µin silver-plated Red Plague-resistant circuit wire



SPACE-GRADE - TRL 9
Release and Separation Interconnect Mechanisms
• HOLD-DOWN AND RELEASE MECHANISMS (HDRM)
• BLIND-MATE / ASF / LANYARD-RELEASE CONNECTORS

OCTOBER 2025



Non-pyrotechnic Hold Down and Release Mechanisms—US- and EU-made IAW local standards and market requirements

Artist concept of NASA's Juno spacecraft exploring Jupiter
NASA/JPL-Caltech

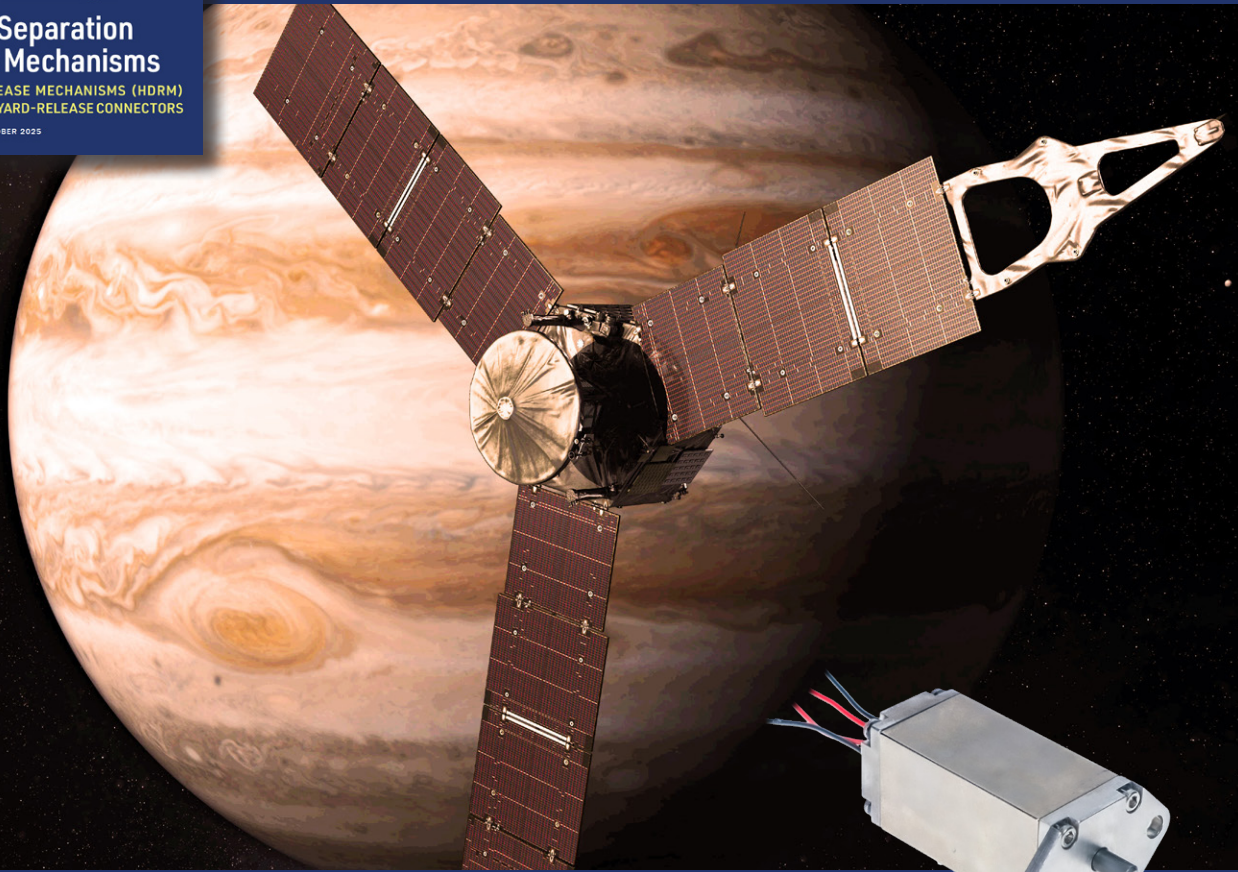

High-reliability, non-explosive (split-spool) HDRMs, separation nuts, and pin pullers/pushers for dependable preload retention and release of deployable space systems

Glenair pyrotechnic-free release mechanisms offer quick release time, low shock, relatively low power input, and virtually no temperature sensitivity. HDRM Series includes separation nuts, pin pullers—direct wired or connectorized—with a broad range of preload carrying capacity. Custom configurations available including pin pushers and other release designs.

- Pyrotechnic-free (low-shock with fuse-wire) for single-event release of deployable space systems—configurable electrical initiation with no (amperage) upper limit
- Single-event device, user-serviceable and refurbishable
- Redundant or non-redundant actuation circuit
- Not susceptible to transient and noise (EMI/EMP/ESD/RFI) inputs
- Extended temperature ranges: -150°C to +150°C



NON-PYROTECHNIC Hold Down and Release Mechanisms



Product Line Overview

HDRM DUTY CLASSES

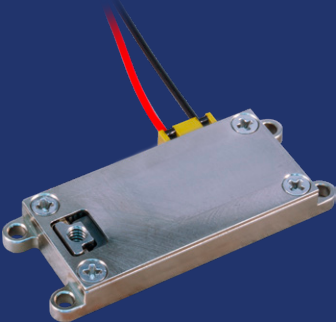

Light-Duty HDRM
Redundant circuit,
5 – 24 lb release preload

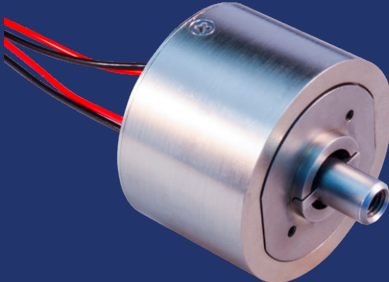

Medium-Duty HDRM
Redundant circuit,
300 – 4000 lb release preload

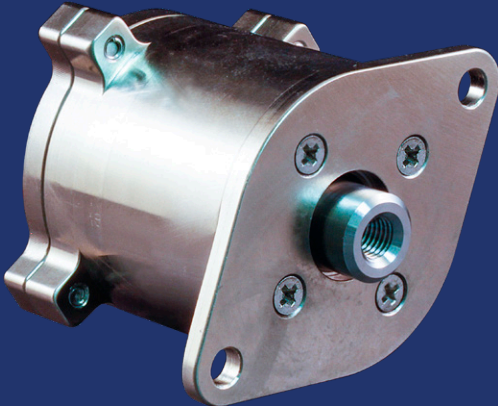

Heavy-Duty HDRM
Redundant circuit,
5000 – 20,000 lb release preload

HDRM RELEASE TYPES

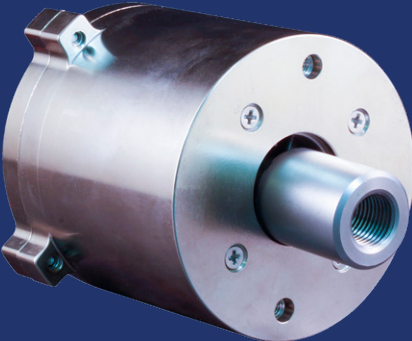

Separation nut



Pin puller



Mechanical release test unit

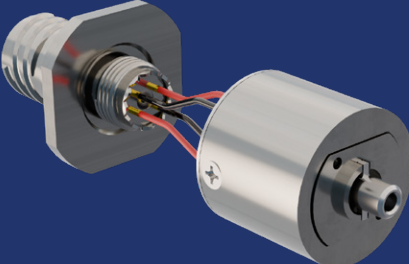

Harnessed

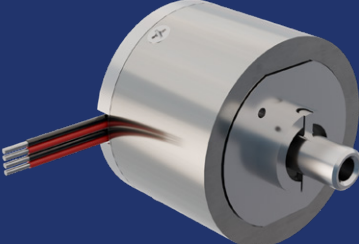

90° Bend

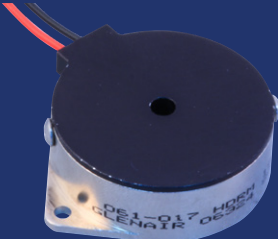

Low-profile



SERIES 06 AND SERIES GSS Hold-Down and Release Mechanisms

Technology Overview

High-reliability, non-explosive (split-spool) separation nuts and electromechanical release mechanisms for dependable preload stowage and release of deployable satellites and space systems

Glenair HDRMs are optimized for foolproof near-simultaneous release reliability with built-in electrical redundancy. The planned release of deployable satellites and structures is activated by a pre-determined electrical current to a fuse-wire system which causes the wire to break under tension and allows a pre-loaded mechanical bolt to actuate. Glenair's line of low-shock, redundant and non-redundant space mechanisms includes both HDRM devices as well as a family of lightweight pin pullers. Customer-defined electrical initiation (with no amperage max limit), as well as custom housing, pin pusher designs, and mounting configurations are available. Consult factory for specific device TR level and qualification test reports.

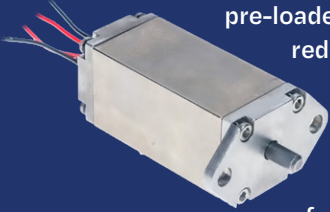

- Single-event, pyrotechnic-free HDRMs for release of deployable space systems
- Configurable electrical initiation with no (amperage) upper limit
- Near-simultaneous release dependent on temperature and power
- User-serviceable and refurbishable units
- EU series IAW ECSS-E-ST-33-01C
- Not susceptible to transient and noise (EMI/EMP/ESD/RFI) inputs
- Extended temperature ranges: -150°C to +150°C

EUROPEAN-MADE HDRM SOLUTIONS IAW ECSS-E-ST-33-01C SPACE MECHANISM STANDARD

Our European-made HDRMs with clean-room assembled actuators are designed for drop-in use in ESA and commercial European standard space applications. Available Mechanical Release test units.



Medium-Duty HDRM
Redundant circuit,
1.5 kN release preload



Medium-Duty HDRM
Redundant circuit,
3 kN release preload



Medium-Duty HDRM
Redundant circuit,
6 kN release preload



Medium-Duty HDRM
Redundant circuit,
11 kN release preload



Medium-Duty HDRM
Redundant circuit,
12 kN release preload



Medium-Duty HDRM
Redundant circuit,
18 kN release preload



Medium-Duty HDRM
Redundant circuit,
24 kN release preload

NORTH AMERICA SERIES 06 AND EU SERIES GSS Hold-Down and Release Mechanisms

Technology Overview

FUSE-WIRE TECHNOLOGY Glenair non-pyrotechnic hold-down and release mechanism technology is based on a fusible wire-actuated separation nut design, increasingly popular for its reliability and low-shock release action. Fuse wire-actuated nut technology has the added benefit of being partially reusable and refurbishable post-deployment.

LEGACY HDRM DEVICES A broad range of hold down release mechanism technologies have been historically used to deploy satellites and appendages (solar arrays, antenna reflectors, radiators, instruments, doors, sensors, booms, and so on) in space. Most of these technologies relied on non-reusable (explosive/pyrotechnic) designs that suffered from a broad range of deficiencies, including susceptibility to electromagnetic interference, problematic synchronization of release with mission requirements, high-shock release action, and significantly, the inability to reuse or refurbish the device during test. Glenair HDRMs solve every one of these problems.

HDRM FUNCTIONALITY The Glenair family of HDRM / pin pullers are non-pyrotechnic release mechanisms with the ability to carry defined tensile preloads until fuse-wire release is initiated with an electrical current applied to the actuation circuit, at which time the restraint wire—wrapped under tension—unwinds, initiating actuation and releasing the associated preload. Any potential energy release during actuation is fully countered by the measured delivery system.

KEY COMPONENTS All three key components of Glenair HDRMs (preloading assembly, release actuator, and load-carrying structure) may be packaged according to specific customer requirements including connectorization in place of wire leads. Electrical initiation current level is also configurable over a wide current range. Packaging options include cylindrical or rectangular housings, lightweight materials, unique shapes and profiles, non-standard mounting dimensions and more.

PERFORMANCE Glenair HDRMs are immune to all forms of EMI or ESD, and capable of easily sustaining significant defined preloads—with release deployment times comparable to conventional explosive actuators. Near-simultaneous release of multiple HDRMs is ± 7 msec with 3.5A supplied as a nominal current (within the same temperature range). Improved simultaneity is achieved with the application of higher-current initiation.

FLIGHT HERITAGE Glenair HDRMs have achieved flight heritage and are now marketed by the company with TRLs of 9. Consult the factory for test reports and TRL qualification levels for specific devices.

DEPLOYMENT APPLICATIONS



Solar Arrays

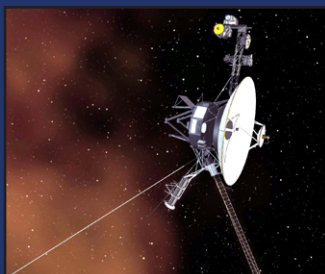

Booms and Masts



Antennas

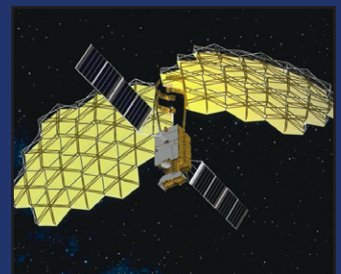

Reflectors

SCALABLE DESIGNS: FROM CUBESATS TO 20,000 POUND PAYLOADS

- Fuse-wire based technology
- Redundant or non-redundant actuation circuit
- Space-rated and screened materials
- Configurable electrical initiation with no (amperage) upper limit



Catalog and custom solutions available, including redundant- and non-redundant HDRMs, power draw resistor-equipped units, and connectorized solutions with space-grade micro miniature Series 806 Mil-Aero connectors.



SERIES 06 AND SERIES GSS Hold-Down and Release Mechanisms

Technology Overview

ATTACHMENT AND PRELOAD OPERATION FOR RELEASE-ROD-EQUIPPED HDRMS

HDRM preload ensures a secure and stable hold during launch and a reliable, predictable release in space. The preload measurement, such as 2500 lbs, represents the maximum force that the HDRM can hold and release at time of deployment. The units can exceed the rated preload during vibration and shock but cannot exceed the rated preload during release. Preload is applied during the installation process after the HDRM has been attached to the main structure using the threaded mounting points on the underside of the device. The physical attachment of the deployable payload to the HDRM is accomplished by affixing a threaded tie rod from the payload directly to the release rod in the HDRM.

GS22759-44 XL-ETFE WIRE

Glenair MIL-STAR GS22759-44 is a space-grade cross-linked ETFE hookup wire with a silver-plated copper alloy core IAW MS22759/44. XL-ETFE is preferred for space use due to this insulator material's ability to mitigate white plague corrosion. Silver plating is preferred for space applications due to its superior conductivity and low resistance. Customers may specify 80 microinch thick silver plating (Mod Code 1450) for additional protection against red plague corrosion.

AXIAL VS. SHEAR PRELOAD ORIENTATION IN HDRM DEVICES

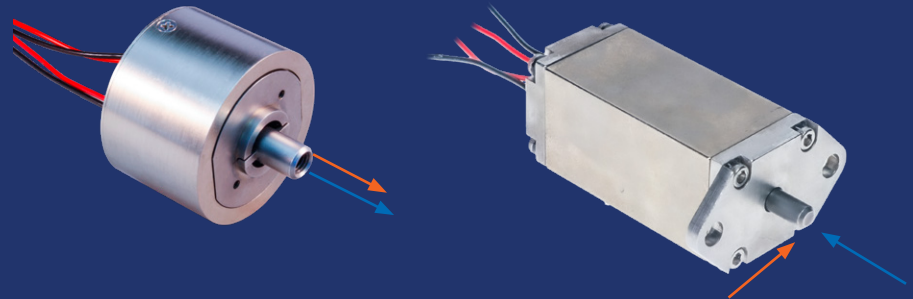

Red arrows indicate the preload or applied force direction into the HDRM device. Blue arrows indicate the direction of motion when the HDRM is actuated (released).

AVAILABLE TECHNICAL DOCUMENTATION

Glenair is able to supply complete documentation for both its North American series 06 and EU series GSS HDRMs where applicable including

- Post ground test refurbishment instructions
- Qualification and acceptance test reports
- FMEA and reliability reports
- 2D dimensional and 3D CAD models

HDRM GROUND TESTING

Glenair HDRMs with fuse wire initiators support two distinct testing configurations for ground validation of system readiness and functionality: mechanical release testing and electrical initiation testing.

Glenair mechanical release test unit HDRMs are used for verification of preload capacity and mechanical disengagement action without consuming or damaging fuse wire or initiator hardware. This test simulates the release function by mechanically triggering the separation mechanism—via the simple turn of a wrench—enabling repeatable tests of the hold-down interface, latch response, and structural integration.

The replaceable initiation kit is designed to support full electrical testing, where the actual fuse wire initiator function is energized and expended as in a live deployment. This process ensures complete end-to-end functionality of the electrical initiation path—including redundant circuit power routing, thermal response, and fuse wire separation—but requires replacement of the consumable initiator components after each test.

Together, these two testing methodologies ensure comprehensive verification of both mechanical and electrical aspects of HDRM performance.



Mechanical release test unit for ground testing of static load and release function.

Technology Overview

CONCEPT OF OPERATION: MEDIUM-DUTY HDRMS

In non-pyrotechnic HDRMs, the planned release of the deployable satellite/payload is activated by a pre-determined value of electrical current to a fuse-wire system that causes the wire to break under tension and allows a pre-loaded mechanical bolt to actuate.

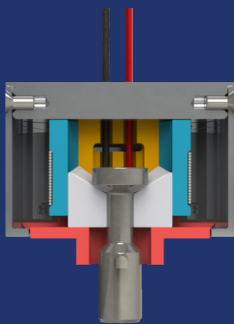

Restrained Condition

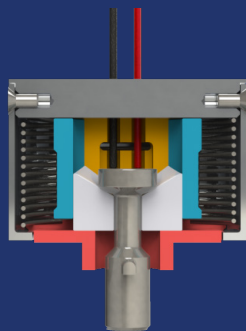

Electrical current applied,
wire breaks under
tension

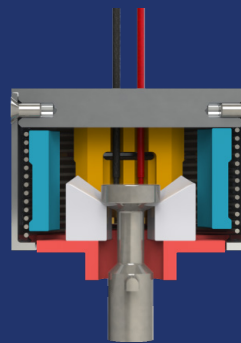

Mechanical bolt begins
actuation

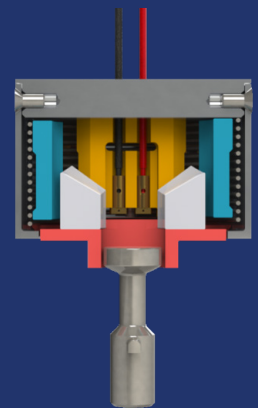

Bolt extracts, releasing
the payload

REFURBISHMENT OF SINGLE-EVENT HDRMS WITH NEW INITIATOR UNITS

Hold-Down and Release Mechanisms are typically subjected to multiple cycles of ground test prior to flight. The refurbishment, or rebuilding, of a single-event HDRM with a replaceable initiator is easily accomplished in the field by trained personnel. In the case of light and medium duty HDRMs, a single set or grub screw is removed and the spent initiator kit is extracted from the device. The technician then re-packs the initiator unit with release bolt and wedge pieces, and the entire subassembly is inserted into the HDRM housing to be fixed in place once again with the set screw. Heavier-duty HDRMs use four top-of-unit fasteners in place of the single set screw.

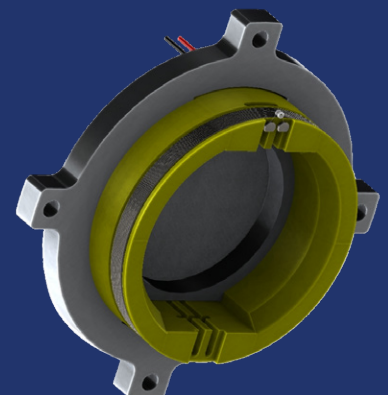
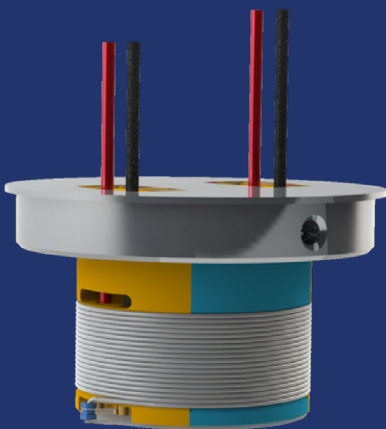



SPACE-GRADE - TRL 9

Release and Separation Interconnect Mechanisms

- HOLD-DOWN AND RELEASE MECHANISMS (HDRM)
- BLIND-MATE / ASF / LANYARD-RELEASE CONNECTORS

OCTOBER 2025

SuperNine[®]

BLIND-MATE ASF

Blind-mate, float-mount, assisted release connectors, adjustable separation force and misalignment feature

Titan rocket launch from Vandenberg AFB
Photo: 30th Space Wing



Available feed-thru configurations

Blind-mate, fixed, and float-mount interconnects for launch, satellite, and payload deployment applications

- Available in most symmetrical MIL-STD-1560 and high-speed insert arrangements with contacts sizes from #23 to #8
- Select designs offered with user-configurable assisted separation force (ASF) feature
- NASA outgassing bake-out process available
- Designed to withstand the rigors of launch and flight—including shock, vibration, thermal vacuum, acceleration, and temperature extremes
- Crimp-removable contacts standard. PC tails, dual-flange standoffs, hermetically sealed, and custom blind-mate configurations available



Dead-Face connectors for isolation and disconnection of electrical signals prior to connector separation.

Glenair Series 253 blind-mate connectors with assisted separation force are used for interconnection and deployment of satellites, scientific payloads, interstage applications and more. This versatile family of highly engineered and environmentally sealed connectors is also appropriate for use in missile umbilical and weapons release.

SPACE-GRADE BLIND MATE SuperNine float-mount and adjustable separation force connectors

GLENAIR
QwikConnect

IAW MIL-DTL-38999, environmental, crimp contact

CRITICAL MECHANICAL FEATURES OF BLIND-MATE AND ADJUSTABLE SEPARATION FORCE (ZEF) CONNECTORS



Roll-off nose: allows for the smooth disconnection of blind mate plugs and receptacles.

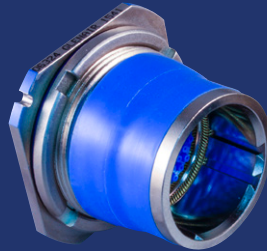

Float mounting: allows for coplanar movement of the receptacle during mating, preventing contact and shell damage.



Misalignment accommodation: Radial, axial, and angular misalignment during mating is accounted for with integral wave springs.

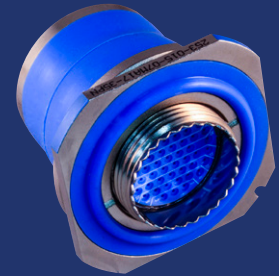

Sealing: Misalignment accommodation makes environmental sealing difficult. The problem is solved with auxiliary external seals.

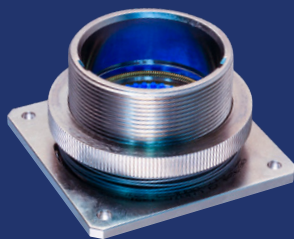

EMI shielding: Glenair incorporates ground springs in receptacle connectors and grounding fingers in special coupling nut-equipped plugs to optimize 360° shell-to-shell continuity.

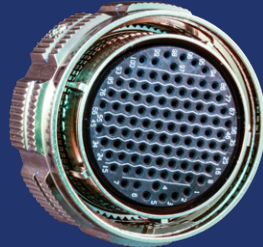

Assisted separation force: Adjustable kick-off style with spring-loaded posts and an adjustment ring to overcome contact retention (normal force).

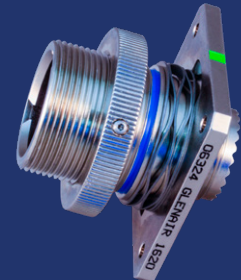

AVAILABLE HERMETIC SEAL AND BULKHEAD FEED-THRU CONFIGURATIONS

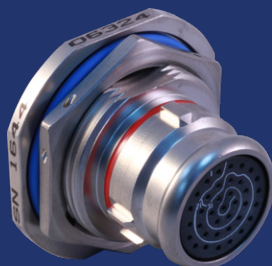

Hermetic Receptacle,
Fixed Jam-Nut Mount,
Roll-On / Roll-Off Nose

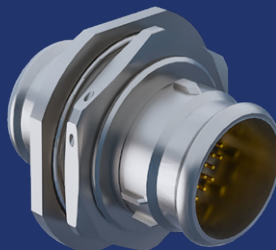

Hermetic Bulkhead Feedthru,
Plug, Fixed-Mount,
Roll-On / Roll-Off Nose

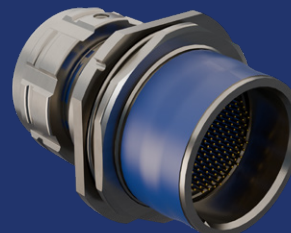

Bulkhead Feed-Thru,
Jam-Nut Float-Mount Receptacle
to D38999 type

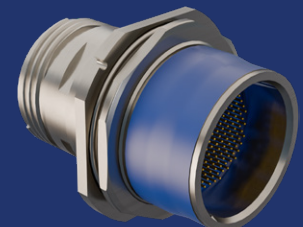

Crimp Feed-Thru,
Jam-Nut Receptacle to
D38999 type



BLIND-MATE ASF

SPACE-GRADE MIL-DTL-38999 SERIES III SuperNine[®] Blind-Mate / ASF Connectors

Technology overview

BLIND-MATE AND ASSISTED SEPARATION FORCE CONNECTORS FOR SPACE FLIGHT APPLICATIONS

Glenair blind-mate assisted separation force connectors are engineered for mission-critical in-flight electrical disconnect applications, including satellite deployment, spacecraft stage separation, missile staging, and umbilical release. These connector pairs deliver precisely tuned assisted separation characteristics—with fully-configurable degrees of force—eliminating the need for lanyard-based actuation technologies.

Each connector assembly is built around either standard MIL-DTL-38999 insert arrangements (MIL-STD-1560 power and signal) or high-speed insert arrangements for shielded data and RF contacts. To ensure smooth and reliable operation, mated connector pairs are calibrated at the factory to account for mating friction and pin / socket normal force retention. A floating shell design prevents mechanical jamming during mating or separation, even under misaligned conditions. The system accommodates both linear and angular misalignment, enabling full blind-mating capabilities. All assemblies are compatible with standard environmental backshells and can be delivered as part of a turnkey separation package. We also offer integration with Glenair non-pyrotechnic Hold Down and Release Mechanisms (HDRMs), as well as turnkey cable harnessing.

LOCKING CIRCUIT TEST-MATE CONNECTOR



Available physical and electrical interlock solution prevents inadvertent armed or enabled state of critical control circuits. Typically mates with fixed-mount chassis or bus interconnect, often as part of a pre-flight safety chain.

BACKSHELLS AND ACCESSORIES FOR SUPERNINE BLIND-MATE CONNECTORS

ADAPTER CODE **F**

"F" adapter code accessories (D38999 Series I, imperial thread) fit this connector

ADAPTER CODE **H**

"H" adapter code accessories (D38999 Series III, metric thread) fit this connector



Glenair blind-mate, assisted separation force, and dead-face connectors may be equipped with protective covers, shield termination backshells, saddle clamps, and other front-end and back-end connector accessories with identical space-grade plating. Special "SplayMaster" backshells are supplied for use with high-speed data / RF series connectors. How-to-Order pages for each connector type indicate the appropriate adapter code to ensure correct accessory thread fit and function. "F" adapter code backshells are compatible with interconnects with MIL-DTL-38999 Series I and II imperial accessory threads. "H" adapter code backshells are compatible with MIL-DTL-38999 Series III and IV metric accessory threads. See Glenair Circular Connector Backshells and Accessories catalog for "F" and "H" order information.

ALSO AVAILABLE: HIGH-SPEED DATA AND RF INSERT ARRANGEMENTS

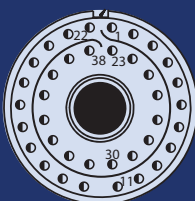

Hybrid high-speed Ethernet plus signalling



High-Speed Plug, Fixed Rear Panel-Mount Series, Roll-On / Roll-Off Nose



High-Speed Receptacle, Float-Mount Series, Environmental



High-Speed Plug/Receptacle Series, Adjustable Zero Separation Force

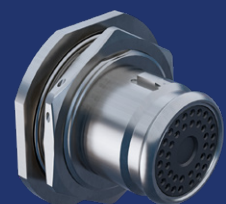

High-Speed Plug, Fixed Rear Panel-Mount Series, Roll-On / Roll-Off Nose

Technology overview

APPLICATIONS



Satellite, spacecraft,
and payload deployment



Stage separation
in spacecraft



Umbilical disconnection in
exoatmospheric launch applications

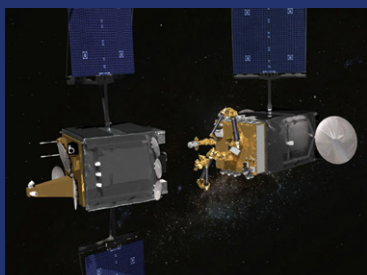

Panel disconnect in cargo pallet
and modular payload deployment

DEAD-FACE IN-FLIGHT SEPARATION CONNECTORS Glenair dead-face (DF) blind-mate connectors are designed for critical in-flight separation tasks in spacecraft, satellite systems, and missile staging. These connectors feature built-in electrical isolation that occurs prior to mechanical disconnection—enhancing system safety and electrical integrity during separation events.

Design and Operation Glenair dead-face DF connector systems utilize MIL-DTL-38999-qualified insert patterns and standard AS39029 contacts. A key feature of the design is the internal isolation shuttle, which disengages signal paths ahead of the physical break at the separation plane. This design ensures that electrical interfaces remain protected from transients or shorts during and after separation, even in extreme environments. Each connector pair is calibrated during manufacturing to offset normal retention forces such as pin engagement, ensuring consistent and reliable separation performance. The connectors include a floating shell to prevent binding under load or misalignment. Rear-mount installation options simplify integration into panels or structures. The rear interface of the DF connector is compatible with standard MIL-DTL-38999 backshell accessories.

FIXED-MOUNT VS. FLOAT-MOUNT Glenair Blind-Mate interconnects are supplied in two mounting configurations: fixed-mount and float-mount. Both designs incorporate roll-on, roll-off plug nose architectures for reliable mating of connectors in blind-mate (rack-and-panel type) applications. Both styles are rear-mountable for ease-of-installation and termination. Float mount designs offer superior accommodation of connector misalignment in radial (axial), angular (tilt), and longitudinal (depth) orientations. In practical application, fixed-mount (Side A) connectors are typically installed on the chassis bus or frame for stability, while float mount designs with misalignment accommodation (Side B) are commonly installed on the removable payload tray or door.

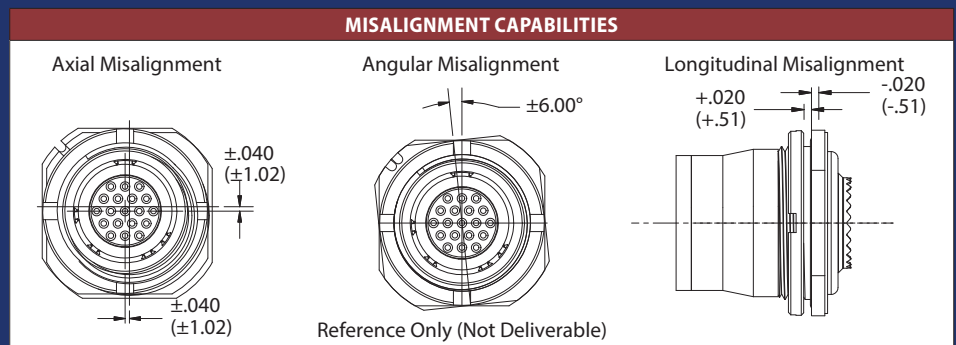

CONNECTOR CLASSES Glenair blind-mate and assisted separation force interconnects are available in the broadest range of connector classes in the industry including crimp, PC-tail, hermetic, float-mount, fixed-mount, dead face, bulkhead feed-thru, high-speed data / RF, and standard power/signal. Special environmental sealing is available for float-mount configurations. Selected part numbers may be supplied with integrated shield termination band porches for optimal SWaP. How to Order pages provide information on mating connectors and available insert arrangements. Consult the factory for custom configurations.



SPACE-GRADE - TRL 9

Release and Separation Interconnect Mechanisms

- HOLD-DOWN AND RELEASE MECHANISMS (HDRM)
- BLIND-MATE / ASF / LANYARD-RELEASE CONNECTORS

OCTOBER 2025

SAE-AS81703 Series 3 and MIL-DTL-38999 Series III type lanyard-equipped fail-safe quick-release connectors



Ideal for high shock / high vibration environments including outer space and defense applications such as missile and payload deployment, Glenair lanyard-release interconnects provide fail-safe, quick-disconnect operation. Supplied in standard density (AS81703 Series 3 type) and high density (MIL-DTL-38999 type) configurations, each connector series is intermateable and intermountable with currently available mil-spec and commercial connectors, and offers enhancements to standard designs. Both the standard-density series and the high-density series are available with an integrated band porch for shield

termination, 360° saw teeth for rear-end accessory clocking, and a red full-mate indicator stripe. The

AS81703 Series 3 type connector is ideally suited for droppable stores, umbilical connections, rocket launch, and other extreme vibration and shock environments where rugged and reliable blind mating and lanyard-release disconnection is a must. The D38999 Series III type interconnect is designed for applications that require high-density and combo insert arrangements IAW MIL-STD-1560.



- Intermateable and intermountable with industry-standard connectors
- Available integrated band porch for easy shield termination
- 360° saw teeth for accessory clocking
- Red full-mate indicator stripe
- Fail-safe instant-disconnect axial-pull lanyard coupling
- Blind mate and rack-and-panel capabilities
- Polarization keying for mis-mate prevention

SAE-AS81703 AND SUPERNINE D38999 SR. III TYPE Lanyard-Release Fail-Safe Connectors

GLENAIR
QwikConnect

Standard-density and high-density solutions

HIGH-DENSITY SUPERNINE SERIES III LANYARD-RELEASE IAW MIL-DTL-38999 AND MIL-STD-1560



Lanyard-release plug with adapter code H accessory thread interface



Lanyard-release plug with integrated cable shield banding platform



Broad range of insert arrangements IAW MIL-STD-1560

STANDARD-DENSITY SAE-AS81703 SERIES



Integrated banding porch for easy shield termination



360° saw teeth on plug and receptacle back ends for fully-configurable accessory clocking

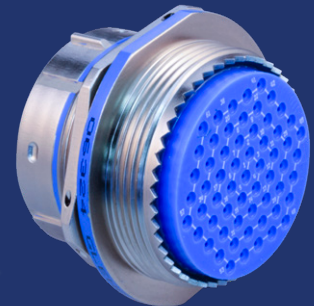

Rack-and-panel mating configuration



Full complement of high-availability backshells and connector accessories

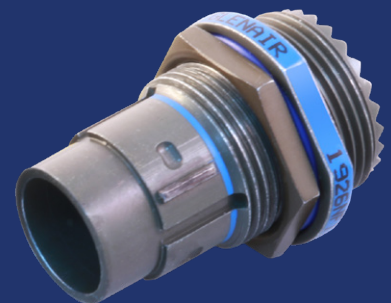

Industry-standard intermateable / intermountable designs

SAE-AS81703 / SUPERNINE D38999 SERIES III TYPE Lanyard-Release Fail-Safe Connectors

Technology Overview: Lanyard-release fail-safe connectors



Launch vehicle telemetry, command, and environmental control



Launch pad ground support equipment

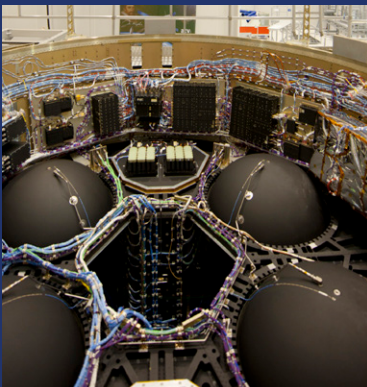

Rack-and-panel applications such as flight control avionics

SAE-AS 81703 SERIES 3 FUNCTIONAL DESCRIPTION AND OPERATION

The AS81703 push-pull, lanyard-release connectors are circular, blind-mate capable connectors designed for high-reliability, rapid-mate/demate cycles. The connector features a spring-loaded locking sleeve engaged upon insertion. A pull on the attached lanyard sleeve disengages the lock, enabling rapid, tool-less disconnection. This is critical for emergency egress or liftoff, where rapid umbilical release is mandatory.

MIL-DTL-38999 TYPE LANYARD-RELEASE FAIL-SAFE INTERCONNECTS

In contrast to the legacy AS81703 series, Glenair lanyard-release interconnects built to MIL-DTL-38999 Series III specifications with MIL-STD-1560 and high-speed contact arrangements offer enhanced performance characteristics tailored for modern spaceflight applications. While both systems utilize lanyard-actuated quick-disconnect mechanisms, the D38999 Series III architecture supports higher contact density, enabling significant reductions in weight and panel footprint—critical for satellite buses, upper stages, and reusable launch vehicles. The connector series' utilization of MIL-STD-1560 insert patterns simplifies integration across diverse subsystems and facilitates interconnect system design and installation. Additionally, these D38999 Series III type connectors offer improved EMI shielding, superior contact retention under shock and vibration, and the ability to accommodate high-speed data and shielded RF insert arrangements. Breakaway plug designs are available with an integrated cable shield band porch, further reducing package size and weight. Rugged triple-start stub ACME coupling offers outstanding performance in high vibration and shock applications. These advantages, combined with an improved release mechanism with faster, more reliable separation, make the MIL-DTL-38999-based quick-disconnect solutions a technically superior and forward-compatible replacement for AS81703 connectors in current-generation space and launch platforms.

SPACE APPLICATIONS AND DEPLOYMENT

Both series of lanyard-release umbilical connectors have been deployed in Launch Vehicle applications, serving as electrical interfaces between ground systems and the vehicle for power, telemetry, command, and environmental control prior to launch. These connectors facilitate quick disconnect at liftoff while maintaining signal integrity during extended pre-launch operations. Other applications include:

Ground Support Equipment (GSE): Integrated into umbilical towers, service platforms, and mobile servicing equipment, enabling rapid connection/disconnection during vehicle processing.

Payload Integration and Checkout: Used for temporary connections to satellite or spacecraft payloads during pre-launch functional testing.

Environmental Control Systems: Connecting fluid sensors, valves, and electrical control lines delivering conditioned air or purge gases.

Across the board, the blind-mate capability and reliable release designs of both series make them well-suited for constrained pad environments where operators may have limited visibility or access and where rapid planned disconnect is mandatory.

SUPERNINE D38999 SERIES III TYPE Lanyard-Release Fail-Safe Connectors

Technology Overview: SuperNine Series III fail-safe lanyard release connectors

TECHNICAL FEATURES

- Commercial equivalents of D38999/31 Types 1, 4, and 6; and D38999/29 and /30
- Connectors are supplied with contacts including spares
- Blue color band indicates rear-release retention system
- Mates with any QPL manufacturer's MIL-DTL-38999 Series III receptacle connector having the same shell size, insert arrangement, and polarization
- Available with accessory threads, integrated banding porch, shrink boot adapter
- Summary of Connector types:
 - Type 1 long shell
 - Type 4 standard (short) shell
 - Type 6 medium-length shell



233-216 IAW D38999/31
Note forward location of coupling nut, and rearward position of lanyard release ring.

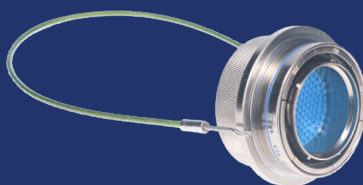

233-223 IAW D38999/29 and /30
Note rearward location of coupling nut, and forward position of lanyard release ring.

SUPERNINE SERIES III FAIL-SAFE LANYARD-RELEASE FUNCTIONALITY

Glenair SuperNine Series III Type 1, 4, and 6 lanyard-release breakaway plugs are special variants of the popular triple-start threaded circular connector, designed for rapid disconnect applications. Originally developed for droppable stores, aircraft ejection seats, fuel tank quick-disconnects, missile pods, and other military applications, the series is also suited for use in space vehicle launch, stage separation, and payload deployment. These connectors are engineered to separate quickly and cleanly without requiring rotation, when mated to standard threaded receptacles.

MECHANICAL ACTION OVERVIEW:

The breakaway plug has an integral coupling and breakaway mechanism that bypasses the normal threaded un-mating action of standard Series III connectors. Here's how the release works:

1. Threaded Coupling, But with a Twist

Plugs are fully threaded and mated with standard D38999 Series III receptacles using ACME-style stub threads (per MIL-DTL-38999 Series III). These threads are robust and resistant to vibration and shock decoupling.

In the breakaway design, the plug's coupling mechanism is engineered to override the thread engagement when axial force is applied, rather than requiring the typical rotational back-off.

2. Spring-Loaded and Friction-Limited Coupling Nut

The threads on the plug are divided into concentric sections which are pushed outward by spring-force upon retraction of the lanyard-equipped outer sleeve, thus releasing their hold on the mating receptacle.

3. Retention Ring Location and Function

233-216 series connectors IAW D38999/31 position the retention ring and lanyard release attachment in a rearward (aft) position on the connector for optimal speed of release and deployment. 233-223 series connectors IAW D38999/29 and /30 position the retention ring and lanyard release attachment in a more forward location providing easier access to the knurled connector coupler. Both designs provide rapid, reliable, fail-safe demating.



Retraction of the lanyard sleeve allows the threaded coupler—split into six sections—to rapidly expand and release.

SUMMARY OF KEY DESIGN FEATURES

FEATURE	FUNCTION
Threaded coupling nut	Mates like a normal Series III connector
Release mechanism	Allows axial breakaway without rotation
Receptacle compatibility	Compatible with standard threaded receptacles
Lanyard actuation	Triggers fail-safe release, with calibrated preset force
Connector length	Short, medium, and long packaging for different bulkhead thicknesses



SPACE-GRADE - TRL 9

Release and Separation Interconnect Mechanisms

- HOLD-DOWN AND RELEASE MECHANISMS (HDRM)
- BLIND-MATE / ASF / LANYARD-RELEASE CONNECTORS

OCTOBER 2025

HIGHFLEX™

GROUNDING CONDUCTORS

Flexible braided straps for EMI noise suppression and equipotential bonding

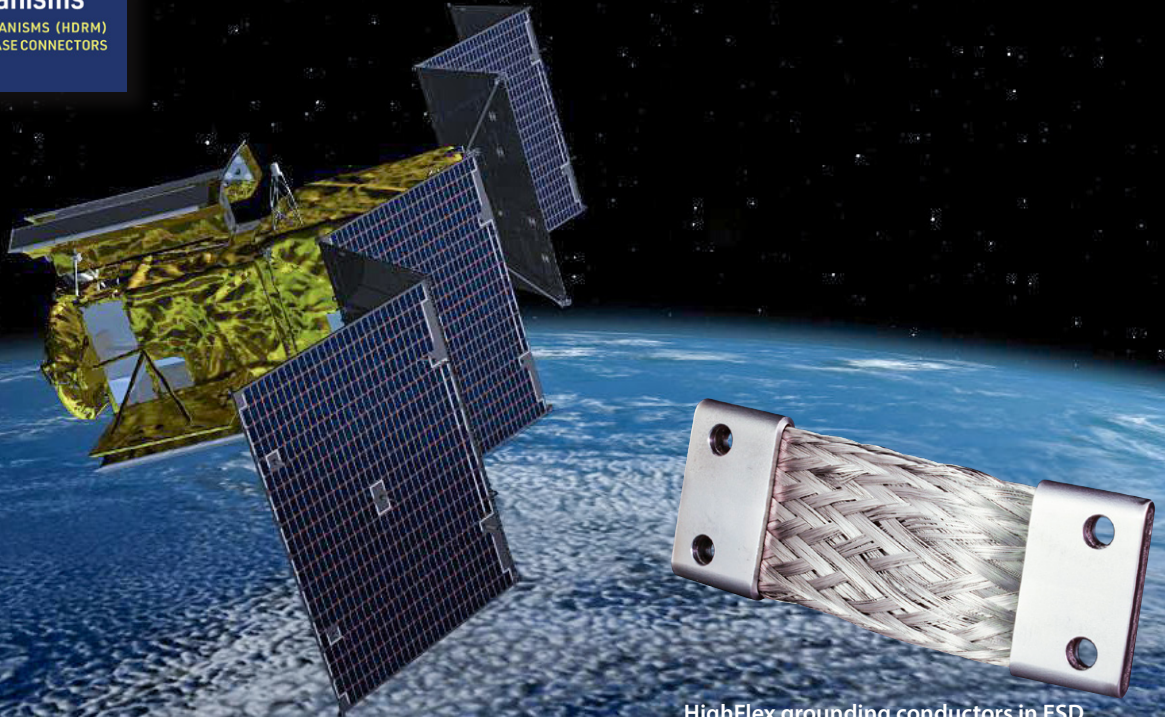

HighFlex grounding conductors in ESD bonding applications perform best in short, wide form-factors

Flexible, durable ArmorLite ESD bond straps are supplied in microfilament materials optimized for the moderate current and resistance requirements of electrical potential bonding in space applications. ArmorLite 100% offers superior flexibility and ductility. ArmorLite CF is a special construction designed for improved corrosion protection. ArmorLite Ag silver-plated microfilament SST braid offers the lowest electrical resistance. NASA-STD-4005 and ECSS-E-ST-20-07 compliant.

- Durable, low-resistance ground straps with highly conductive or dissipative performance
- High-flexibility, low-resistance bond straps for ESD dissipation
- Glenair signature and comparable industry-standard designs
- Special heat-dissipation custom configuration flexible braided straps
- Microfilament materials with superior mechanical performance, flexibility, and windowing resistance compared to NiCu A-A-59569/QQB575
- Proven performance in space: TRL9

Technology overview

HIGHFLEX GROUNDING CONDUCTORS FOR SPACE FLIGHT EARTHING AND BONDING APPLICATIONS

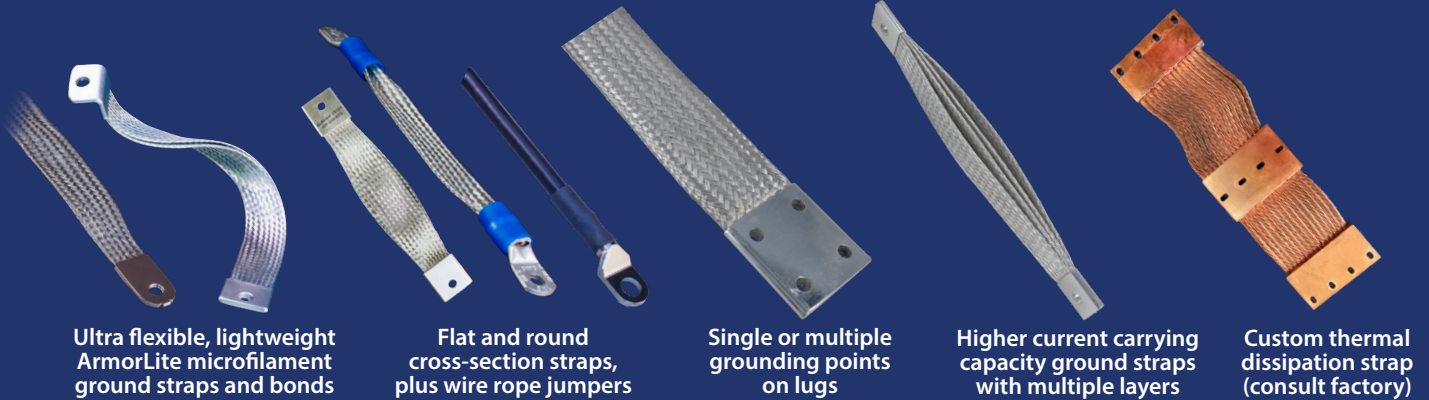

Ultra flexible, lightweight ArmorLite microfilament ground straps and bonds

Flat and round cross-section straps, plus wire rope jumpers

Single or multiple grounding points on lugs

Higher current carrying capacity ground straps with multiple layers

Custom thermal dissipation strap (consult factory)

APPLICATIONS



Hinged solar panel bonding



Chassis-to-payload grounding

Function in Spacecraft Systems

1. Electrical Grounding

- Provide a low-impedance return path for electrical current, particularly in power systems (e.g., batteries, power buses).
- Maintain electrical continuity across mechanically separated parts, such as between a solar panel and the spacecraft body.
- Absorb vibration and thermal cycling stresses due to their flexible, fatigue-resistant design.

2. Electrostatic Bonding

- Maintain equipotential bonding between surfaces and structures to prevent differential charging, which can lead to damaging ESD arcs.
- Ensure that exposed surfaces (e.g., solar arrays, radiators) are kept at the same electrical potential as the main spacecraft chassis.

Compliance with Space Standards

- NASA-STD-4005 specifies that all conductive surfaces in a LEO spacecraft must be bonded to chassis ground with less than 2.5 milliohms resistance. Glenair straps meet or exceed this requirement with reliable, gas-tight connections and rugged construction.
- ECSS-E-ST-20-07 calls for equipotential bonding networks to mitigate surface and internal charging risks. Glenair's ESD straps offer flexible, conductive connections that remain effective even across deployable structures like articulated solar arrays or sensor booms.

Typical Applications in Spacecraft

- Solar Panel Deployment Mechanisms: Used to maintain electrical continuity across hinges and rotating joints that would otherwise be electrically isolated.
- Battery and Power Distribution Modules: Provide grounding between the battery frame and spacecraft bus, allowing safe discharge of fault currents and suppressing EMI.
- Payload Instruments: Prevent differential potentials across instrument chassis and mounting points, reducing noise and risk of ESD damage.
- Thermal Radiators and Exterior Panels: Keep isolated or painted surfaces bonded to spacecraft ground to avoid surface charging.



Glenair Signature Launch Vehicle and Spacecraft Constellation Interconnects

MISSION-CRITICAL TECHNOLOGY

Connectors, cables, and wiring play crucial roles in the functionality of launch vehicles and satellite constellations in communication systems, power distribution, data transmission, guidance and control.

Electrical Power Distribution

Power interconnects distribute electrical power from the primary power source (e.g. batteries, fuel cells) to various subsystems, components, and payloads on board the launch vehicle, including propulsion systems, avionics sensors, communication equipment, and other electrical devices throughout the rocket.

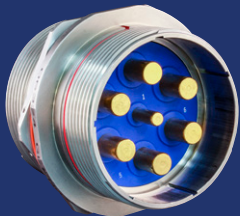

High-voltage power bulkhead feed-thru



HiPer-D® composites with hybrid signal and power



PowerPlay™ high-power in MIL-DTL-38999 Series III packaging

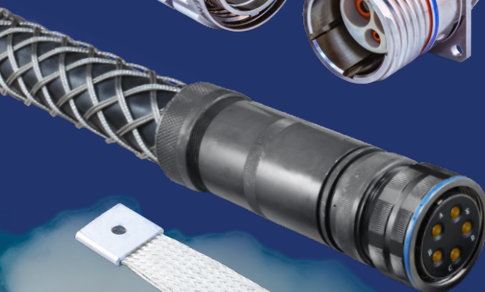

PowerTrip® high-current, low-resistance ground power interconnects

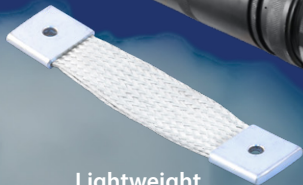

Lightweight ESD bonds and high-conductivity ground straps



TurboFlex™ ultra-flexible power distribution cable



High-Speed Optical / Electrical Data Transmission

High-speed interconnects are used to transmit data in applications where low latency and high bandwidth are critical—such as between on-board computers, sensors, and data processing units.

MT Ferrule high-density fiber optic connectors

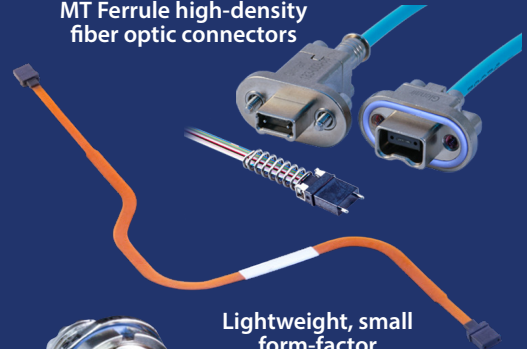

Lightweight, small form-factor Optical Flex jumpers



Mighty Mouse micro miniature fiber optic interconnects



VITA 66.1 and 66.4 optical backplane connectors



El Ocho™ high-speed octaxial for 10GbE



VersaLink™ 28 Gb/s differential twinax



GMMD modular high-speed Micro-D RF / 10GbE connector

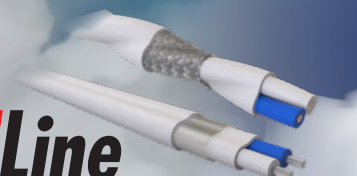

Space-Grade Harness Assemblies

Turnkey digital data, high-speed Ethernet, power, and RF assemblies for satellite bus and payload interconnection—cleanroom assembly, comprehensive qualification testing.

Electromechanical Actuation

Hold-Down and Release Mechanisms, and other electromechanical devices used in satellite, solar panel, and antenna deployment.

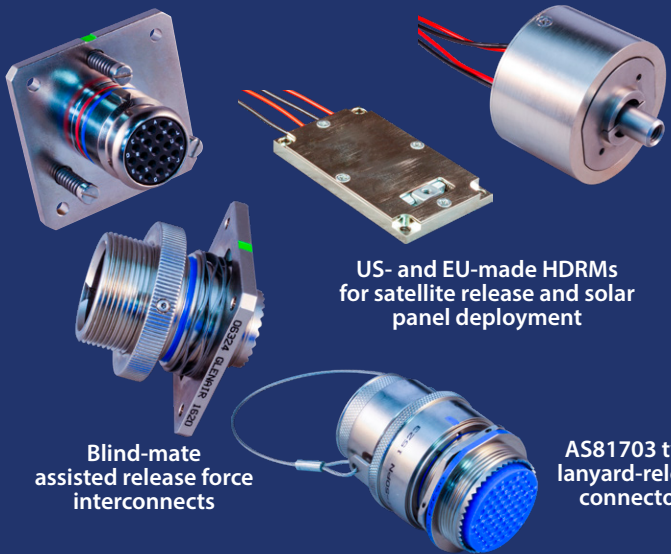

US- and EU-made HDRMs for satellite release and solar panel deployment

Blind-mate assisted release force interconnects

AS81703 type lanyard-release connectors

Low-Speed Digital Data Bus Transmission

Electrical signal interconnects carry low-speed databus control signals, telemetry data, and other command and communications on and about satellite systems.



Glass and Encapsulant Hermetic Seal Connectors

Rectangular form-factor interconnects: Micro-D, Series 79

Series 806 Mil-Aero Micro Miniature D38999

RF (Radio Frequency) Interconnection

RF interconnects are used for wireless communication, telemetry, tracking, and command operations between the satellite and mission control.

RF I/O-to-board ganged cable assemblies with Glenair Signature connectors, contacts, and cable

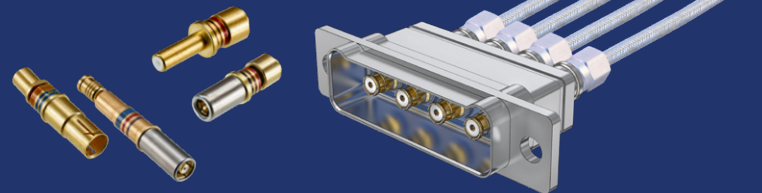

Size #8, #12, and #16 coaxial and concentric twinax contacts for multi-pin aerospace-grade connectors

G-Link^{RF}



26.5 GHz G-Link RF contacts with integral female SMA adapter for easy cable attachment



Series 806 RF multipin circular

Series 795RF multipin rectangular

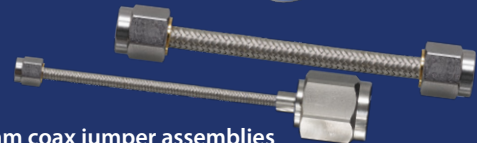
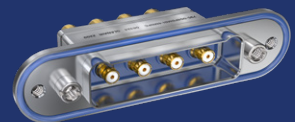

50 Ohm coax jumper assemblies with low-loss cable and precision-grade connectors

ThermaRexTM

CRYOGENIC • HIGH-TEMPERATURE



Turnkey crimp-contact cryogenic cable harnesses for low thermal conductivity payloads

ThermaRex Cryo for -195°C to +260°C temperature resistance

MIL•STAR
HIGH-PERFORMANCE HOOKUP WIRE AND CABLE

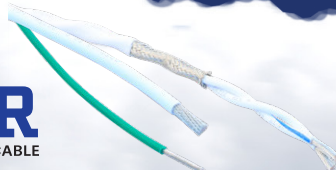

BLUMARK RF
COAX CABLES



Outlook

The Middle of the Road

In 1917, Dr. June McCarroll, a California physician, was nearly run off the road by a truck while driving her Model T Ford. The stretch of highway she was on had no lane markings, and authorities paid little attention to her concerns about the road's poor safety record. Frustrated but undeterred, she took matters into her own hands: she painted a white line down the center of the road along a bad two-mile stretch just outside of Indio, California.

The good doctor did not stop there. She campaigned tirelessly for years for improved road safety, and in 1924 California made painted centerlines mandatory—a safety measure that would spread across the country and save countless lives. Today, a stretch of Interstate 10 is named the *Doctor June McCarroll Memorial Freeway* in her honor.

I find this story to be a perfect example of how some problems only get solved by making the matter visible, by pushing the issue at hand right out there into the middle of the road.

In our Glenair factory, we have, on occasion, run into process problems that resisted being solved. Operational problems that the team may have attacked by writing new work instructions, changing our approach to job scheduling, or even authoring reports for upper management.

A perfect example, one that all factories deal with, is late orders. Now the conventional approach is to go down the Resource Planning Database route with a team of implementers who spend their day reviewing workflow on portable laptops. I think most of you know that is not how we roll.

No, our call was to put the actual, physical jobs, complete with their bins of constituent parts, Bills of Material, and color-coded job cards out on a late-job table smack-dab in the middle of the factory floor where EVERYONE could see them. And let me tell you, did things ever get handled quickly when the entire team could see what needed to be done with their own eyes.

Now I'm not saying you can't attack business problems the conventional way: by adding more checks and balances, tightening shop-floor procedures, posting weekly reminders in the lunchroom, and so on. But for our money, what really works is far simpler: you make the problem **visible**.

If a single missing component is holding up an entire build, that absence needs to be made obvious to everyone in the loop—not hidden away on a laptop. As our business continues to grow, this same approach will matter more, not less. People can't respond to what they can't observe. But they will step up and take action if critical work is laid out for all eyes to see. Just like Dr. McCarroll's centerline-stripe was, down the middle of that road in Indio, California.

Chris Toomey

QwikConnect

GLENAIR • Volume 30 • Number 2

Publisher

Christopher J. Toomey

Managing Editor

Marcus Kaufman

Art Director/Editor

Mike Borgsdorf

Graphic Design and Editing

George Ramirez

Ryan O'Shea

Greg Wiegand

Technical Consultant

Jim Donaldson

Issue Contributors

Deniz Armani

Josh Castrey

Raul Galvan

Mike Ghara

Guido Hunziker

Sam Peeling

Matt Shingleton

Jose Silva

Ali Yassine

Distribution

Terry White

To subscribe or unsubscribe,

please contact Terry White:

twhite@glenair.com

QwikConnect is published quarterly by Glenair, Inc. and printed in the U.S.A. All rights reserved. © Copyright 2026 Glenair, Inc. A complete archive of past issues of QwikConnect is available on the Internet at www.glenair.com/qwikconnect

GLENAIR, INC.

1211 AIR WAY
GLENDALE, CA 91201-2497

TEL: 818-247-6000

FAX: 818-500-9912

E-MAIL: sales@glenair.com

www.glenair.com

