

D-Subminiature

289-003, 289-004, 289-019

Protective Cover

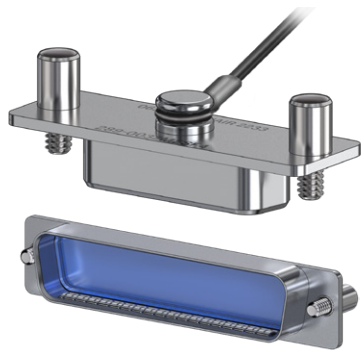

289-003, 289-004, 289-019

This accessory fits D-Subminiature M24308 and Series 28 HiPer-D connectors.

Protective cover fits Glenair Series 28 HiPer-D connectors and MIL-DTL-24308 connectors. Socket connector cover fits over connector shell and has fluorosilicone gasket. Pin connector cover fits inside connector shell. Socket connector cover has optional ground springs for EMI protection. Attach to panel with optional lanyard. Aluminum or stainless steel. Stainless steel screwlocks. Socket cover has nickel-plated copper alloy ground springs and fluorosilicone gasket.

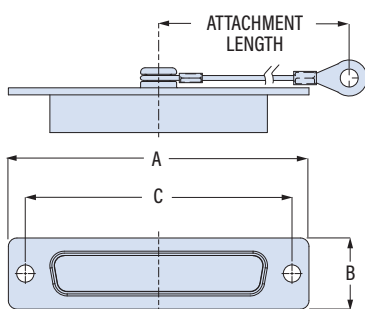

Shell Size	A		B		C	
	±.015 (0.38) in	mm	±.015 (0.38) in	mm	in	mm
1	1.213	30.8	.494	12.6	.984	25.0
2	1.541	39.1	.494	12.6	1.312	33.3
3	2.088	53.0	.494	12.6	1.852	47.0
4	2.729	69.3	.494	12.6	2.500	63.5
5	2.635	66.9	.605	15.4	2.406	61.1
6	2.729	69.3	.668	17.0	2.500	63.5

PART NUMBER

Sample PN → **289-003 ME 3 S F 4 -06**

Base P/N	289-003	Cover, Pin Connector	
	289-004	Cover, Socket Connector, with Ground Springs	
	289-019	Cover, Socket Connector, No Ground Springs	
Shell Size	1 2 3 4 5 6		
Material / Finish	TZ	Tin-Zinc	
	MN	MegaNickel	
	ME	Aluminum/Electroless Nickel	
	NF	Aluminum/Olive Drab Cadmium	
	MT	Aluminum/Nickel-PTFE	
	ZR	Aluminum/Black Zinc-Nickel	
	ZI	SST/Passivated	
Screwlocks	N	No Screwlocks (.120 (3.0) dia. thru-holes)	
	S	Socket Head Male Screwlocks	
	P	Female Screwlocks (fixed, non-rotating)	
Attachment Type	N	No Attachment	
	F	Wire Rope, Black Nylon Jacket	
	H	Wire Rope, Black FEP Jacket	
Attachment Length	Omit for Attachment Type N Length in One Inch Increments (Example: "5" for five inches)		
Attachment Diameter	Omit for Attachment Type N		
	Code	Screw Size	Ring ID
	Omit	#4	.126 (3.2)
	-06	#6	.145 (3.7)
	-08	#8	.187 (4.7)
-10	#10	.197 (5.0)	

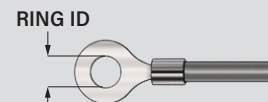

TABLE 1
SCREWLOCK OPTIONS

S	P
4-40 SST Socket Head Male Screwlocks and Retainers	4-40 SST Female Screwlocks, Nuts, and Lockwashers

TABLE 2
ATTACHMENT TYPE

F	
	Wire Rope, Black Nylon Jacket 6/6 nylon over stainless steel rope, .034 (0.9) diameter, good flexibility, good abrasion resistance, -55 to +100 °C
H	
	Wire Rope, Black FEP Jacket Black FEP jacket over SST rope, good flexibility, good abrasion resistance, .034" diameter, -65 to +200 °C