

527-070

Backshell, EMI TAG Ring, DPX2

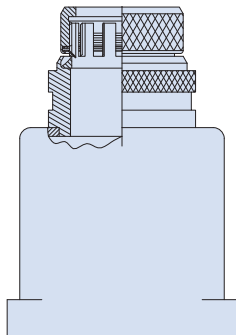

527-070

EMI TAG Ring® backshell fits DPX2 connectors

Fits ITT Cannon DPX2 connectors. Backshell has slotted ring, gold-plated ground spring and Teflon friction washer for terminating individual wire shields. Two strain relief options: saddle clamp or nut (*nut requires shrink boot for cable strain relief*).

Aluminum with stainless steel hardware. Gold-plated beryllium copper ground spring, Teflon friction washer.

TAG® RING

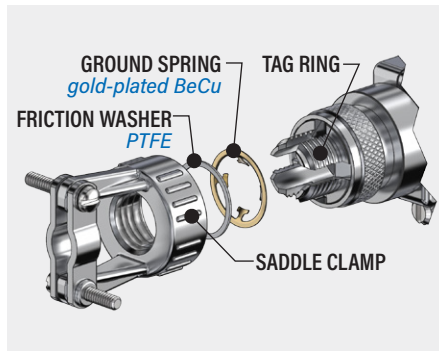

SHRINK BOOT

Optional lipped heatshrink boot fits .135 (3.4) wide boot groove. Type 1 high-performance semi-rigid elastomer resists fuels and oils and withstands temperature extremes. Operating temperature range -75 to +150 °C.



Part Number 770-001S108

PART NUMBER

		Sample PN →	527-070	M	L	S	T	
Base P/N	527-070							
Finish	M	Electroless Nickel						
	JF	Cadmium with Yellow Chromate						
	TZ	Tin-Zinc						
	NF	Olive Drab Cadmium						
Strain Relief	Omit	Nut						
	L	Saddle Clamp						
Entry Location	Omit	Top Entry						
	S	Side Entry						
Shrink Boot	Omit	None						
	T	Shrink Boot Included (770-001S108)						

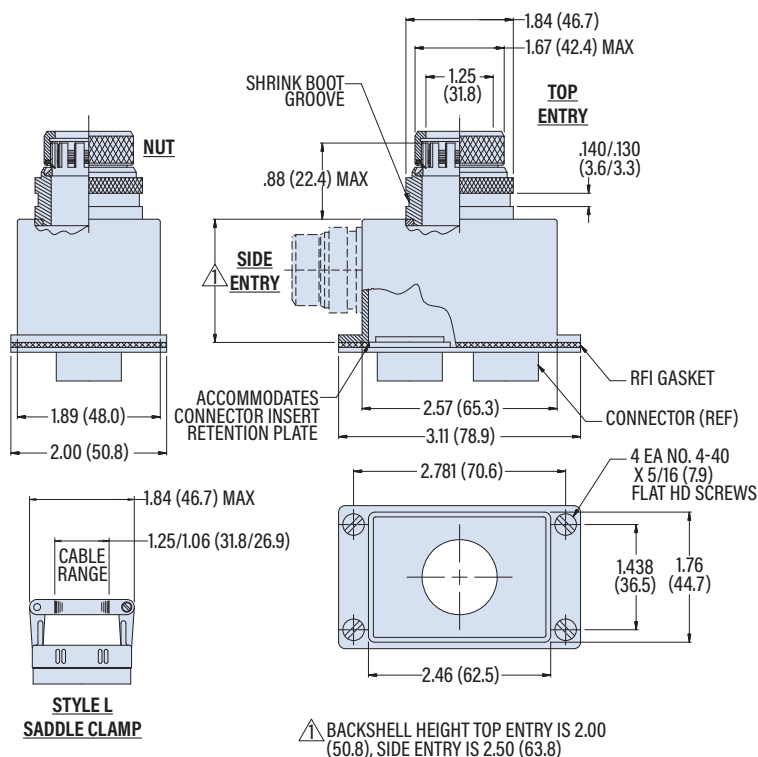

STYLE L SADDLE CLAMP

BACKSHELL HEIGHT TOP ENTRY IS 2.00 (50.8), SIDE ENTRY IS 2.50 (63.8)